

Anybus Communicator CAN - CC-Link INSTALLATION SHEET



HMS Industrial Networks AB
Web: www.anybus.com
Tel: +46 35 172900
E-mail: info@hms.se



SP1316, rev 2.00, Apr 2012, AB7321

www.anybus.com

Module Front

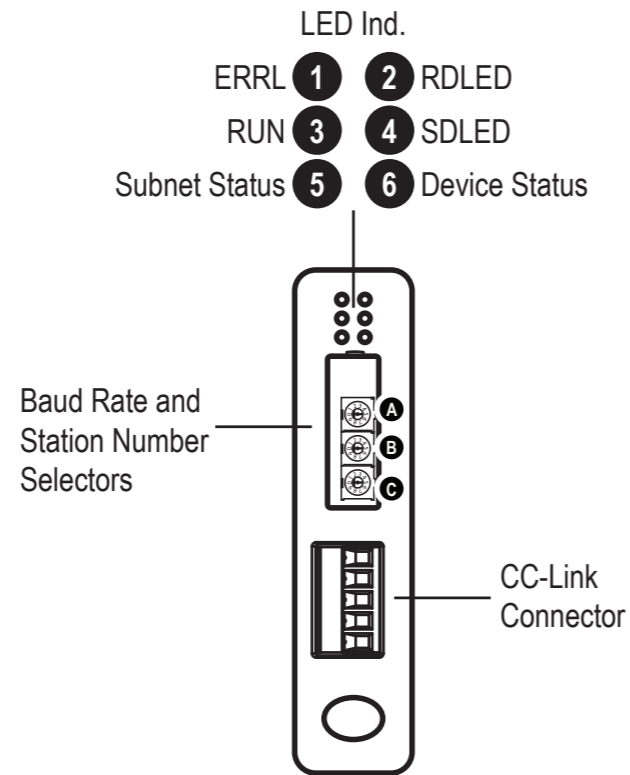

LED Indicators

LED no	Indication	Meaning
1 (ERRL)	Off Red	Power off or normal operation CRC error detected Illegal station number or illegal baud rate selected
2 (RDLED)	Off Green	No data reception or power off Data reception
3 (RUN)	Off Green	Power off, network non-participating or timeout status Normal operation
4 (SDLED)	Off Green	No data transmission or power off Data transmission
5 (CAN Subnet Status)	Off Green Flashing red Red	Power off/no CAN communication Running with no transaction errors/timeout Transaction error/timeout or subnetwork stopped Fatal error
6 (Device Status)	Off Alternating red/green Green Flashing green Red	Power off/initializing Invalid or missing configuration Run Idle Fatal error

Accessories Checklist

The following items are required for installation:

- Anybus Configuration Manager - Communicator CAN (available at www.anybus.com)
- CAN cable (included D-sub can be used)
- USB cable (type B) for configuration download
- CC-Link cable (not included)

Installation and Startup Summary

- Build the configuration in the Anybus Configuration Manager.
- Set the CC-Link switches to the desired values.
- Mount the Communicator at its proper position.
- Connect the USB, CC-Link and CAN cables (if needed, use cables with terminations or add terminations).
- Power up the module and download the configuration.
- Remove the USB cable.

CC-Link Connector

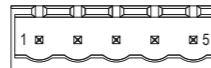

Pin no	Signal	Description
1	DA	Communication signals
2	DB	
3	DG	Digital ground
4	(shield)	Cable shield
5	FE/PE	Frame ground

CC-Link Station Number Selectors

Rotary switch	Meaning
A	Station Number x1
B	Station Number x10

CC-Link Baud Rate Selector

Setting (Rotary Switch C)	Value (bps)
0	156 k
1	625 k
2	2.5 M
3	5 M
4	10 M

Technical Details

- Power supply:
24 V DC (-10% to +10%).
- Power consumption:
Maximum power consumption is 250 mA @ 24 V DC.
Typical power consumption: 100 mA @ 24 V DC.
- Protective Earth (PE):
Internal connection to PE via DIN-rail.
Note: Make sure the DIN-rail is properly connected to PE.

CC-Link Support

Technical questions regarding the CC-Link fieldbus system should be addressed to the CC-Link Partner Association.

Online: www.cc-link.org

For maintenance and support, contact the HMS support department. Contact information is available at the support pages at www.anybus.com.

Further information and documents about this product can be found at the product pages on www.anybus.com.

Bottom View

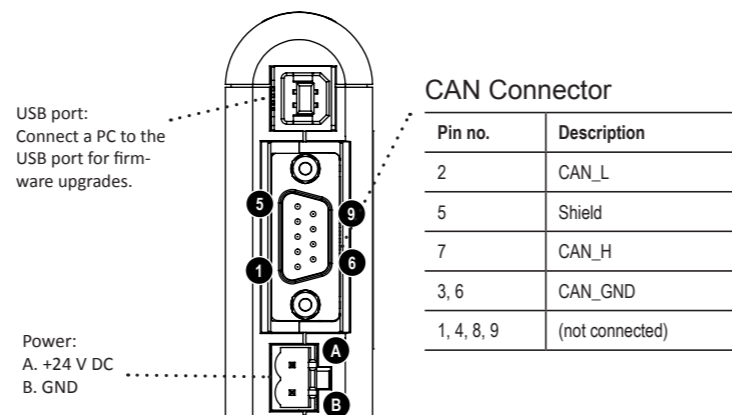

Anybus Communicator CAN INSTALLATION SHEET

DIN-rail Mounting

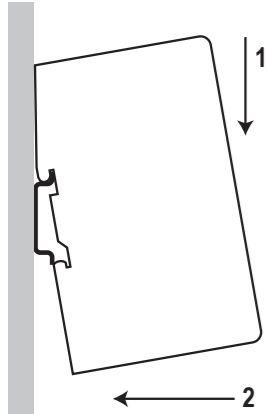

To snap the gateway on, first press it downwards (1) to compress the spring in the DIN-rail mechanism, then push it against the DIN-rail as to make it snap on (2).

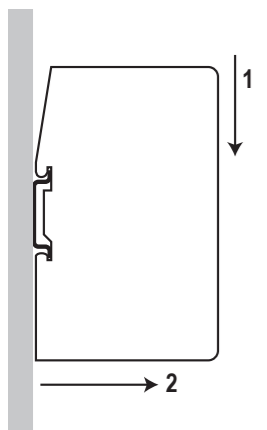

To snap the gateway off, push it downwards (1) and pull it out from the DIN-rail (2), as to make it snap off from the DIN-rail.

Additional Installation and Operating Instructions

Supply voltage: The X-gateway requires a regulated 24 V (21.6 V to 26.4 V) DC power source.

Field wiring terminal markings (wire type (Cu only, 14-30AWG)
"Use 60/75 or 75°C copper (CU) wire only"
Terminal tightening torque (5-7 lb-in (0.5 - 0.8 Nm)).

Use in Overvoltage Category I Pollution Degree 2 Environment.

Install in an enclosure considered representative of the intended use. To comply with ATEX directives, the equipment must be installed within an IP54 enclosure and must be installed with a transient suppressor on the supply that does not exceed 140% (33.6 V DC) of the nominal rated supply voltage.

Operating temperature/Surrounding temperature:
-25 to +55 degrees C @ 250 mA @ 24 V DC.

Maximum surface temperature: 135 degrees C.

Pressure: 850 - 1050 millibar.

This product is designed to safely operate in class I, division 2 Hazardous location according to ANSI/ISA 12.12.01-2011 and category 3, zone 2 according to EN 60079-0, EN 60079-11, and EN 60079-15.

SUITABLE FOR USE IN CLASS I, DIVISION 2, GROUPS A, B, C AND D HAZARDOUS LOCATIONS, OR NONHAZARDOUS LOCATIONS ONLY.

Warnings

- **WARNING - EXPLOSION HAZARD - SUBSTITUTION OF ANY COMPONENTS MAY IMPAIR SUITABILITY FOR CLASS I, DIVISION 2.**
- **WARNING - EXPLOSION HAZARD - WHEN IN HAZARDOUS LOCATIONS, TURN OFF POWER BEFORE REPLACING OR WIRING MODULES.**
- **WARNING - EXPLOSION HAZARD - DO NOT DISCONNECT EQUIPMENT WHILE THE CIRCUIT IS LIVE OR UNLESS THE AREA IS KNOWN TO BE FREE OF IGNITABLE CONCENTRATIONS.**
- **WARNING - EXPLOSION HAZARD - THE USB CONNECTOR IS NOT FOR USE IN HAZARDOUS LOCATIONS AND FOR TEMPORARY CONNECTION ONLY. DO NOT USE, CONNECT OR DISCONNECT UNLESS THE AREA IS KNOWN TO BE NONHAZARDOUS. CONNECTION OR DISCONNECTION IN AN EXPLOSIVE ATMOSPHERE COULD RESULT IN AN EXPLOSION.**
- **WARNING - INSTALL IN AN ENCLOSURE CONSIDERED REPRESENTATIVE OF THE INTENDED USE. TO COMPLY WITH ATEX DIRECTIVES, THE EQUIPMENT MUST BE INSTALLED WITHIN AN IP54 ENCLOSURE AND MUST BE INSTALLED WITH A TRANSIENT SUPPRESSOR ON THE SUPPLY THAT DOES NOT EXCEED 140% (33.6 V DC) OF THE NOMINAL RATED SUPPLY VOLTAGE.**

UL Certification



LISTED 67AM

Atex Certification

EX nA ic IIC T4 Gc



DEMKO 12 ATEX 1062548X

EMC Compliance (CE)



This product is in accordance with the EMC directive 2004/108/EC through conformance with the following standards:

- **EN 61000-6-4 (2007)**
Emission standard for industrial environment
EN 55016-2-3, Class A (2006)
- **EN 61000-6-2 (2005)**
Immunity for industrial environment
EN 61000-4-2 (2009)
EN 61000-4-3 (2006)
EN 61000-4-4 (2004)
EN 61000-4-5 (2005)
EN 61000-4-6 (2007)

Label Markings

Product number

Product name and description

Surrounding air temperature and electrical ratings

Warnings

Product information bar code

Product name and description: Anybus[®] Communicator[™] CAN - XXXXXX

Article#: AB7XXX-X Serial#: SAMPLE

FW: X.XX

MAC-address: XX-XX-XX-XX-XX-XX

CE II 3 G Ex nA ic IIC T4 Gc Demko 12 ATEX 1062548X -25°C ≤ Ta ≤ 55°C

UL LISTED 67AM IND: CONT. EQ. FOR HAZ LOC. CL I, DIV 2 GP A,B,C,D TEMP CODE T4

INPUT POWER: 24VDC 250mA TambMax= 55°C RoHS Stationsgatan 37 302 45 Halmstad Sweden

WARNING: DO NOT USE USB CONNECTOR WHILE CIRCUIT IS LIVE UNLESS THE AREA IS KNOWN TO BE FREE OF IGNITIBLE CONCENTRATIONS OF FLAMMABLE GASES OR VAPORS

MFD. 10 04/12 MADE IN SWEDEN HMS

HMS Industrial Networks AB
Stationsgatan 37
302 45 Halmstad
Sweden



Further information and documents about this product can be found at the product pages on www.anybus.com.