

Anybus X-gateway CANopen - PROFINET INSTALLATION SHEET



HMS Industrial Networks AB
Web: www.anybus.com
Tel: +46 35 172900
E-mail: info@hms.se



SP1197, rev 2.00, Apr 2012. AB7307.

www.anybus.com

Module Front

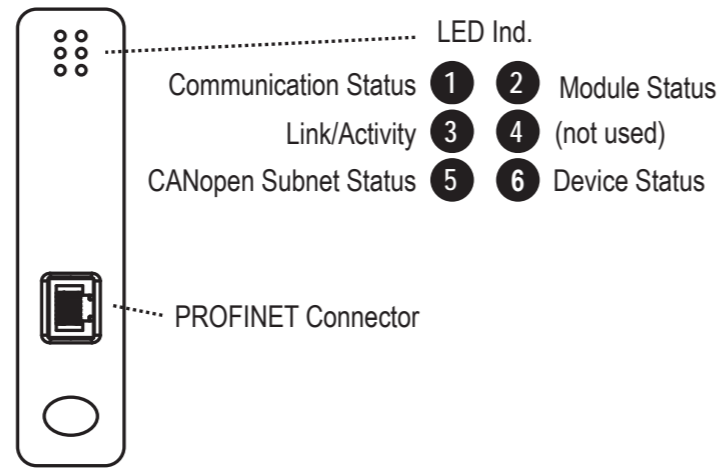

Network Access Port

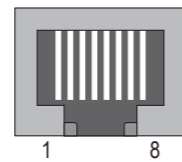

Pin no	Description
1	TX+
2	TX-
3	RX+
6	RX-
4, 5, 7, 8	Termination

LED Indicators

LED no	Indication	Meaning
1 (Communication Status)	Off	Not online
	Green	Online, connection with IO established, IO controller in run state
2 (Module status)	Flashing green	Online, connection with IO established, IO controller in stop state
	Off	Module initialized
	Green	Module initialized, no errors
	Single flash, green	Diagnostics available
	Double flash, green	Used by engineering tool to identify the module
	Single flash, red	Configuration error
3 (Link/Activity)	Triple flash, red	No station name or no IP address assigned
	Quadruple flash, red	Failed to initialize PROFINET IO object or no MAC address
	Off	No link
	Green	Link established
	Flashing green	Packet is recieved or transmitted
4 (not used)	-	-
5 (CANopen Subnet Status)	Off	Power off
	Flickering green/red	The LSS services are in progress
	Blinking green	Pre-operational state
	Single flash, green	Stopped state
	Green	Operational state
	Blinking red	Configuration error
	Single flash, red	Warning limit reached
	Double flash, red	Error control event
	Triple flash, red	Sync error
	Quadruple flash, red	Data communication timeout
Red	Bus off	
6 (Device Status)	Off	Power off
	Single flash, green	Bootup
	Green	Running
	Single flash, red	Initialization error
	Double flash, red	Timeout
	Triple flash, red	Hardware failure
	Quadruple flash, red	General error
	Red	Fatal error

1. This LED shows the status of the CANopen subnet that is controlled by the X-Gateway CANopen.

Accessories Checklist

The following items are required for installation:

CANopen:

- CANopen configuration tool (available at www.anybus.com)
- CANopen adapter for configuration tool (not included)
- CANopen cable (not included)
- EDS file, available at www.anybus.com

PROFINET IO Interface:

- Suitable LAN cable (not included)
- PROFINET configuration tool (not included)
- GSD file, available at www.anybus.com

Installation and Startup Summary

- Select baud rate and an unused node address for the interface. (Cover the switches with the enclosed switch covers.)
- Connect the gateway to the CANopen network.
- Install the EDS file in the CANopen configuration tool.
- Power up and (if required) configure the module.
- Restart the module after the CANopen interface has been configured.
- Connect the gateway to the PROFINET network.
- Install the GSD file in the PROFINET configuration tool.
- Power up and (if required) configure the module.

Please note that the module will start up as a CANopen slave. The module can be reconfigured as a CANopen master during configuration.

Side View

Setting	Baud Rate (kbit/s)
0	20
1	50
2	125
3	250
4	500
5	800
6	1000
7	Auto
8, 9	Not available

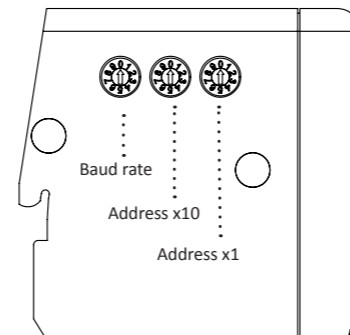

Allowed node address range is 1 - 127. Addresses 1 - 99 are available using the address rotary switches. To set e.g. node address 42, set the left address switch to 4 and the right address switch to 2. Cover the switches with the enclosed switch covers to ensure EMC compliance.

Bottom View

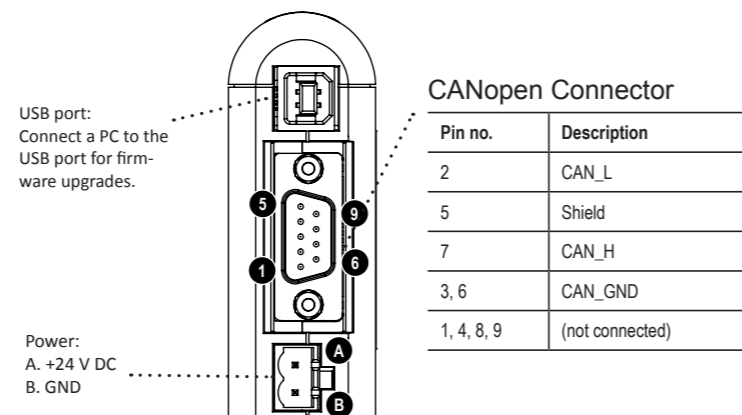

Technical Details

- Power supply:
24 V DC (-10% to +10%).
- Power consumption:
Maximum power consumption is 250 mA @ 24 V DC.
Typical power consumption: 100 mA @ 24 V DC.
- Protective Earth (PE):
Internal connection to PE via DIN-rail.
Note: Make sure the DIN-rail is properly connected to PE.

CANopen Support

Technical support regarding the CANopen fieldbus system should be addressed to CAN in Automation (CiA).
Online: www.can-cia.org

PROFINET IO Support

Technical questions regarding the PROFINET IO fieldbus system should be addressed to your local PROFINET user group.
Online: www.profinet.org

For maintenance and support, contact the HMS support department. Contact information is available at the support pages at www.anybus.com.

Further information and documents about this product can be found at the product pages on www.anybus.com.

Anybus X-gateway CANopen INSTALLATION SHEET

DIN-rail Mounting

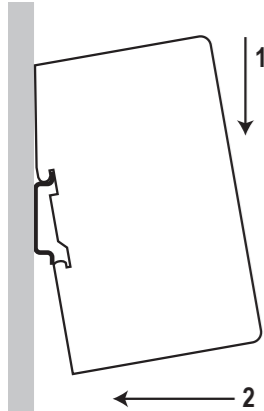

To snap the gateway on, first press it downwards (1) to compress the spring in the DIN-rail mechanism, then push it against the DIN-rail as to make it snap on (2).

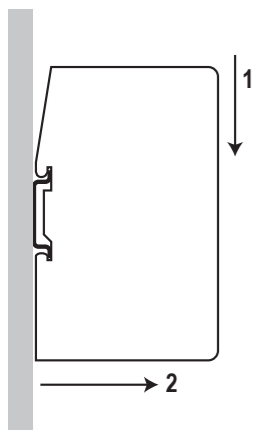

To snap the gateway off, push it downwards (1) and pull it out from the DIN-rail (2), as to make it snap off from the DIN-rail.

Additional Installation and Operating Instructions

Supply voltage: The X-gateway requires a regulated 24 V (21.6 V to 26.4 V) DC power source.

Field wiring terminal markings (wire type (Cu only, 14-30AWG)
"Use 60/75 or 75°C copper (CU) wire only"
Terminal tightening torque (5-7 lb-in (0.5 - 0.8 Nm)).

Use in Overvoltage Category I Pollution Degree 2 Environment.

Install in an enclosure considered representative of the intended use. To comply with ATEX directives, the equipment must be installed within an IP54 enclosure and must be installed with a transient suppressor on the supply that does not exceed 140% (33.6 V DC) of the nominal rated supply voltage.

Operating temperature/Surrounding temperature:
-25 to +55 degrees C @ 250 mA @ 24 V DC.

Maximum surface temperature: 135 degrees C.

Pressure: 850 - 1050 millibar.

This product is designed to safely operate in class I, division 2 Hazardous location according to ANSI/ISA 12.12.01-2011 and category 3, zone 2 according to EN 60079-0, EN 60079-11, and EN 60079-15.

SUITABLE FOR USE IN CLASS I, DIVISION 2, GROUPS A, B, C AND D HAZARDOUS LOCATIONS, OR NONHAZARDOUS LOCATIONS ONLY.

Warnings

- **WARNING - EXPLOSION HAZARD - SUBSTITUTION OF ANY COMPONENTS MAY IMPAIR SUITABILITY FOR CLASS I, DIVISION 2.**
- **WARNING - EXPLOSION HAZARD - WHEN IN HAZARDOUS LOCATIONS, TURN OFF POWER BEFORE REPLACING OR WIRING MODULES.**
- **WARNING - EXPLOSION HAZARD - DO NOT DISCONNECT EQUIPMENT WHILE THE CIRCUIT IS LIVE OR UNLESS THE AREA IS KNOWN TO BE FREE OF IGNITABLE CONCENTRATIONS.**
- **WARNING - EXPLOSION HAZARD - THE USB CONNECTOR IS NOT FOR USE IN HAZARDOUS LOCATIONS AND FOR TEMPORARY CONNECTION ONLY. DO NOT USE, CONNECT OR DISCONNECT UNLESS THE AREA IS KNOWN TO BE NONHAZARDOUS. CONNECTION OR DISCONNECTION IN AN EXPLOSIVE ATMOSPHERE COULD RESULT IN AN EXPLOSION.**
- **WARNING - INSTALL IN AN ENCLOSURE CONSIDERED REPRESENTATIVE OF THE INTENDED USE. TO COMPLY WITH ATEX DIRECTIVES, THE EQUIPMENT MUST BE INSTALLED WITHIN AN IP54 ENCLOSURE AND MUST BE INSTALLED WITH A TRANSIENT SUPPRESSOR ON THE SUPPLY THAT DOES NOT EXCEED 140% (33.6 V DC) OF THE NOMINAL RATED SUPPLY VOLTAGE.**

UL Certification



LISTED 67AM

Atex Certification

EX nA ic IIC T4 Gc



DEMKO 12 ATEX 1062548X

EMC Compliance (CE)



This product is in accordance with the EMC directive 2004/108/EC through conformance with the following standards:

- **EN 61000-6-4 (2007)**
Emission standard for industrial environment
EN 55016-2-3, Class A (2006)
- **EN 61000-6-2 (2005)**
Immunity for industrial environment
EN 61000-4-2 (2009)
EN 61000-4-3 (2006)
EN 61000-4-4 (2004)
EN 61000-4-5 (2005)
EN 61000-4-6 (2007)

Label Markings

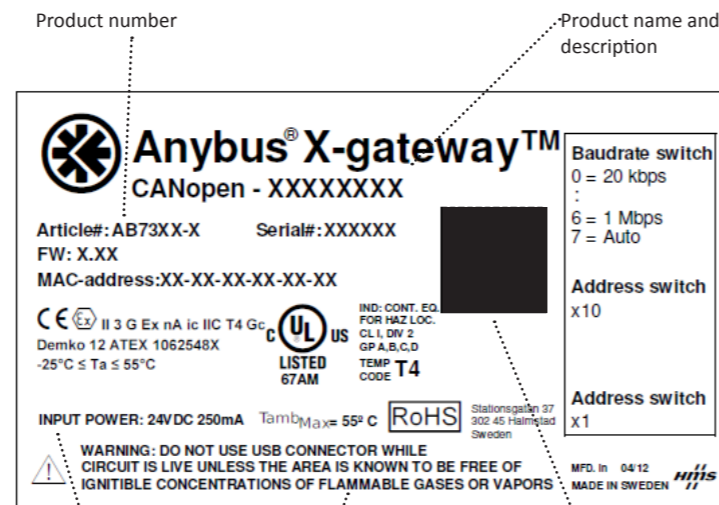

Surrounding air temperature and electrical ratings

Warnings

Product information bar code

HMS Industrial Networks AB
Stationsgatan 37
302 45 Halmstad
Sweden



Further information and documents about this product can be found at the product pages on www.anybus.com.