

X-gateway Interface Addendum Profibus Master

Doc: HMSI-27-250
Rev: 2.00



HALMSTAD • CHICAGO • KARLSRUHE • TOKYO • BEIJING • MILANO • MULHOUSE • COVENTRY • PUNE • COPENHAGEN

HMS Industrial Networks
Mailing address: Box 4126, 300 04 Halmstad, Sweden
Visiting address: Stationsgatan 37, Halmstad, Sweden

E-mail: info@hms-networks.com
www.hms-networks.com

Important User Information

This document is intended to provide a good understanding of the functionality offered by the Interface described here.

The reader is expected to be familiar with high level software design, and communication systems in general. The use of advanced interface-specific functionality may require in-depth knowledge of networking internals and/or information from the network specifications. In such cases, the persons responsible for the implementation of this product should either obtain the necessary specifications to gain sufficient knowledge, or alternatively limit the implementation in such a way that this is not necessary.

Liability

Every care has been taken in the preparation of this manual. Please inform HMS Industrial Networks AB of any inaccuracies or omissions. The data and illustrations found in this document are not binding. We, HMS Industrial Networks AB, reserve the right to modify our products in line with our policy of continuous product development. The information in this document is subject to change without notice and should not be considered as a commitment by HMS Industrial Networks AB. HMS Industrial Networks AB assumes no responsibility for any errors that may appear in this document.

There are many applications of this product. Those responsible for the use of this device must ensure that all the necessary steps have been taken to verify that the applications meet all performance and safety requirements including any applicable laws, regulations, codes, and standards.

HMS Industrial Networks AB will under no circumstances assume liability or responsibility for any problems that may arise as a result from the use of undocumented features, timing, or functional side effects found outside the documented scope of this product. The effects caused by any direct or indirect use of such aspects of the product are undefined, and may include e.g. compatibility issues and stability issues.

The examples and illustrations in this document are included solely for illustrative purposes. Because of the many variables and requirements associated with any particular implementation, HMS Industrial Networks AB cannot assume responsibility for actual use based on these examples and illustrations.

Intellectual Property Rights

HMS Industrial Networks AB has intellectual property rights relating to technology embodied in the product described in this document. These intellectual property rights may include patents and pending patent applications in the US and other countries.

Trademark Acknowledgements

Anybus ® is a registered trademark of HMS Industrial Networks AB. All other trademarks are the property of their respective holders.

!

WARNING: This is a class A product. in a domestic environment this product may cause radio interference in which case the user may be required to take adequate measures.

ESD Note: This product contains ESD (Electrostatic Discharge) sensitive parts that may be damaged if ESD control procedures are not followed. Static control precautions are required when handling the product. Failure to observe this may cause damage to the product.

Table of Contents

Preface	About This Document	
	How To Use This Document	P-1
	Important User Information	P-1
	Related Documents.....	P-2
	Document History	P-2
	Conventions & Terminology.....	P-2
	Sales and Support	P-2
Chapter 1	About the PROFIBUS Master	
	Basic Operation	
	General Description.....	1-2
	Features	1-2
	Status LEDs	1-3
	<i>Connectors</i>	1-3
Chapter 2	Data Exchange	
	General Information.....	2-1
	Control & Status Word Implementation Details	2-1
	<i>Status Word</i>	2-1
	<i>Control Word</i>	2-2
	Live List Implementation Details	2-2
Chapter 3	Gateway Config Interface	
	General Information.....	3-1
	Operation Modes	3-1
	Configuration Settings.....	3-1
Chapter 4	PROFIBUS Config Interface	
	General Information.....	4-1
	HMS Transport Provider	4-1
	Configuration Example	4-2
Appendix A	Technical Specification	
	PROFIBUS Interface Pinout	A-1
	PROFIBUS Config Interface Pinout	A-1

P. About This Document

P.1 How To Use This Document

This document describes the various features of the PROFIBUS Master for the X-gateway, basic network installation procedures and other network specific details. General information and operating instructions for the gateway is available in the main User Manual.

The reader of this document is expected to be familiar with the PROFIBUS networking system, and communication systems in general.

For further information, documentation etc., please visit www.anybus.com

P.2 Related Documents

Document	Author
Anybus X-Gateway User Manual	HMS
Anybus-M PROFIBUS DPV Fieldbus Appendix	

P.3 Document History

Revision List

Revision	Date	Author	Chapter	Description
1.00	2005-02-14	PeP	All	First release
1.10	2007-08-16	PeP	All	Document rewritten to match main user manual
1.11	2010-01-29	KeL	2, 3	Minor updates
2.00	May 2014	SDa	Multiple	New hardware & Anybus Configuration Manager

P.4 Conventions & Terminology

The following conventions are used throughout this document:

- Numbered lists provide sequential steps
- Bulleted lists provide information, not procedural steps
- The term 'Master interface' refers to the PROFIBUS Master interface for the X-gateway
- The term 'Slave interface' or 'other network' refers to the other, 'non PROFIBUS'-side of the gateway.
- The term 'user manual' is used when referring to the Anybus X-gateway User Manual.
- Hexadecimal values are written in the format NNNNh, where NNNN is the hexadecimal value.

P.5 Sales and Support

For general contact information and support, please refer to the contact and support pages at www.anybus.com.

1. About the PROFIBUS Master

1.1 General Description

The PROFIBUS Master interface for the Anybus X-gateway allows up to 125 PROFIBUS slaves to exchange data with another network.

The interface features an on-board configuration interface, which is used to interface the master with the Anybus NetTool for PROFIBUS configuration software.

Like all X-gateway interfaces, the PROFIBUS Master exchanges data via two buffers as follows:

- **Input Buffer**

This buffer holds data *from* the other network, i.e. data which will be sent *to* the slaves on the PROFIBUS network.

- **Output Buffer**

This buffer holds data *from* the slaves on the PROFIBUS network, i.e. data which will be sent *to* the other network.

Apart from network I/O, this can optionally also include general status information from the PROFIBUS network (Live List).

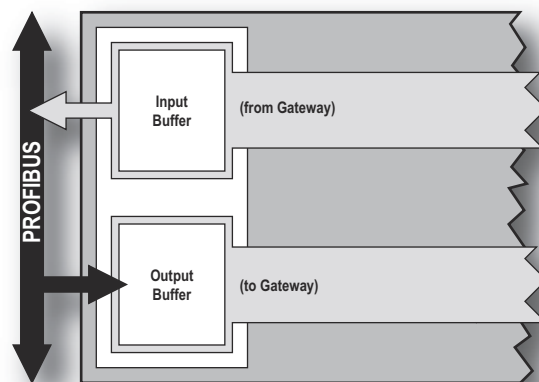

1.2 Features

- Controls up to 125 slaves
- Supports all baudrates up to 12Mbit/s
- Up to 512 bytes of I/O in each direction
- Configuration via RS-232 or Ethernet (where applicable)
- Compatible with Anybus NetTool for PROFIBUS
- Galvanically isolated bus electronics

1.3 Status LEDs

LED	State	Indication
Gateway Status	Consult the Gateway user manual for further details	
MS	Off	Master is offline
	Red	Master is in STOP mode
	Green, flashing	Master is in CLEAR mode
	Green	Master is in OPERATE mode
DB	Off	No database
	Green	Database OK
	Green, flashing	Database download in progress
	Red	Database invalid
COM	Off	No data exchange
	Green	Data exchange with all slaves
	Green, flashing	Data exchange with at least one slave
	Red	Bus control error
TOK	Off	Another station holds the token
	Green	Master interface holds the token

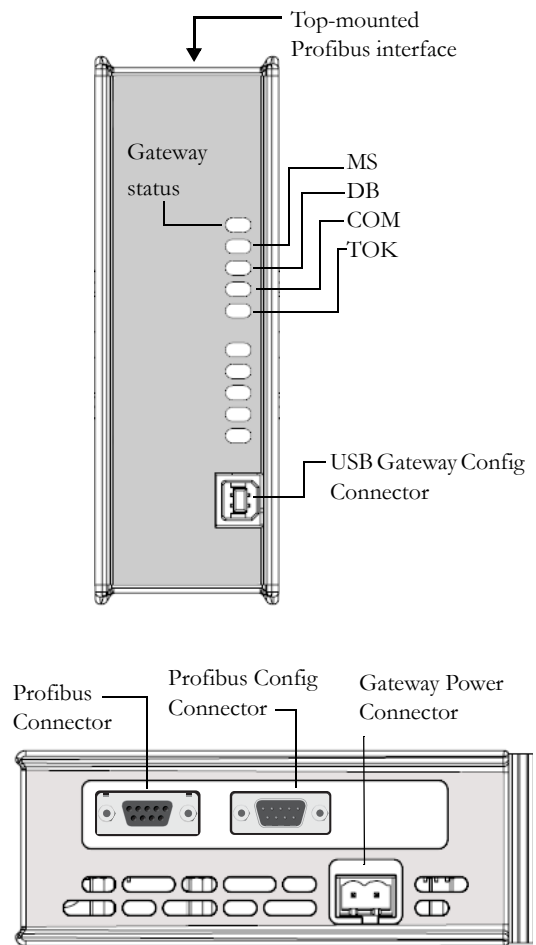

1.4 Connectors

PROFIBUS connector

See A-13 “PROFIBUS Interface Pinout”.

PROFIBUS Config connector

See A-13 “PROFIBUS Config Interface Pinout”.

Gateway power connector

See the X-gateway user manual for further details.

USB Gateway Config connector

See the X-gateway user manual for further details.

IMPORTANT: Due to the mechanical design of the Master interface, the PROFIBUS Config Connector is blocked when using standard PROFIBUS connectors. This is not generally an issue when the master is up and running, but in order to be able to use the online features in Anybus NetTool for PROFIBUS, a reversed connector is required.

Manufacturer	Direction	Part No.
Erni	Standard	134928
	Reversed	104577
Siemens	Standard	6GK1 500-0FC00
	Reversed	6ES7 972-0BA50-0XA0
		6ES7 972-0BB50-0XA0

2. Data Exchange

2.1 General Information

The Master interface exchanges data with up to 125 slaves. This data (from now on referred to as PROFIBUS Slave Data) is forwarded to the Slave Interface side of the gateway and vice versa according to the figure below.

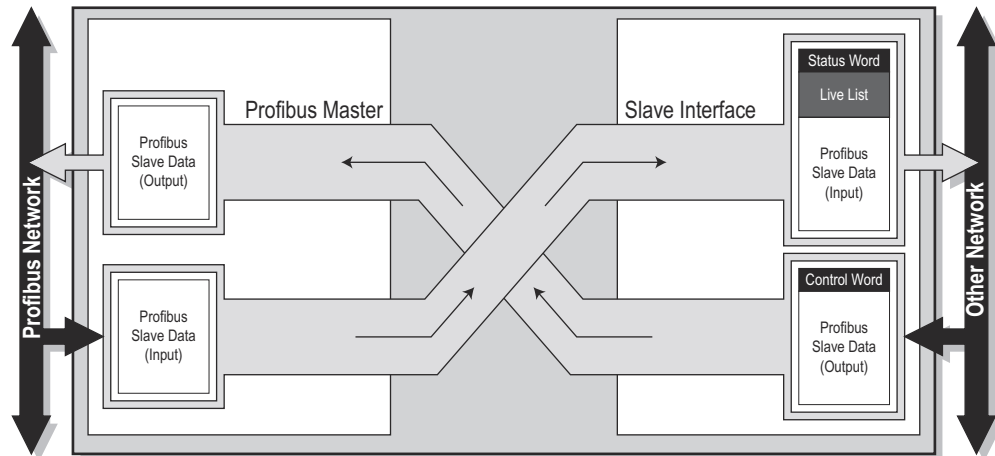

The structure of the PROFIBUS Slave Data is determined by the slave database created using the PROFIBUS configuration tool (in this case Anybus NetTool for PROFIBUS).

Note: The I/O sizes for the Master interface is determined by the size of the actual configuration created using the PROFIBUS configuration tool (in this case Anybus NetTool for PROFIBUS) and cannot be set via the Gateway Config interface.

See also...

- 3-10 “Gateway Config Interface”

2.2 Control & Status Word Implementation Details

2.2.1 Status Word

The Status Word holds general status information from the gateway.

Consult the user manual for further information.

2.2.2 Control Word

The Control Word, if enabled, controls the communication towards the slaves on the PROFIBUS network.

Control Word Contents:



Mode	Meaning	Comments
00b	Stop	These settings are also available from the Gateway Config interface. See also... - 3-10 "The online help in ACM, for further help on the available settings."
01b	Offline	
10b	Clear	
11b	Operate	

Reset	Meaning	Comments
0b	Normal operation	-
1b	Reset gateway	Setting this bit causes the gateway to perform a self-reset.

IMPORTANT: *The Control- and Status Words can be disabled via the Gateway Configuration Interface. In this case, the master interface will enter 'Operate' mode automatically after having completed the startup initialisation sequence.*

2.3 Live List Implementation Details

The Live List holds bit coded status information for PROFIBUS slaves 0-63. A set bit indicates that the corresponding slave is in data transfer, a cleared bit indicates that the slave is not exchanging data. Please note that the master exchanges data with slaves 64... 125 even though these slaves are not represented in the Live List.

For more information regarding the Live List, consult the main user manual.

3. Gateway Config Interface

The X-Gateway and the Profibus interface may be configured by using the software tool **Anybus Configuration Manager** (ACM), which is available from www.anybus.com/support

When ACM is connected to the gateway via the USB configuration connector, the following settings are available:

Network Type

Name	PROFIBUS Master
------	-----------------

General

Offline option	Clear ▼
Control word/Status word	Disable ▼

Fieldbus Specific

Live list	Disable ▼
-----------	-----------

See also...

- The Anybus X-gateway User Manual, for full details on using ACM.
- The online help in ACM, for further help on the available settings.

4. PROFIBUS Config Interface

4.1 General Information

The PROFIBUS Config Interface can be used to interface the master with the Anybus NetTool for PROFIBUS configuration software. Anybus NetTool for PROFIBUS is user friendly PROFIBUS configuration tool suitable for the X-gateway. A fast learning curve and an intuitive visual user interface allows complete network configurations to be built without spending precious time learning a new program.

Anybus NetTool for PROFIBUS is ordered separately, however a free trial version (limited to 2 slaves) can be downloaded from www.anybus.com

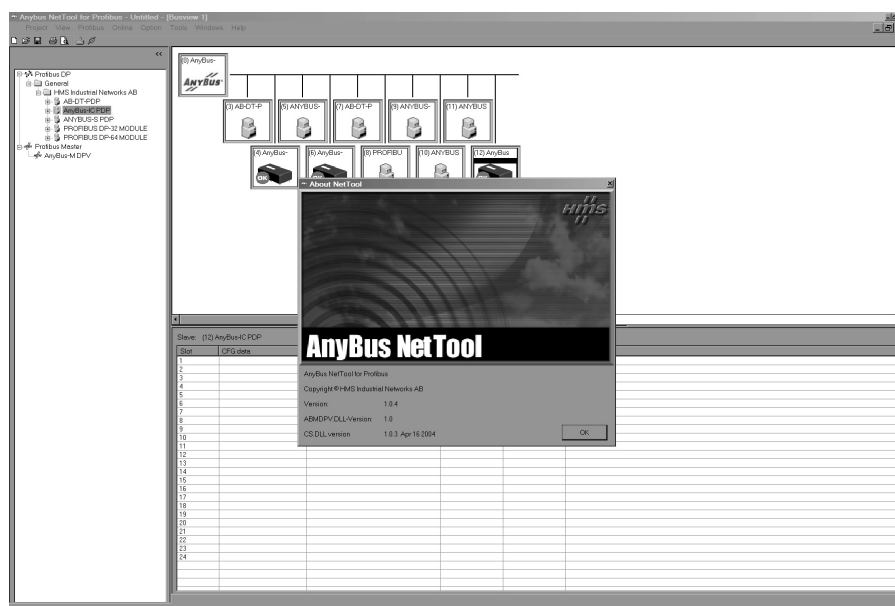

For more information, consult the Anybus-NetTool for PROFIBUS documentation (online help).

See also...

- 4-12 “Configuration Example”.

4.2 HMS Transport Provider

Anybus NetTool for PROFIBUS supports the HMS Transport Provider, which allows it to control- and configure the PROFIBUS master interface via Ethernet on supported gateway configurations.

Gateway configurations which supports the HMS Transport Provider:

- PROFINET Slave to PROFIBUS Master
- Ethernet Slave to PROFIBUS Master

For more information regarding these products, consult their respective network interface addendums.

4.3 Configuration Example

In this example, a network consisting of 3 slaves and a master (in this case the Master interface) has been created using Anybus NetTool for PROFIBUS.

- **Node 0 (Master)**
-
- **Node 3**
Slot 1: 128 byte in, 128 byte out
Slot 2: 32 bytes out
- **Node 4**
Slot 1: 32 bytes out
- **Node 5**
Slot 1: 32 bytes in
Slot 2: 64 bytes out

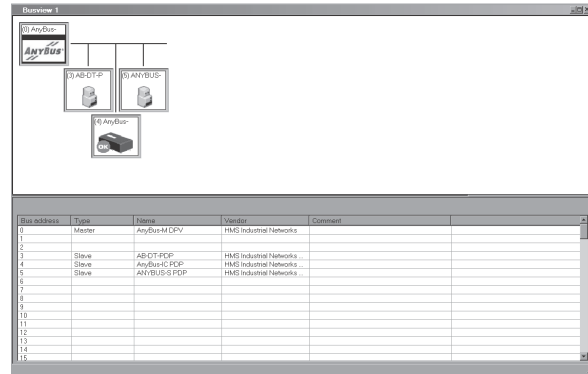

The resulting slave I/O map can be viewed under 'PROFIBUS\Slave I/O address overview'.

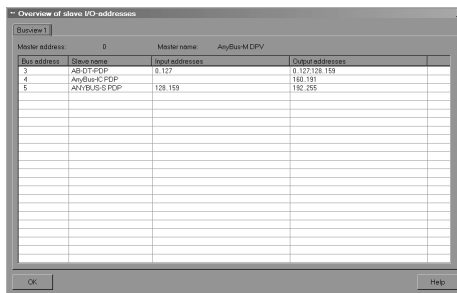

Node	Input Range	Output Range
3	0...127	0...127 128...159
4	-	160...191
5	128...159	192...255

The slave I/O map is also reflected in the Input- and Output data exchange buffers in the Master interface as follows:

Slave Input Data Structure

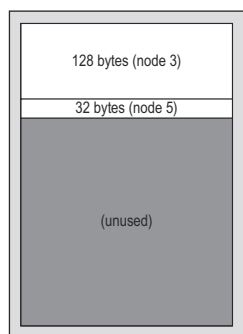

Slave Output Data Structure

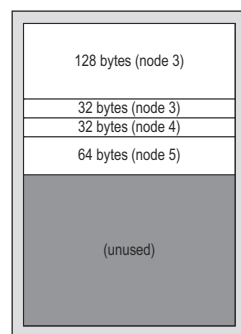

A. Technical Specification

A.1 PROFIBUS Interface Pinout

Pin	Signal
1	-
2	-
3	B-Line
4	RTS
5	GND_BUS
6	+5V BUS (output)
7	-
8	A-Line
9	-
Housing	Cable Shield

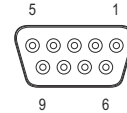

A.2 PROFIBUS Config Interface Pinout

Pin	Signal
1	-
2	RS232 Receive
3	RS232 Transmit
4	-
5	Ground
6	-
7	-
8	-
9	-
Housing	Protective Earth

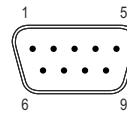

Note: The PROFIBUS Config Interface is a DTE device, i.e. a null modem (cross over) cable must be used when connecting it to another DTE device (e.g. a PC).