

# iPC-I XC16/PCI

## Intelligent PC/CAN Interface

---

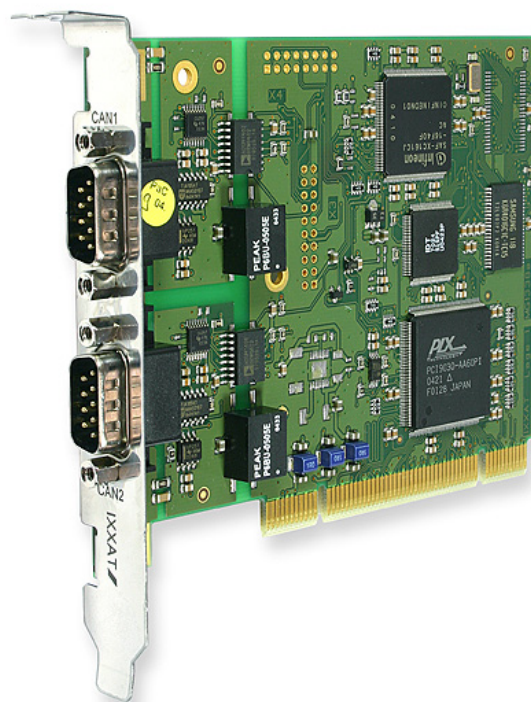



IXXAT Automation GmbH  
Leibnizstr. 15  
D-88250 Weingarten

Tel.: +49 (0)7 51 / 5 61 46-0  
Fax: +49 (0)7 51 / 5 61 46-29  
Internet: [www.ixxat.de](http://www.ixxat.de)  
e-Mail: [info@ixxat.de](mailto:info@ixxat.de)

## Support

In case of unsolvable problems with this product or other IXXAT products please contact IXXAT in written form by:

Fax: +49 (0)7 51 / 5 61 46-29  
e-Mail: [support@ixxat.de](mailto:support@ixxat.de)

## Copyright

Duplication (copying, printing, microfilm or other forms) and the electronic distribution of this document is only allowed with explicit permission of IXXAT Automation GmbH. IXXAT Automation GmbH reserves the right to change technical data without prior announcement. The general business conditions and the regulations of the license agreement do apply. All rights are reserved.

<b>1</b>	<b>Introduction .....</b>	<b>5</b>
	<b>1.1 Overview .....</b>	<b>5</b>
	<b>1.2 Features .....</b>	<b>5</b>
<b>2</b>	<b>Installation.....</b>	<b>6</b>
	<b>2.1 Software installation .....</b>	<b>6</b>
	<b>2.2 Hardware installation .....</b>	<b>6</b>
<b>3</b>	<b>Connections and displays.....</b>	<b>6</b>
	<b>3.1 Pin assignment .....</b>	<b>6</b>
	3.1.1 CAN bus connection.....	6
	3.1.2 PCI bus connection.....	8
	<b>3.2 CAN bus terminal.....</b>	<b>8</b>
<b>4</b>	<b>Firmware update .....</b>	<b>9</b>
<b>5</b>	<b>Appendix .....</b>	<b>10</b>
	<b>5.1 Support.....</b>	<b>10</b>
	<b>5.2 Returning hardware.....</b>	<b>10</b>
	<b>5.3 Note on disposal of used devices .....</b>	<b>10</b>
	<b>5.4 Technical specifications.....</b>	<b>12</b>
	<b>5.5 Accessories.....</b>	<b>13</b>
	CAN bus terminal resistor .....	13
	<b>5.6 FCC Compliance .....</b>	<b>13</b>
	<b>5.7 EC Declaration of Conformity.....</b>	<b>14</b>



# 1 Introduction

## 1.1 Overview

The IXXAT PC-CAN interface iPC-I XC16/PCI is a powerful electronic component, developed and manufactured in accordance with the latest technological standards. This manual is intended to familiarize you with your iPC-I XC16/PCI interface. Please read this manual before beginning with installation.

## 1.2 Features

- PCI – connection in accordance with PCI specification 2.2, 32-bit, 33MHz
- Utilizable in both 5V and 3.3V PCI signal environment
- Infineon 16-bit microcontroller with 40MHz clock
- 512 kByte RAM, 128 kByte Flash
- Data exchange between PC and microcontroller system via 8kB dual-port RAM
- 2 independent CAN lines
- CAN bus connection in accordance with ISO 11898-2 (high-speed), as an option galvanically isolated
- Automotive version: CAN bus connection in accordance with ISO 11898-2, switchable to CAN bus connection in accordance with ISO 11898-3 (low-speed), both galvanically isolated. Each CAN bus connection can be switched over independently

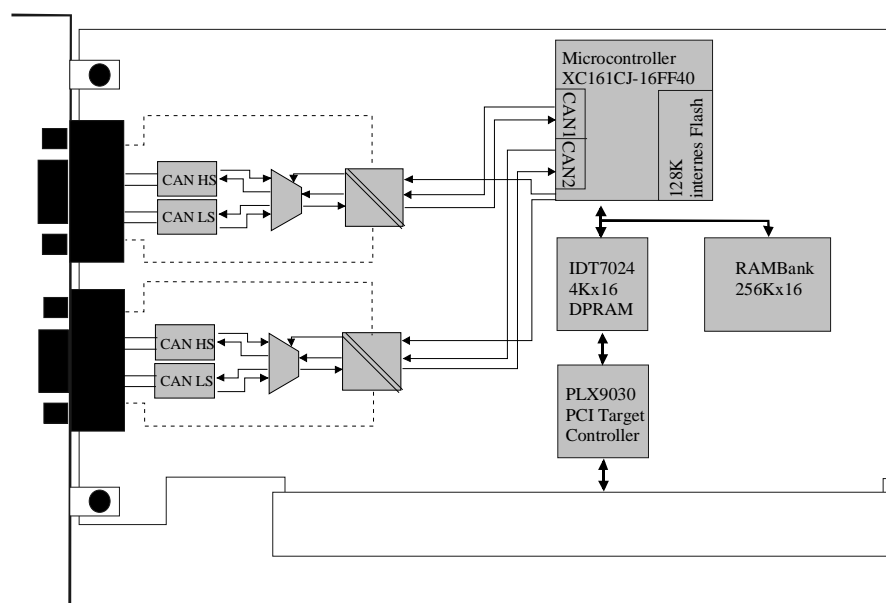

Fig. 1-1: Block diagram of iPC-I XC16/PCI

# 2 Installation

## 2.1 Software installation

A PC driver is required to operate the interface. This driver is an integral part of the VCI (Virtual CAN Interface), which can be downloaded free of charge from the Internet at <http://www.ixxat.de>.

For installation of the VCI driver under Windows, please refer to the VCI installation manual.

## 2.2 Hardware installation

Before inserting the iPC-I XC16/PCI in the PCI slot, you should install the software driver (see previous section).

For all work on the PC and interface, you must be statically discharged. Work must be carried out on an earthed, anti-static work mat.

Take the following steps in sequence:

- (1) Switch the PC off and remove the mains plug.
- (2) Open the PC according to the instructions of the PC manufacturer and find a suitable slot.  
The interface is designed according to the PC standard and can easily be installed the computer. Do not use force when plugging in.
- (3) Make sure the interface sits tightly in the PC.
- (4) Close the PC; the hardware installation is now complete.

# 3 Connections and displays

## 3.1 Pin assignment

### 3.1.1 CAN bus connection

The iPC-IXC16/PCI has a bus connection in accordance with ISO 11898-2, optionally switchable to ISO 11898-3 (automotive version) for each CAN line. The signals for CAN line 1 are connected to the upper Sub-D connector, the signals for CAN line 2 to the lower Sub-DF connector (see Fig. 3-1).

The shield of the CAN socket is connected to the ground of the CAN connection via a 1 M $\Omega$  resistor and a 10nF capacitor to the ground of the CAN connection. The shields of the CAN sockets are connected directly with each other.

In the case of a non-galvanically isolated device version, CAN-ground and PC-ground are connected to the same potential.

Maximum interference immunity is achieved when the shield of the CAN cable is earthed.

The assignment of the Sub-D connector is shown in Table 3-1. As an option, the bus connection can be galvanically isolated from the CAN bus.

Pin no.	Signal
1	CAN-low (fault tolerant), (only automotive version)
2	CAN-low
3	GND
4	CAN-high (fault tolerant), (only automotive version)
5	Not connected
6	Not connected
7	CAN-high
8	Not connected
9	Not connected

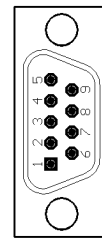

**Table 3-1: Pin assignment of the CAN bus connection**

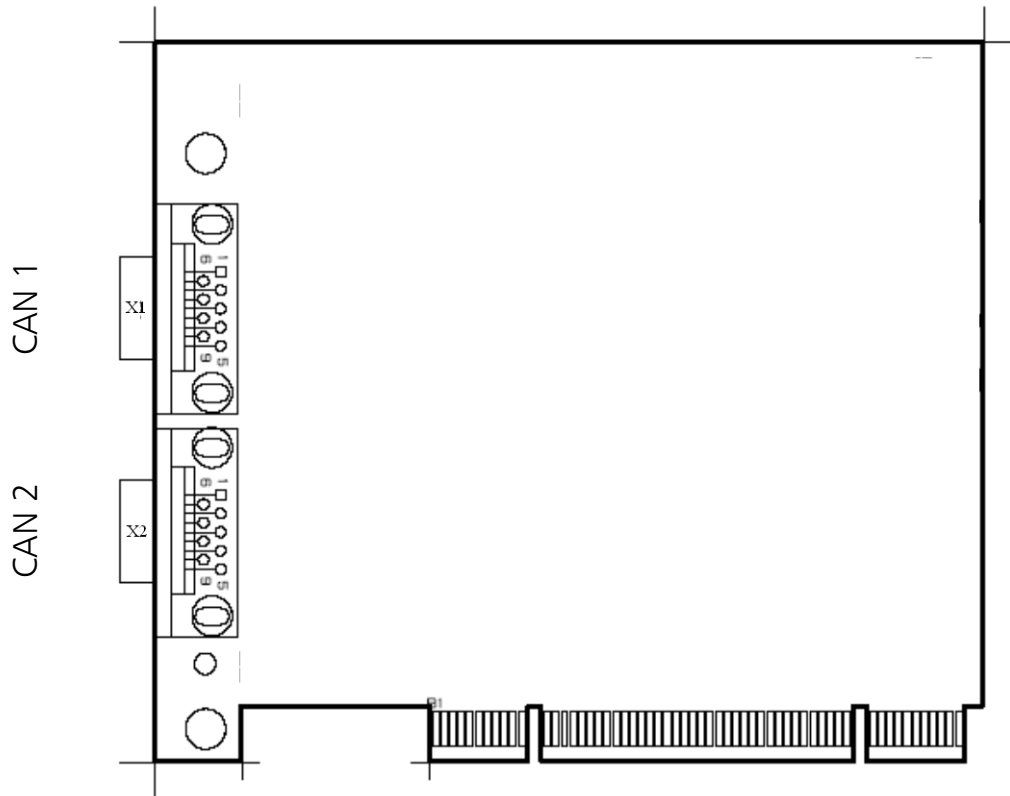

**Fig. 3-1 Position of the CAN connections**

### 3.1.2 PCI bus connection

The assignment of the PCI connector is designed in accordance with the PCI specification 2.2. The iPC-I XC16/PCI can be operated both in a 3.3V and in a 5V PCI signal environment. The maximum PCI bus frequency with which the interface can be operated is 33MHz.

### 3.2 CAN bus termination

There is no bus termination resistor (120 Ohm) for the CAN bus on the iPC-I XC16/PCI.

A bus terminal resistor in the form of a feed-through connector is available as an accessory from IXXAT (order number 1.04.0075.03000).



### 4 Firmware update

For reasons of speed, the software on the card is run in the flash of the microcontroller. The card is always supplied with the latest UCI firmware in the flash. The VCI can be operated with this firmware. If you require different firmware (e.g. for the CANopen Master API, BCI etc.) or an update of the UCI firmware becomes necessary, you can download the necessary files and tools in the download section of our website.

# 5 Appendix

## 5.1 Support

For more information on our products, FAQ lists and installation tips, please refer to the support section of our website (<http://www.ixxat.de>), which also contains information on current product versions and available updates.

If you have any further questions after studying the information on our website and the manuals, please contact our support department. The support section on our website contains the relevant forms for your support request. In order to facilitate our support work and enable a fast response, please provide precise information on the individual points and describe your question or problem in detail.

If you would prefer to contact our support department by phone, please also send a support request via our website first, so that our support department has the relevant information available.

## 5.2 Returning hardware

To enable fast, correct processing of returns, please apply for an RMA number before returning hardware using our on-line "RMA form", which you will find in the Support section on our website.

After applying for the RMA number, you will receive a return delivery note from us, which you should enclose with the return delivery. If returns are made without an RMA number or a return delivery note, we reserve the right to return the delivery at your expense. A detailed description of the RMA procedure can be found in the Support section on our website.

## 5.3 Note on disposal of used devices

This product is subject to the ElektroG (electrical and electronic equipment act) and is to be disposed of in accordance with this act. The products of IXXAT that are subject to the ElektroG are devices for exclusive commercial use and are marked with the symbol of the crossed out garbage can.



Based on the B2B regulation, disposal is governed separately in the Terms of Sale of IXXAT in accordance with § 10 para. 2 clause 3 of the Electrical and Electronic Equipment Act (ElektroG) in the version of 16.03.2005.

When products supplied by IXXAT are no longer used, the customer is obliged to dispose these products at his/her own expense. It is to be noted that, unlike privately used devices (B2C), they may not be disposed of at the collection centers of public disposal contractors (e.g. municipal recycling centers). The statutory regulations for disposal are to be complied with.

If products delivered were passed on to third parties, the customer is obliged to take back the delivered products at his/her expense when no longer used and to correctly dispose of them in accordance with the statutory regulations or to impose these obligations on the third parties.

The Terms of Sale and their supplements as well as further information on the disposal of used devices can be downloaded from [www.ixxat.com](http://www.ixxat.com).

### 5.4 Technical specifications

PCI interface:	32 Bit/33 MHz, PCI Specification 2.2
Microcontroller:	Infineon XC161CJ, 40 MHz
RAM / Flash:	512 kByte / 128 kByte
CAN controller:	TwinCAN (integrated in the microcontroller)
CAN transceiver (high-speed):	Texas Instruments SN65HVD251
CAN transceiver (low-speed):	Philips TJA1054
Max. number of CAN bus nodes:	120 (high-speed), 32 (low-speed)
CAN bus terminal resistor:	none (high-speed), RTH=RTL=4,7k $\Omega$ (low-speed)
CAN run delay:	with galv. isolation typically 32 ns, max. 50ns
CAN baud rates:	10 kBaud – 1 MBaud (high-speed), 10 kBaud - 125 kBaud (low-speed)
Max. CAN throughput (with VCI):	42,000 messages/s
Power supply:	via PCI slot (5V DC and 3.3V DC)
Power consumption normal operation:	typically 100 mA (5V DC), 185 mA (3.3 V DC)
Dimensions:	123 x 90 mm
Weight:	approx. 87 g
Working temperature range:	-20°C .. +70°C
Storage temperature range:	-40°C .. +85°C
Relative humidity:	10 - 95%, non-condensing
Galvanic isolation:	1000V DC between CAN bus and internal logic
Device safety:	CSA/UL 60950-00 Class 3862 10, 3862 90

## 5.5 Accessories

### CAN bus termination resistor

To terminate the CAN bus, a Sub-D9 feed-through connector with integrated 120 Ohm bus termination resistor is available.

Order number: 1.04.0075.03000

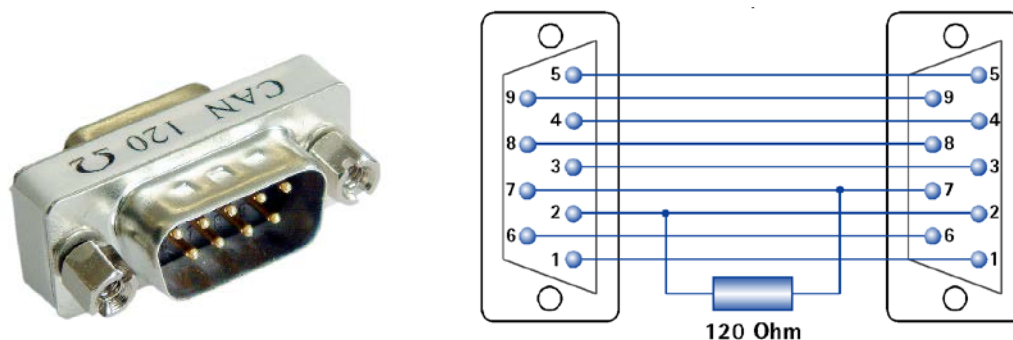

Fig. 4-1: CAN bus terminal resistor and internal wiring

## 5.6 FCC Compliance

### Declaration of conformity

This device complies with Part 15 of the FCC Rules. Operation is subject to the following two conditions:

- this device may not cause harmful interference, and
- this device must accept any interference received, including interference that may cause undesired operation.

### Class A digital device instructions:

Note: This equipment has been tested and found to comply with the limits for a Class A digital device, pursuant to Part 15 of the FCC Rules. These limits are designed to provide reasonable protection against harmful interference when the equipment is operated in a commercial environment. This equipment generates, uses, and can radiate radio frequency energy and, if not installed and used in accordance with the instruction manual, may cause harmful interference to radio communications. Operation of this equipment in a residential area is likely to cause harmful interference in which case the user will be required to correct the interference at his own expense.

### 5.7 EC Declaration of Conformity

IXXAT Automation hereby declares  
that the product: iPCI-XC16/PCI

with the article numbers: 1.01.0047.33260  
1.01.0047.33110  
1.01.0047.33220

do comply with the EC directives 2004/108/EC.

Applied harmonized standards in particular:  
EN 55022:2006 + A1:2007  
EN 55024:1998 + A1:2001 + A2:2003

22.08.11, Dipl.-Ing. Christian Schlegel , Managing Director



IXXAT Automation GmbH  
Leibnizstrasse 15  
88250 Weingarten