

CAN Repeater

CAN-CR200, CAN-CR220, CAN-CR210/FO



IXXAT

Headquarter

IXXAT Automation GmbH
Leibnizstr. 15
D-88250 Weingarten

Tel.: +49 (0)7 51 / 5 61 46-0
Fax: +49 (0)7 51 / 5 61 46-29
Internet: www.ixxat.de
e-Mail: info@ixxat.de

US Sales Office

IXXAT Inc.
120 Bedford Center Road
USA-Bedford, NH 03110

Phone: +1-603-471-0800
Fax: +1-603-471-0880
Internet: www.ixxat.com
e-Mail: sales@ixxat.com

Support

In case of unsolvable problems with this product or other IXXAT products please contact IXXAT in written form by:

Fax: +49 (0)7 51 / 5 61 46-29
e-Mail: support@ixxat.de

For customers from the USA/Canada

Fax: +1-603-471-0880
e-Mail: techsupport@ixxat.com

Copyright

Duplication (copying, printing, microfilm or other forms) and the electronic distribution of this document is only allowed with explicit permission of IXXAT Automation GmbH. IXXAT Automation GmbH reserves the right to change technical data without prior announcement. The general business conditions and the regulations of the license agreement do apply. All rights are reserved.

1	Introduction	5
1.1	Overview	5
1.2	Features	5
1.3	Block diagram	6
2	Indicators and connections	7
2.1	Overview	7
2.2	Indicators	7
2.2.1	Power-LED	8
2.2.2	CAN LEDs	8
2.3	Connections	9
2.3.1	Power connector	9
2.3.2	CAN connector (Sub-D9M)	9
2.3.3	DIN rail bus and TBUS plug	10
2.4	CAN bus termination	10
3	Configuration	11
3.1	Configuration of the bus termination resistors	12
3.2	Configuration of the baudrate	12
3.3	Configuration of the lock time	13
4	Installation.....	14
4.1	Mounting a single CAN-Repeater.....	14
4.2	Mounting with DIN rail bus support.....	15
5	Support.....	17
6	Returning hardware	17
7	Appendix	18
7.1	Technical specifications.....	18
7.2	Accessories.....	19
7.2.1	CAN bus termination resistor	19
7.2.2	TBUS plug	19
7.2.3	Glass fiber cable	20
7.3	EMI Hints.....	20
7.4	Declaration of conformity.....	21
7.5	Note on disposal of used devices	22
7.6	FCC Compliance	22

1 Introduction

1.1 Overview

With the IXXAT CAN-Repeater CAN-CR200, CAN-CR210/FO or CAN-CR220 you purchased a high-quality electronic component developed and manufactured according to the latest technological standards.

The term "CAN-Repeater" is used in the following description to refer to the specific product. This manual is intended to familiarize you with the device. Please read this manual before beginning with the installation.

1.2 Features

- Power supply range +9 V ... +32 V DC
- CAN bus interface
 - CAN-CR200, CAN-CR220
 - two CAN bus interfaces according to ISO 11898-2, galvanically isolated
 - CAN-CR210/FO
 - one CAN bus interfaces according to ISO 11898-2, galvanically isolated
 - one CAN bus interface with FO modules (ST or SMA connectors)
 - CAN-CR200, CAN-CR210/FO
 - Additional CAN interface via DIN rail bus
 - Other IXXAT devices with the DIN rail bus can be connected via this bus to the CAN-Repeater.

1.3 Block diagram

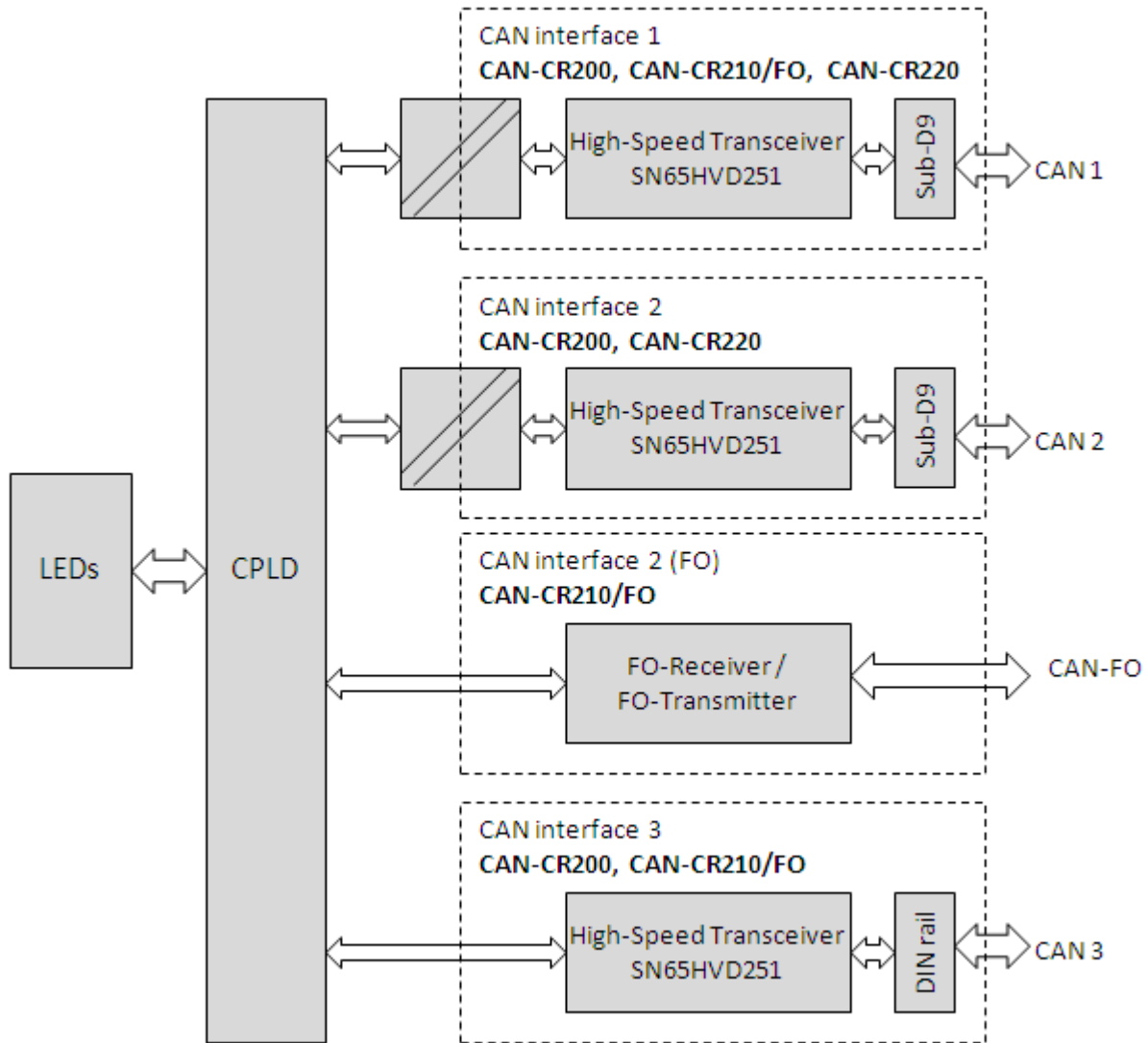

Picture 1-1 Block diagram of the CAN-Repeater

2 Indicators and connections

2.1 Overview

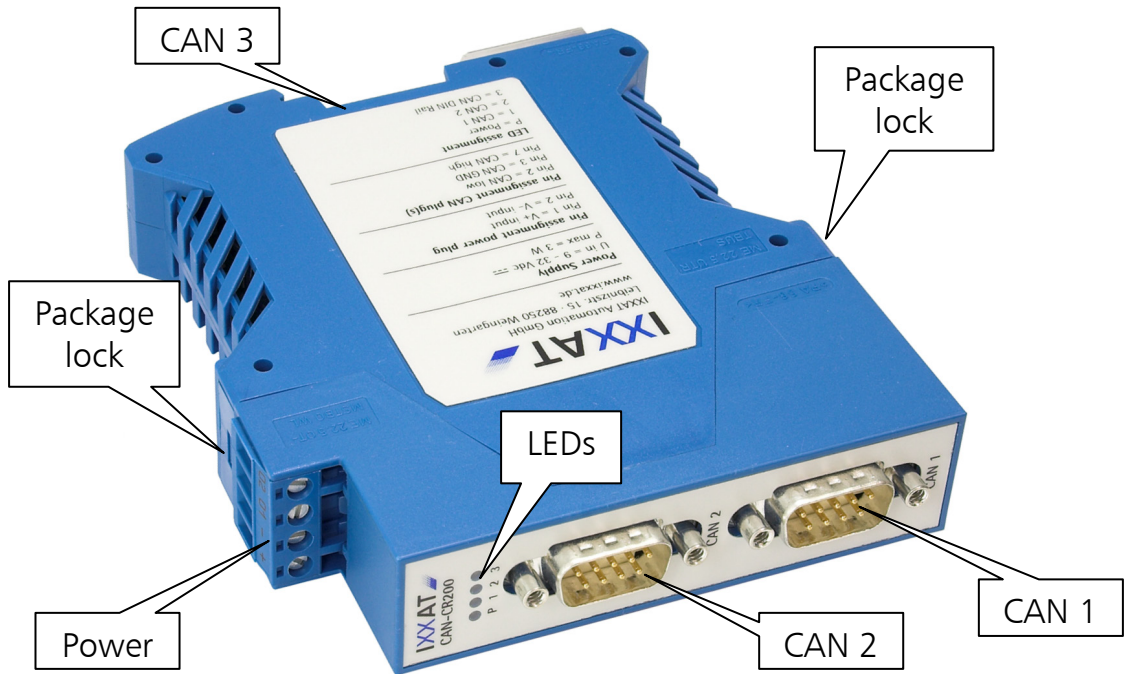

Picture 2-1 Connectors and indicators of the CAN-CR200

2.2 Indicators

The CAN-Repeater has a maximum of four LEDs. These LEDs show the communication status of the relevant interface or the device status.



Picture 2-2 LEDs of the CAN-Repeater

Indicators and connections

2.2.1 Power-LED

The Power LED **P** indicates the status of the power supply. If the LED is green, the power supply is working. If the LED is off, there is a problem with the power supply.

Flashing mode	Description	Causes/Hints
Off	No power	<ul style="list-style-type: none">• Device not connected to a power supply• Fuse of the device damaged• Internal power supply damaged
green	Power ok	<ul style="list-style-type: none">• Device fully functional
red	Device is resetted	<ul style="list-style-type: none">• After power-up the device is set into reset and the LED is red for the duration of the reset. The normal duration period is about 200 ms.• Power supply out of order, the internal voltage is below the necessary level.

Table 2-1 States of the Power-LED

2.2.2 CAN LEDs

The CAN LEDs **1,2** and **3** flashes on each received CAN message green, if there was no error detected.

If transmission errors (received bits are different to the transmitted bits) or a dominant-lock state are detected, the LEDs flashes red.

Flashing mode	Description	Causes/Hints
off	No CAN communication	<ul style="list-style-type: none">• No CAN communication• Device not connected to CAN
green / green blinking	CAN communication	<ul style="list-style-type: none">• With each CAN message the LED is triggered
red blinking	CAN communication, but errors	<ul style="list-style-type: none">• The received bits are not equal to the transmitted ones.
red	Dominant-lock	<ul style="list-style-type: none">• An external device applies a permanent dominant level to the CAN

Table 2-2 States of the CAN LEDs

2.3 Connections

2.3.1 Power connector

For the power connection of the CAN-Repeater, a screw terminal is used. For wiring, please ensure that the cross-sectional area of the cable is not less than 0.2mm². The maximum area is 2.5mm² for the connector.

Pin No.	Signal
1	+9 V bis +32 V DC
2	0 V
3	-
4	-

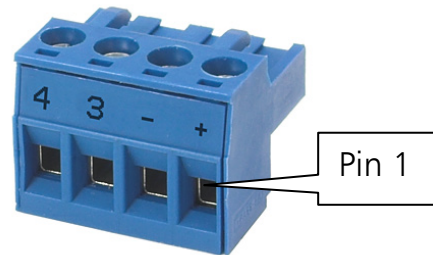

Table 2-3 Pin allocation of the power connector

The power connector is just plugged into the housing and can be removed with a screwdriver or similar tool.

2.3.2 CAN connector (Sub-D9M)

The CAN bus interfaces are according to ISO 11898-2. The signals of the CAN bus interfaces are connected to the Sub D-9 plugs (see Table 2-4).

Pin No. Sub D9	Signal
1	-
2	CAN-Low
3	CAN-GND
4	-
5	-
6	-
7	CAN-High
8	-
9	-

Table 2-4 Pin allocation of the CAN bus connector

The shield of the CAN connector is connected to the earth via a 10 nF capacitor. The earth of the device is automatically connected to the DIN rail after mounting

Indicators and connections

the device on the DIN rail. The ground of the CAN bus interface is connected to earth via a 1 M Ω resistor and a 10 nF capacitor.

For best noise immunity results, the shields of the CAN cables have to be grounded.

2.3.3 DIN rail bus and TBUS plug

The CAN-CR200 and CAN-CR210/FO have a DIN rail bus. With this interface the device can be connected to other CAN-CR200 or CAN-CR210/FO devices. Using this feature you have the possibility to realize a star topology with up to 240 CAN connections.

For the DIN rail bus so called TBUS plugs are necessary. This plugs were pressed into the DIN rail. More detailed information can be read in chapter 4.2

The signals of the DIN rail bus are described in Table 2-5

Pin No.	Signal
1	CAN-High
2	CAN-Low
3	GND
4	-
5	-

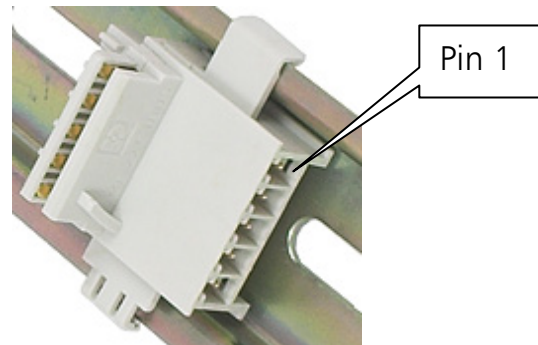

Table 2-5 Pin allocation of the DIN rail bus

2.4 CAN bus termination

The CAN-Repeater offers the possibility to add bus termination resistors to each CAN network connected to the device. This feature is realized with a DIP switch for each CAN channel. For more details please refer to chapter 3.1.

As an accessory a bus termination resistor is available as a feed through connector at IXXAT (ordering number 1.04.0075.03000).

3 Configuration

To operate the CAN-Repeater, no software installation is required.

Before you can use the CAN-Repeater the internal DIP switches S301, S302, CAN1, CAN2 and CAN3 has to be set according to the CAN network configuration.

In Picture 3-1 the positions of the DIP switches of the CAN-CR200 are shown. The DIP-switches of CAN-CR210/FO and CAN-CR220 are nearly at the same position.

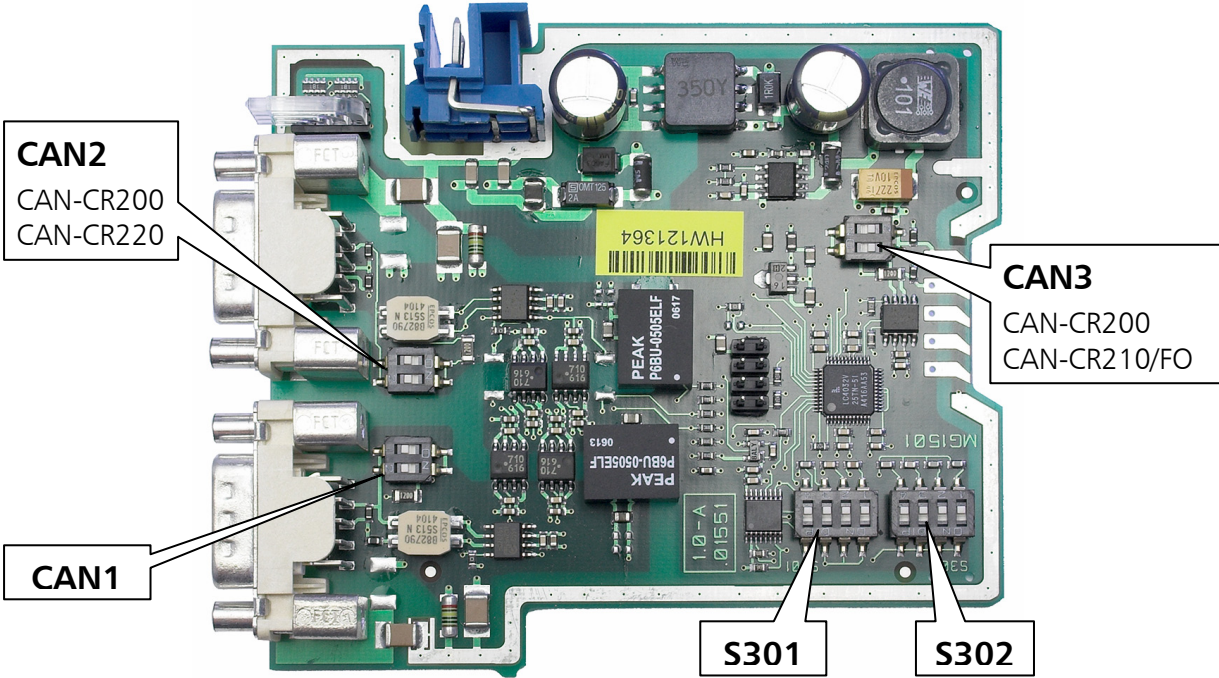

Picture 3-1 Position of the DIP switches

3.1 Configuration of the bus termination resistors

For each CAN circuit a bus termination resistor can be activated /deactivated by a DIP switch. Always both positions should be set to ON / OFF.

	CAN1	CAN2	CAN3
Default	OFF (deactivated)	OFF (deactivated)	ON (activated)

Table 3-1 Configuration of the bus termination resistors

The bus termination resistors should be activated if the CAN-Repeater is the first or the last device in the network. The termination resistor value of the total network should be about 60 Ohm (120 Ohm at both ends of the network).

If the bus termination is not correct, transmission problems could happen.

3.2 Configuration of the baudrate

With DIP switch **S301** the baudrate of the CAN network is defined. This setting is necessary, because the internal logic has to detect dominant-lock states (dominant level on CAN bus exceeds the maximum allowed duration).

S301-1	S301-2	S301-3	S301-4	Remark
ON	OFF	OFF	OFF	Baudrate between 5 kBd and 100 kBd
OFF	ON	OFF	OFF	Baudrate between 100 kBd and 500 kBd
OFF	OFF	ON	OFF	Baudrate equal or above 500 kBd (Default)

Table 3-2 Configuration of the baudrate

All combinations not listed in the table aren't allowed. If such a combination is set, malfunction of the CAN-Repeater could happen.

3.3 Configuration of the lock time

With DIP switch **S302** the lock time of the CAN-Repeater is defined. This time is used to avoid bit errors created by the device itself in a result of the signal propagation delay. Such an error could be a short dominant level inside of a recessive bit, which could cause bit errors at other CAN nodes (depending on the sampling point).

The setting of the lock time has to be done according to the baudrate and the capacitive load of the network.

	S302-1	S302-2	S302-3	S302-4	Lock time in ns (tolerance $\pm 10\%$)
	OFF	OFF	OFF	OFF	100
Default	OFF	OFF	OFF	ON	300
	OFF	OFF	ON	OFF	500
	OFF	OFF	ON	ON	800
	OFF	ON	OFF	OFF	1000
	OFF	ON	OFF	ON	1300
	OFF	ON	ON	OFF	1500
	OFF	ON	ON	ON	1800
	ON	OFF	OFF	OFF	2000
	ON	OFF	OFF	ON	2300
	ON	OFF	ON	OFF	2500
	ON	OFF	ON	ON	2800
	ON	ON	OFF	OFF	3000
	ON	ON	OFF	ON	3300
	ON	ON	ON	OFF	3500
	ON	ON	ON	ON	3800

Table 3-3 Configuration of the lock time

For reference values the following settings can be taken:

- for networks with less than 32 nodes the minimum lock time should be about 300 ns
- for networks between 32 and 64 nodes a minimum lock time of 500 ns should be used
- for networks with more the 64 nodes a minimum lock time of 1 μ s should be used, but with this setting the maximum baudrate is limited to 500 kBd.

4 Installation

To operate the CAN-Repeater, no software installation is required.

Before you use the CAN-Repeater following points have to be paid attention:

- configuration of the bus termination
- configuration of the baudrate
- configuration of the lock time

More detailed information to these points can be found in chapter 3.

4.1 Mounting a single CAN-Repeater

Prior to mounting the device it has to be assured, that the device is not connected to power.

In Picture 4-1 mounting of a CAN-CR220 is shown.

- 1 Put the upper groove on the DIN rail
- 2 Turn the device as shown to lock the lower mechanical interlock

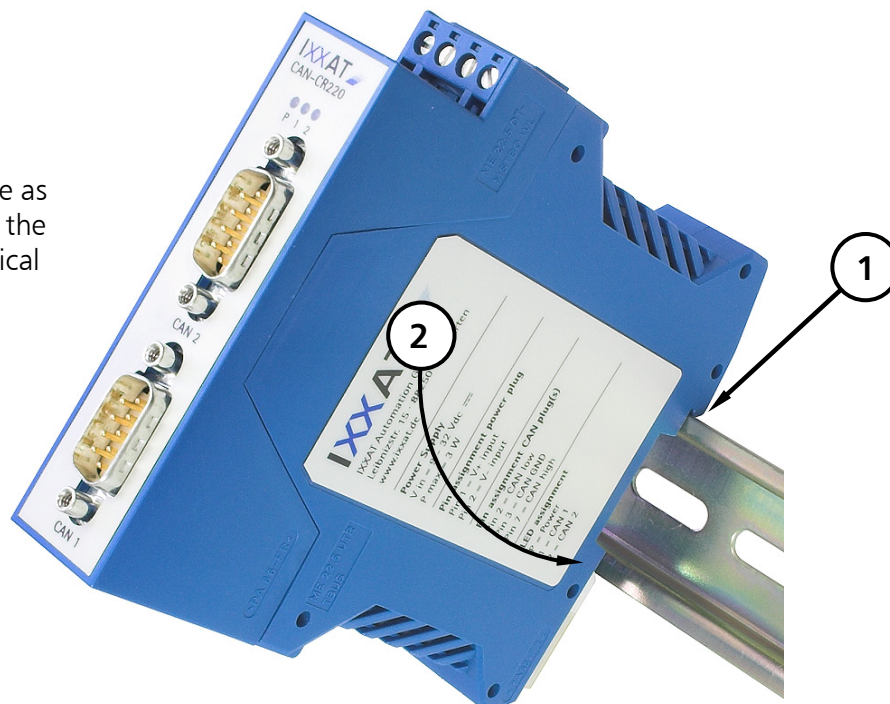

Picture 4-1 Mounting of an CAN-CR220

4.2 Mounting with DIN rail bus support

CAN-CR200 and CAN-CR210/FO support a DIN rail bus extension possibility. This feature gives you an easy possibility creating a star topology.

ATTENTION: The usage of the DIN rail bus is specific for IXXAT devices. If another DIN rail bus is used, this one must not be connected to the IXXAT DIN rail bus. If this is not considered, damages at the connected devices could happen!

Prior to the connection of a device to the DIN rail, the TBUS plug has to be mounted on the DIN rail. The orientation of the plug has to be adapted to the desired device installation position

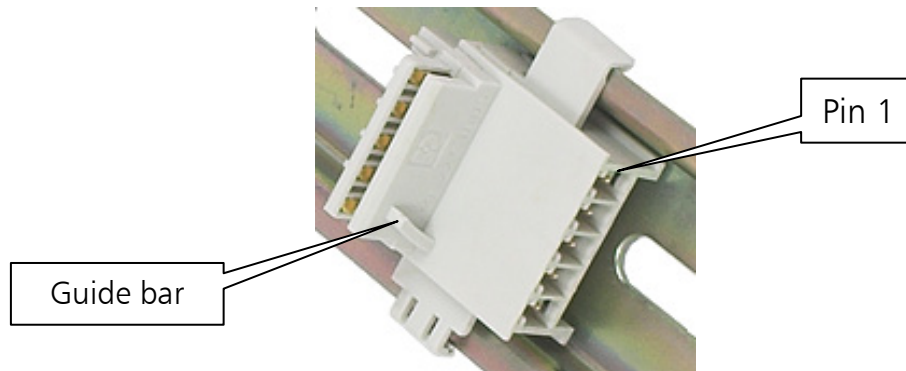

Picture 4-2 TBUS plug and DIN rail

If the guide bar is like in Picture 4-2 below the power connector of the CAN-Repeater is above.

Installation

The interconnection of two TBUS plugs can be achieved by mounting the plugs and afterwards were moved together, as shown in Picture 4-3.

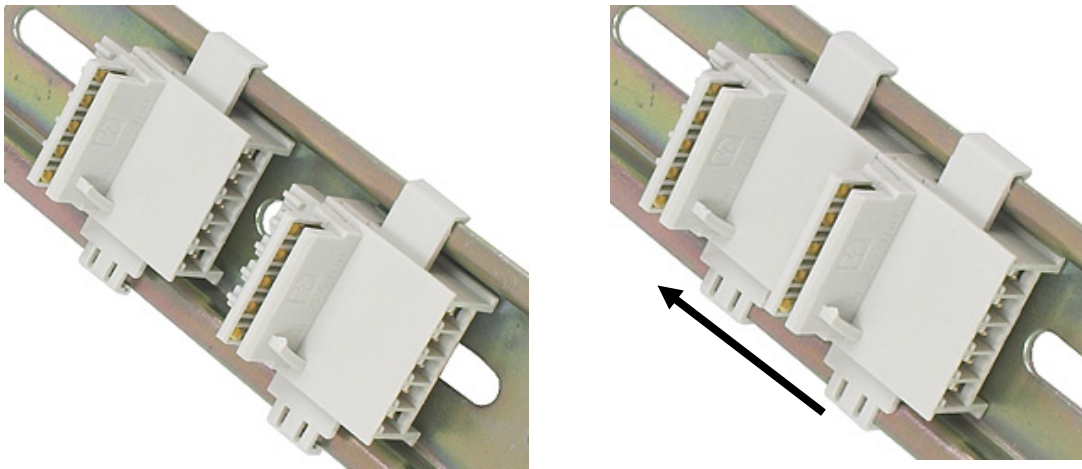

Picture 4-3 Mounting of TBUS plugs

Now the CAN-Repeater CAN-CR200 and/or CAN-CR210/FO can be mounted.

The package of the CAN-CR200 and CAN-CR210/FO has an opening for the TBUS plug in the area of the DIN rail, see Picture 4-4 . While the devices are attached to the DIN rail, a correct mounting to the TBUS plug has to be observed. The guide bar of the plug has to mate into the slot in the package.

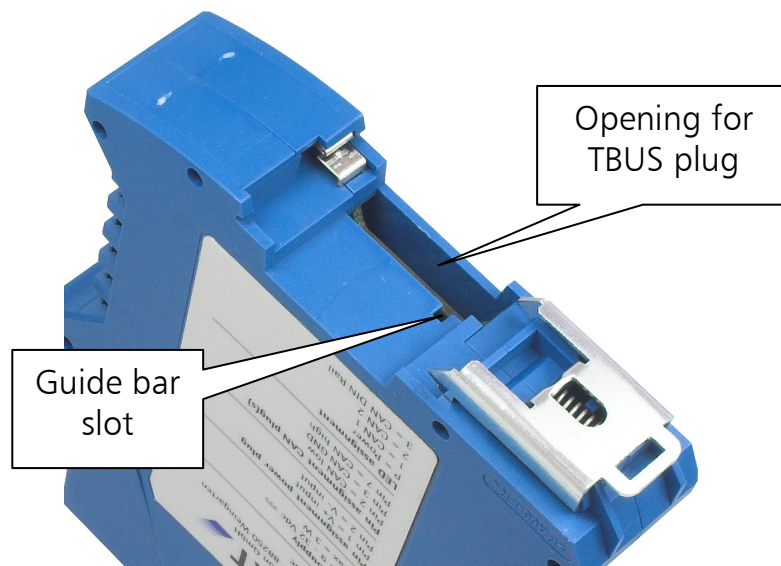

Picture 4-4 Opening for TBUS plug

Prior to mounting the device it has to be assured, that the device is not connected to power.



Picture 4-5 Mounting an CAN-CR200

5 Support

For more information on our products, FAQ lists and installation tips, please refer to the support area on our homepage (<http://www.ixxat.com>). There you will also find information on current product versions and available updates

6 Returning hardware

If it is necessary to return hardware to us, please download the relevant RMA form from our homepage and follow the instructions on this form.

7 Appendix

7.1 Technical specifications

Power supply:	+9 V ... +32 V DC		
Power consumption at 24 V:		typical	maximum
	CAN-CR200	41 mA	100 mA
	CAN-CR220	41 mA	100 mA
	CAN-CR210/FO	62 mA	100 mA

CAN Transceiver: Texas Instruments SN65HVD251

Max. number of CAN bus nodes: 120

CAN bus termination resistor: 120 Ohm switchable via DIP switch

CAN propagation delay (typical):

CAN-CR200	210 ns
CAN-CR220	175 ns
CAN-CR210/FO	120 ns

CAN baudrates: 5 kBaud – 888 kBaud

Housing material: Polyamid

Dimensions (L x B x H) in mm: 114.5 x 99 x 22.5

Weight: ca. 300 g

Protection class: IP30

Operating temperature range: -20 °C - +70 °C

Storage temperature range: -40 °C - +85 °C

Relative humidity: 10 - 95 %, non-condensing

Galvanic isolation:

Product	order number	galvanic isolation
CAN-CR200	1.01.0067.44010	500 V AC / 1 min.
CAN-CR220	1.01.0067.44400	4 kV DC / 1 sec, 2.50 kV AC / 1 min
	1.01.0067.44300	3 kV AC / 3 min, 3.75 kV AC / 1 min
CAN-CR210/FO	1.01.0068.4x010	500 V AC / 1 min

EMC-test according to: DIN EN 55022:1998 + A1:2000 + A2:2003
(Limit class A)

FCC Rules 47 CFR Part 15 – Subpart B

Alternative IEC/CISPR22:1997 + A1:2000
+ A2:2002 (Limit class A)

Environmental directive: RoHS, WEEE, Directive (2002/95/EC)

7.2 Accessories

7.2.1 CAN bus termination resistor

IXXAT offers a bus terminal resistor as a feed through connector (order number 1.04.0075.03000).

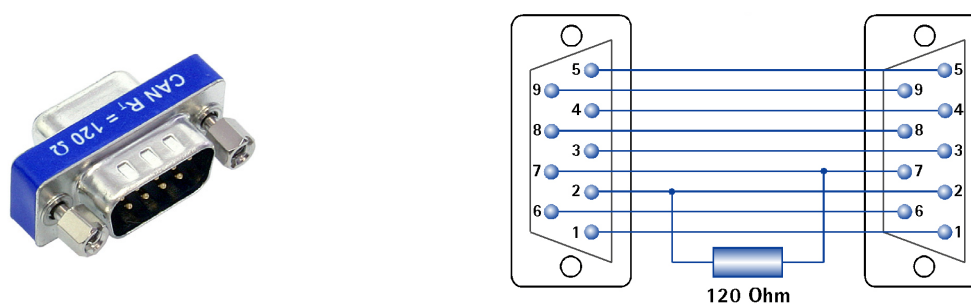

Picture 7-1 CAN bus terminal resistor

7.2.2 TBUS plug

Interconnection with other IXXAT devices supporting the DIN rail bus (e.g. CAN-CR200 and/or CAN-CR210/FO) is possible by using the TBUS plug offered by IXXAT (order number 1.04.0073.00000).

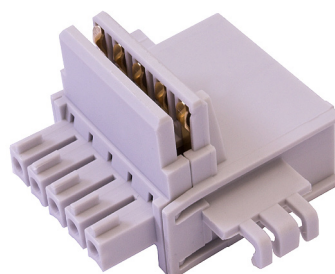

Picture 7-2 TBUS plug

7.2.3 Glass fiber cable

IXXAT offers cable assemblies for interconnection of two CAN-CR210/FO.



Type	length /m	order number	Picture
FSMA	2	1.04.0003.01012	
	5	1.04.0003.01015	
ST	2	1.04.0003.01022	
	5	1.04.0003.01025	

Table 7-1 Glass fiber cable

7.3 EMI Hints

The CAN-Repeater is a Class A device. This means, that it is tested and designed for industrial use and complies to this requirements.

If the device is used in an office or living area, in extreme cases radio interferences could happen.

To guarantee a correct function of the CAN-Repeater some EMI points have to be paid attention:

- the DIN rail have to be connected to earth
- the CAN cable has to be shielded
- the shield of the CAN cable has to be connected to the Sub-D9 and has to be connected on the other device.

If there are still problems while the CAN-Repeater is switched on, the distance between a source of interference (eg. motors, frequency inverter) or a drain of interference and the device should be enlarged.

7.4 Declaration of conformity

IXXAT Automation hereby declares that the products:

	order number
CAN-CR200	1.01.0067.44010
CAN-CR210/FO	1.01.0068.45010
	1.01.0068.46010
CAN-CR220	1.01.0067.44400
	1.01.0067.44300

do comply with the EC directives 2004/108/EC.

Applied harmonized standards in particular:

EN 55022:2006 + A1:2007

EN 55024:1998 + A1:2001 + A2:2003

22.08.2011, Dipl.-Ing. Christian Schlegel, Managing Director



IXXAT Automation GmbH
Leibnizstr. 15
88250 Weingarten

7.5 Note on disposal of used devices

This product is subject to the ElektroG (electrical and electronic equipment act) and is to be disposed of in accordance with this act.

The Terms of Sale and their supplements as well as further information on the disposal of used devices can be downloaded from www.ixxat.com.

7.6 FCC Compliance

Declaration of conformity

This device complies with Part 15 of the FCC Rules. Operation is subject to the following two conditions:

- this device may not cause harmful interference, and
- this device must accept any interference received, including interference that may cause undesired operation.

Class A digital device instructions

Note: This equipment has been tested and found to comply with the limits for a Class A digital device, pursuant to Part 15 of the FCC Rules. These limits are designed to provide reasonable protection against harmful interference when the equipment is operated in a commercial environment. This equipment generates, uses and can radiate radio frequency energy and, if not installed and used in accordance with the instruction manual, may cause harmful interference to radio communications. Operation of this equipment in a residential area is likely to cause harmful interference, in which case the user will be required to correct the interference at his own expense.