

Total Solution of Industrial Controller

Feature

- Industrial field applicationBuilding automation
 - PLC controller
 - Medical instruments
- Plastic extruding chassis with the easily accessible HDD.
- Power/Lan/Sys status indicator on the front.
- Easy to connecting with I/O interface along the side edge.
- Highest system performance with 1MB SRAM data exchange.
- Stable 8-wire resistor touch screen sensor and controller.
- Reliable system design utilizing top-grade solid-state capacitor on the CPU card.
- Integrated high brightness and contrast ratio LCD display



ATP-PLC-1210



<http://www.atiosys.com>
<http://www.atiosys.com>

ATP-PLC-1210

<http://www.atiosys.com>

Specifications

- Display Type : 12.1 " TFT LCD (super brightness)with external VGA port
- Resolution : 800 X 600
- CPU : VIA CPU up to 1G /optional fan-less type CPU .
- Memory : 256MB SDRAM, up to 512MB
- Storage device : 2.5 inches HDD (option, 2.5 flash disk) easily accessible
- Data switching : up to 1MB SRAM for system data
- Extension bus : PC 104 plus extension bus
- Ethernet : Dual Lan 10 / 100 Base-T LAN
- Serial Port : 1 RS-232/422/485 D-sub 25 pin & 1RS-232 Port
- Operation Temperature : 0~50°C
- Vibration : 5~500 Hz 1G RMS Random Vibration
- Power Supply : AC90 ~ 264V, 47 ~ 63Hz
- Contrast Ratio : 300
- Brightness : 300 candle light
- Backlight MTBF : 50,000 hrs
- Weight : 0.8 Kg W/O package

Power Supply

- Output Rating : 100W max
- Input : 90-264VAC / 47~63Hz
- Output : 5V/12V/-12V/-5V
- EMI / EMS : Meets FCC / CE , full compliance with the LVD
- Safety : Meets UL / CSA

Touch Screen

- Type : 8-Wire Analog Resistive
- Resolution : 800 x 600 or higher
- Interface : RS-232
- Light Transmission : 76%
- Durability : 30 Million touches per one point(pixel)
- Sheet resistance : 220 + 30%Ω / Square
- Insulation resistance : >20MΩ @ 25VDC

Specifications subject to change without notice.

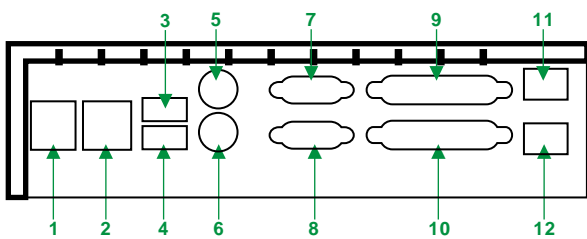

- | | |
|-------------|------------------|
| 1. LAN1 | 7. VGA |
| 2. LAN2 | 8. COM1 |
| 3. USB1 | 9. D-25 COM3 |
| 4. USB2 | 10. D-25 Printer |
| 5. Mouse | 11. Speaker |
| 6. Keyboard | 12. Micro-phone |

Dimension

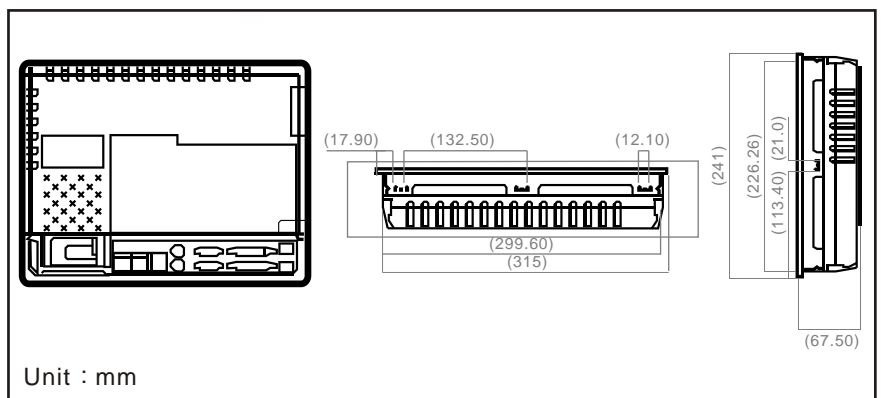

Unit : mm



Headquarter

ATIO SYSTEM Inc.
8F-10, No. 351, Sec. 2, Chung Shan Rd., Chung Ho City, Taipei 235, Taiwan
Tel: 886-2-3234-3089
Fax: 886-2-2226-9622
E-Mail: atio@atio

North American Branch
21540 PrairieStreet,
UnitA,Chatsworth,CA 91311,
U.S.A.
Tel: 1-818-407-4965
Fax: 1-818-407-4066

Neotek System, Inc. (Shenzhen)
11G, No. 59, Xinwen Road, Futian fortune Shenmao trading Centre, Shenzhen, China 518034
Tel: 86-755-8294-9074
Fax: 86-755-8294-9122

Distribución: **ER-SOFT, S.A.** Email: er@er-soft.com, Tel: +34 916 408 408