



- Ideal for OEM's looking to incorporate a sealed, robust connection into their field device
- Category 5 compliant
- Short depths for space constrained applications
- Achieves IEC IP67 rated seal when mated with an RJ-Lnxx cordset – but also compatible with commercial RJ 45 patch cords

*As Ethernet-enabled factory floor device demand increases, so does the need for a sealed, robust connection that can be easily incorporated into the*



*device. The RJ-Lnxx® ENPR1FF5 receptacle allows a simple solder attachment to the primary PCB in the exact same manner as a commercial grade jack would be incorporated. The receptacle is also designed so that it can be inserted through the housing of the device after being attached to the PCB.*

## Specifications

O-RING MATERIAL:	VITON
INSERT MATERIAL:	ACRYLONITRILE-BUTADIENE-STYRENE (ABS)
OVERMOLD MATERIAL:	POLYURETHANE
COUPLING NUT MATERIAL:	ACRYLONITRILE-BUTADIENE-STYRENE (ABS)
SHELL MATERIAL:	ACRYLONITRILE-BUTADIENE-STYRENE (ABS)
KNOCKOUT HOLE:	1.063
THREAD SIZE:	UNC 1" - 14
PANEL THICKNESS:	.125" MAXIMUM WITH GASKET, .187" MAXIMUM WITHOUT GASKET, .062" MINIMUM
OPERATING TEMPERATURE:	-20° TO 80° C
RETURN LOSS:	5 dB @ 100 MHZ
ENVIRONMENTAL RATING:	IEC IP67
TIA/EIA RATING:	CATEGORY 5 COMPLIANT
<b>RJ-45 JACK</b>	
PLATING:	50 MICRON OF GOLD OVER 100 MICRONS OF NICKEL
CURRENT RATING:	1.5 A
VOLTAGE RATING:	125V DC

## RECEPTACLE DIMENSIONS

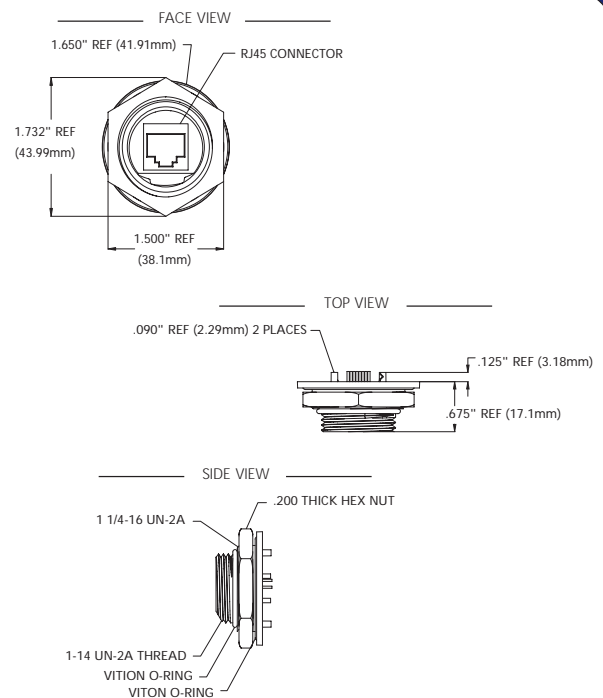

PART NUMBER	DESCRIPTION
ENPR1FF5	DIRECT PC BOARD MOUNT RECEPTACLE