

## xPI-Link

>>> **100% Simatic S7-PLC compatible** <<<

For easy communication  
with  
**Siemens Simatic S7-200 ®,**  
**Siemens Simatic S7-300 ®,**  
**Siemens Simatic S7-400 ®,**  
via  
Ethernet TCP/P / Internet.

Professional **Profibus / MPI / PPI** connection  
for **Data access** or  
**Programming access** to  
Siemens Simatic S7-200 / 300 / 400

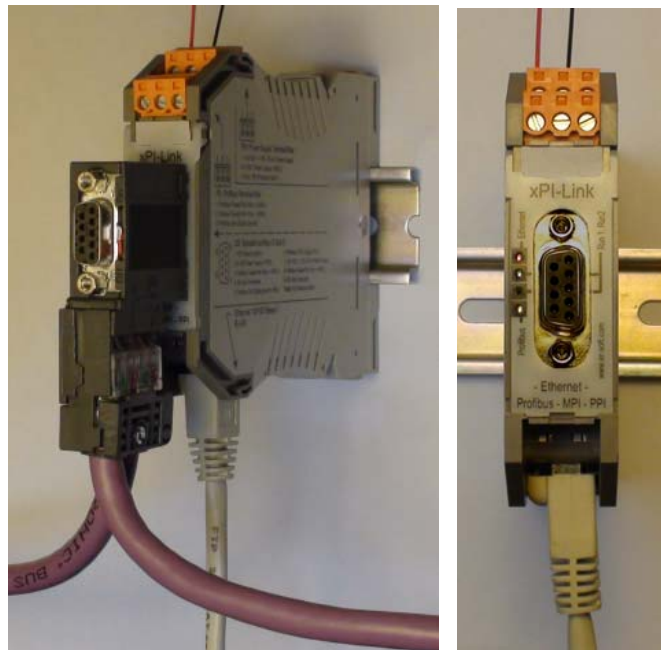

**xPI-Link**  
Professional  
**Ethernet to Profibus / MPI / PPI Gateway**

### **xPI-Link overall Features:**

- The xPI-Link is a highly industrial rated gateway device for 35 mm DIN-Rail mount.
- The xPI-Link design is based on a robust single-PCB design (Printed Circuit Board).
- The xPI-Link design includes only the required interface connectors, which are all industry rated.
- The xPI-Link is flexible in use: 2 Profibus connection options: Simple or Professional Profibus Cabling.
- The xPI-Link is flexible in use: 2 Power Supply options: External 24 +/-10% Vdc or from MPI Connector.
- The xPI-Link electronic components are all of extended temperature range: -40 to +85 deg Celsius, which enables the xPI-Link to work in the temperature range: -40 to +70 deg Celsius.
- IP-20 protection level.
- Environmental attractive RoHS directive compliant design with low power consumption.
- Inflammability: The xPI-Link Plastic enclosure and PCB comply to UL94-V0 inflammability norm.

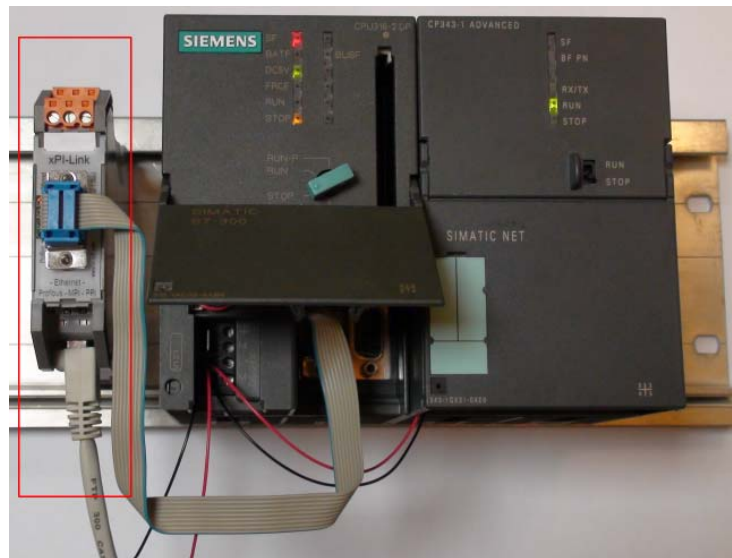

### xPI-Link

Easy Plug & Play (flat-cable)  
**Ethernet to Profibus / MPI / PPI Connection.**

As easy as shown:

xPI-Link powered from the S7 PLC or by extern 24 Vdc.

### Installation of the xPI-Link:

1. Overview & General Information.
2. Mechanical Installation.
3. Power supply cabling options.
4. PW: Power Supply screw terminal connector and cabling.
5. PB: Profibus screw terminal connector.
6. DB: Profibus / MPI / PPI Sub-D9 connector.
7. RJ-45 Ethernet connector and cabling.
8. Power-up and use the installation.
9. LED indicators.
10. PB: Profibus screw terminal cabling and correct Profibus termination.
11. DB: Profibus / MPI / PPI Sub-D9 cabling and correct Profibus termination.
12. Specifications.
13. Configuration by embedded HTTP Web server.

#### 1: Overview & General Information.

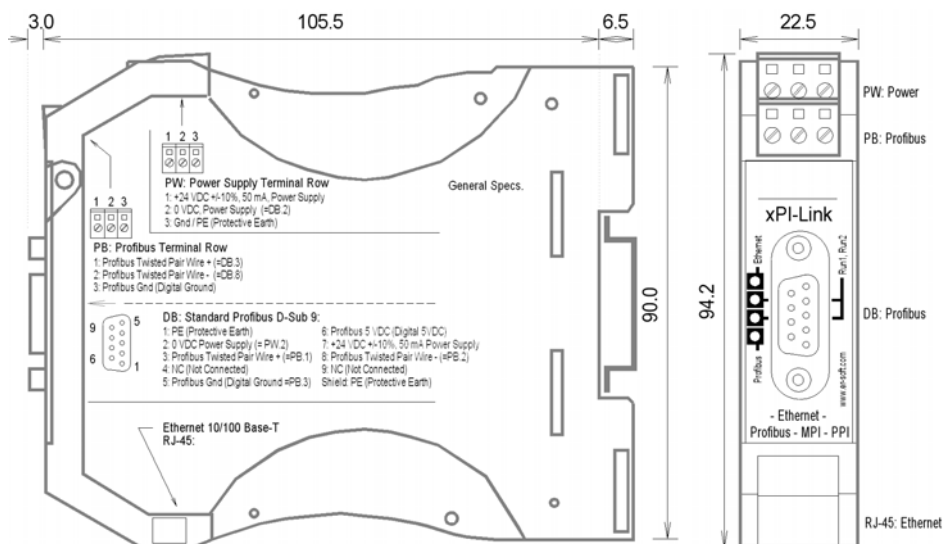

## **2: Mechanical Installation.**

Mount the xPI-Link vertically so it allows for air cooling by natural convection (as illustrated on the front page) on a horizontally mounted 35 mm DIN-Rail.

If the air cooling is obstructed, the high limit of the working temperature range may be considerably reduced.

## **3: Cabling options and Power supply options.**

- The xPI-Link is delivered with a Ribbon Cable of 0.5 meter with a Sub-D 9-pin male connector at each end. The Ribbon Cable allows direct connection of the xPI-Link to a Simatic S7-Nnn PLC. This includes the Profibus / MPI / PPI communication line and the 24 Vdc Power Supply of the xPI-Link from the Simatic S7-Nnn PLC Power Supply. This solution is valid for short haul communication only (0.5 m).
- If a long haul Profibus / MPI / PPI communication line is required, the Simatic S7-Nnn PLC or PLCs are most probably distributed over the local area. In this case use professional Profibus Cable and Profibus Cable connectors with Termination option for the Bus end points (use correct transmission line termination in order to avoid signal reflections, that act as noise in the transmission line). In this case apply 24 Vdc Power Supply directly to the xPI-Link Power Supply terminals.

## **4: PW: Power Supply screw terminal connector and cabling.**

Based on the decision about cabling option (see above), the Power Supply options must be given.

However, if the Ribbon Cable connection is the chosen option, the application of external 24 Vdc Power Supply directly to the xPI-Link Power Supply terminals is still an option. Optionally cut the Ribbon Cable wire between the 2 Sub-D 9-pin male connectors terminal no 7

Note that the xPI-Link electronics is supplied from:

- PW: Power Supply terminal no 1, or
- Profibus / MPI / PPI communication Sub-D 9-pin female connector terminal no 7.

Special notes about the xPI-Link Power Supply:

- Both supply terminals go to the anodes of reverse polarity protection Diodes.
- The cathodes of the two reverse polarity protection Diodes are connected to the xPI-Link electronics 24 Vdc supply side, resulting in Power Supply from one or the other Power Supply terminal.

## **PW: Power Supply screw terminal row:**

- 1: +24 VDC, 50 mA, Power Supply
- 2: 0 VDC, Power Supply (=DB.2)
- 3: Gnd / PE (Protective Earth)

## **5: PB: Profibus / MPI / PPI terminal row:**

- 1: Profibus Twisted Pair Wire + (=DB.3)
- 2: Profibus Twisted Pair Wire - (=DB.8)
- 3: Profibus Gnd (Digital Ground)

## **6: DB: Profibus / MPI / PPI Sub-D 9-pin female connector (standard):**

- 1: PE (Protective Earth)
  - 2: 0 VDC Power Supply (= PW.2)
  - 3: Profibus Twisted Pair Wire + (=PB.1)
  - 4: NC (Not Connected)
  - 5: Profibus Gnd (Digital Ground =PB.3)
  - 6: Profibus 5 VDC (Digital 5VDC)
  - 7: +24 VDC, 50 mA Power Supply
  - 8: Profibus Twisted Pair Wire - (=PB.2)
  - 9: NC (Not Connected)
- Shield: PE (Protective Earth)

## **7: RJ-45 Ethernet cabling.**

Standard CAT5 Ethernet cabling terminated with RJ-45 plugs.

The xPI-Link has a female RJ-45 with auto sense 10/100 base-T.

The xPI-Link connects to Ethernet Switch or HUB using a straight cable.

The xPI-Link connects directly to a PC or other Computer Equipment using a cross-over cable.

### 8: Power-up and use the installation.

See LED Indicators section below for detailed indication of the xPI-Link the operation.

### 9: LED Indicators.

4 Light Emitting Diodes (LEDs) will indicate the operation of the xPI-Link.

Table 1 below shows the normal operation of the xPI-Link.

Table 2 below shows the Start-up phase of the xPI-Link. This information can be valuable in order to determine the cause of malfunction, if the xPI-Link does not enter into normal operation.

| <b>Table 1: xPI-Link Normal Operation.</b> |  |                          |                          |                              |   |
|--|--|--------------------------|--------------------------|------------------------------|---|
| <b>Note</b>                                | <b>Profibus<br/>(Red)</b>                                | <b>Run1<br/>(Green1)</b> | <b>Run2<br/>(Green2)</b> | <b>Ethernet<br/>(Yellow)</b> | <b>Indicates:</b>                       |
|  |  | <b>Blink</b>             | <b>/Blink</b>            |                              | xPI-Link powered & CPU working properly |
|  |  | <b>Fix On/Off</b>        | <b>Fix On/Off</b>        |                              | CPU failure if Blink stops              |
|  | <b>Off</b>   |                          |                          |                              | No Profibus activity in xPI-Link        |
| 1  | <b>Dimmed</b>  |                          |                          |                              | Profibus activity in xPI-Link           |
|  | <b>Fix On</b>  |                          |                          |                              | Profibus failure in xPI-Link            |
|  |  |                          |                          | <b>Off</b>                   | No Ethernet connection                  |
|  |  |                          |                          | <b>On</b>                    | Ethernet carrier detected               |
|  |  |                          |                          | <b>Blink</b>                 | Indicates Ethernet activity             |
| <b>Notes:</b>                              |  |                          |                          |                              |   |
| 1  | Dimmed means very fast blinking so it appears as dimmed. |                          |                          |                              |   |

| <b>Table 2: xPI-Link Start-up Phase.</b> |   |                          |                          |                              |  |
|--|---|--------------------------|--------------------------|------------------------------|--|
| <b>Note</b>                              | <b>Profibus<br/>(Red)</b>   | <b>Run1<br/>(Green1)</b> | <b>Run2<br/>(Green2)</b> | <b>Ethernet<br/>(Yellow)</b> | <b>Indicates:</b>  |
| 2  | Off   | Off                      | Off                      | Off                          | No power, bootstrap checksum failed                        |
| 2  | Off   | Off                      | Off                      | On                           | Bootstrap checksum failed                                  |
| 2  | On  | Off                      | Off                      |                              | RAM test in progress, remains in this state if test failed |
| 2  | Off   | On                       | Off                      |                              | Serial port test   |
| 1  | On  | Blink                    | Off                      |                              | Serial port program load in progress                       |
| 1  | On  | On                       | Off                      |                              | Serial port program load failed                            |
| 3  | Blink   | On                       | Off                      |                              | Serial flash load in progress                              |
| 1  | Blink   | Blink                    | Off                      |                              | Serial flash load failed                                   |
| 1  | Off   | Blink                    | Off                      |                              | xPI-Link firmware invalid                                  |
| <b>Notes:</b>                            |   |                          |                          |                              |  |
| 1  | Severe Error: Should never be seen in a correctly working xPI-Link. |                          |                          |                              |  |
| 2  | Should last less than 1 second in a correctly working xPI-Link.     |                          |                          |                              |  |
| 3  | Should last less than 9 second in a correctly working xPI-Link.     |                          |                          |                              |  |

**10: PB: Profibus screw terminal cabling and correct Profibus termination.**

**11: DB: Profibus / MPI / PPI Sub-D9 cabling and correct Profibus termination.**

Profibus is sensitive to correct Profibus Cable termination while the communication speed is high and the bus cable is long.

The problem is the limited speed of the transmission of light (or electromagnetic waves in a medium) and possible reflections due to transmission-line discontinuities.

- The Profibus transmission-line is a shielded copper twisted pair transmission-line.
- A transmission-line has a characteristic impedance which is pure resistive.
- Transmission-line continuity means that each cable cut over shall make any of the cable ends look into a pure resistive value equal to the characteristic cable impedance.
- Transmission-line discontinuity means that each cable cut over will have some of the cable ends look into something that is not a pure resistive value equal to the characteristic cable impedance. In all these points we speak about Transmission-line discontinuity. Transmission-line discontinuity cause reflections in the same degree as the transmission-line discontinuity in the point.
- Signal reflections has the character of electrical noise, and it cause undesired signal attenuation in the transmission line due to the lost signal power in the reflections.
- Let up put some real numbers on it: The medium in this case is copper. The speed of electromagnetic waves in a copper cable is 0.2 meter / nanosecond ( $10^{-9}$  s). If Profibus communicates 12 Mbit/s, which means that each bit has a time of 83 nanoseconds (= 16.6 m in bit length in the bus cable). In other words: For each 16.6 m down the bus cable, the signal switches to either the next bit or the previous bit transmitted in the profibus PDU (Protocol Data Unit).
- Profibus shielded copper twisted pair uses a Biased Termination Resistor network like the one shown in the illustration below. Exactly this Termination Resistor network is found in all professional Profibus Cable Connectors with Terminator Switch.

Profibus DB9 Quality Connectors:



Profibus DB9 Connector Pin designations:

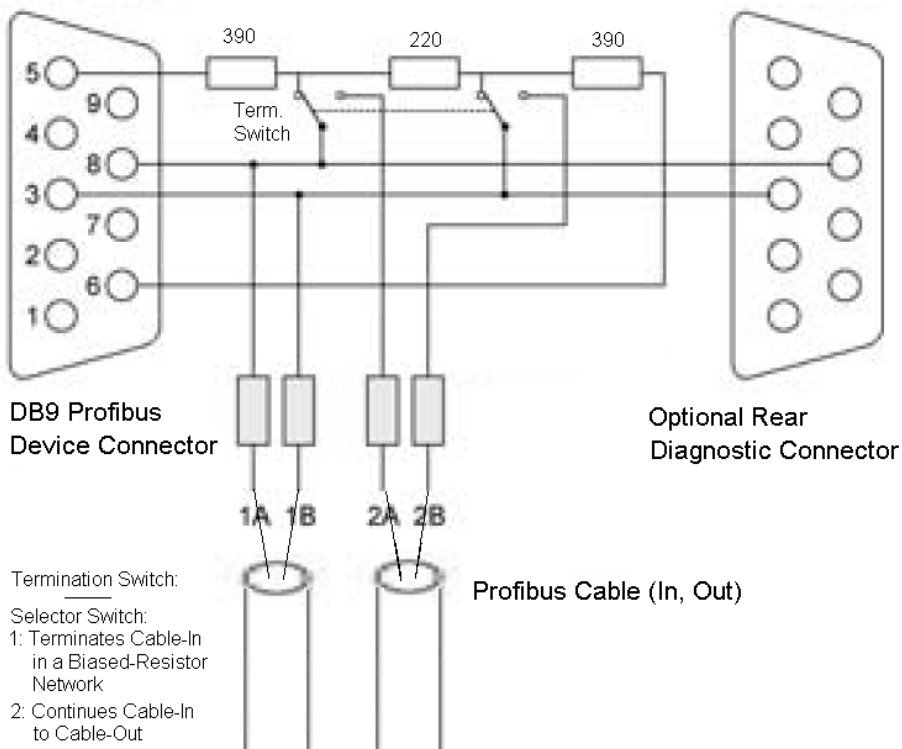

- Professional Profibus Cable Connectors with **Terminator Switch** use 3 resistors in series: 390, 220 and 390 ohms. The first resistor is connected to 5 VDC and the last to 0 VDC. This results in a bias of 1.1 VDC on the twisted pair wires and a termination resistance of approximately 170 Ohms, if the terminator switch is ON (Closed).
- The Profibus Cable has the Characteristic Impedance of 150 Ohms +/- 15 Ohms according to the Profibus specifications.
- Important Note: The terminator switch shall only be ON (Closed) at the bus ends where only one Profibus cable end is inserted into the Profibus Cable Connector.
- Note that the xPI-Link Profibus connectors PB and DB both presents the same terminals + and -. This allows use of both connectors. **The termination rules remains always the same. These are physical rules, independent of the name of the applied network or fieldbus.**
  - Connect two cable ends and no termination resistor network, or
  - Connect one cable end and one termination resistor network.
  - The Profibus screw terminals do not directly allow for Biased termination, so only a unbiased termination might be possible.

## 12: Specifications.

|                                    |  |
|------------------------------------|--|
| <b>Ethernet:</b>                   |  |
| Interfase:                         | RJ45, 10 / 100 Base-TX   |
| Simultaneous TCP Connections:      | Up to 4  |
| <b>Profibus:</b>                   |  |
| Transmission speed:                | Optical Isolates following the EN 50170 Profibus Specification<br>9600 Baud to 12 M. Baud. |
| Interface type:                    | RS-485 in standard Sub-D 9 pin and in Terminal Row.  |
| Simultaneous Profibus Connections: | Up to 6  |
| <b>General:</b>                    |  |
| Power Supply:                      | +24 V / 50 mA  |
| Operation Temperature:             | -20 °C - +70 °C  |
| Protection rate:                   | IP 20  |
| Dimensions:                        | (L x W x H) 65 x 48 x 16 mm  |
| Weight:                            | 140 g  |

13: Configuration by embedded HTTP Web server.

|   |   |                   |  |
|---|---|-------------------|--|
| <b>xPI-Link</b> by:   | <b>FIELDBUS ELECTRONICS</b><br>...automation interconnect.  |                   |  |
| Worldwide distribution:   | <b>ER-Soft, S.A.</b><br><a href="http://www.er-soft.com">www.er-soft.com</a> , <a href="mailto:info@er-soft.com">info@er-soft.com</a> |                   |  |
| Table of Pages:   | <b>Version information:</b>   |                   |  |
| <a href="#">Home</a><br><a href="#">Statistics</a><br><a href="#">Help on configuration</a><br><a href="#">TCP/IP Configuration</a><br><a href="#">Profibus/MPI Configuration</a><br><a href="#">Advanced Profibus Configuration</a><br><a href="#">Change password</a> | <b>Information about hardware:</b>  |                   |  |
|   | Hardware Type ID:   | 200806240001      |  |
|   | Hardware Version ID:  | 200807070004      |  |
|   | Software Type ID:   | 200808120001      |  |
|   | Serial ID:  | 200808230025      |  |
|   | Serial Number:  | 271025            |  |
|   | MAC:  | 46:08:7d:03:e9:fc |  |
|   | Executable Software(s):   | 1 2 0 0 0 0 0 0 0 |  |
|   | Software executable by mask:  | 80000000          |  |
|   | <b>Information about firmware:</b>  |                   |  |
|   | Executable software number:   | 1                 |  |
|   | Software needs execution mask:  | 00000001          |  |
|   | Software ID:  | 200808250004      |  |
|   | Software Version ID:  | 200809110005      |  |
|   | <b>Information provided by loader:</b>  |                   |  |
| Copies of firmware at ROM page:   | 100 600   |                   |  |
| Firmware loaded from page:  | 100   |                   |  |

|   |   |                                  |                                  |                                  |                                 |
|---|---|----------------------------------|----------------------------------|----------------------------------|---------------------------------|
| <b>xPI-Link</b> by:   | <b>FIELDBUS ELECTRONICS</b><br>...automation interconnect.  |                                  |                                  |                                  |                                 |
| Worldwide distribution:   | <b>ER-Soft, S.A.</b><br><a href="http://www.er-soft.com">www.er-soft.com</a> , <a href="mailto:info@er-soft.com">info@er-soft.com</a> |                                  |                                  |                                  |                                 |
| Table of Pages:   | <b>TCP/IP Configuration:</b>  |                                  |                                  |                                  |                                 |
| <a href="#">Home</a><br><a href="#">Statistics</a><br><a href="#">Help on configuration</a><br><a href="#">TCP/IP Configuration</a><br><a href="#">Profibus/MPI Configuration</a><br><a href="#">Advanced Profibus Configuration</a><br><a href="#">Change password</a> | <b>IP Address:</b>  | <input type="text" value="192"/> | <input type="text" value="168"/> | <input type="text" value="0"/>   | <input type="text" value="80"/> |
|   | <b>Net mask:</b>  | <input type="text" value="255"/> | <input type="text" value="255"/> | <input type="text" value="255"/> | <input type="text" value="0"/>  |
|   | <b>Gateway address:</b>   | <input type="text" value="192"/> | <input type="text" value="168"/> | <input type="text" value="0"/>   | <input type="text" value="1"/>  |
|   | <input type="button" value="Configure IP"/>   |                                  |                                  |                                  |                                 |
|   |   |                                  |                                  |                                  |                                 |
|   |   |                                  |                                  |                                  |                                 |

|   |  |
|---|--|
| <b>xPI-Link</b> by:   | <b>FIELDBUS ELECTRONICS</b><br>...automation interconnect.   |
| Worldwide distribution:   | <b>ER-Soft, S.A.</b><br><a href="http://www.er-soft.com">www.er-soft.com</a> , <a href="mailto:info@er-soft.com">info@er-soft.com</a>  |
| Table of Pages:   | <b>Profibus Configuration:</b>   |
| <a href="#">Home</a><br><a href="#">Statistics</a><br><a href="#">Help on configuration</a><br><a href="#">TCP/IP Configuration</a><br><a href="#">Profibus/MPI Configuration</a><br><a href="#">Advanced Profibus Configuration</a><br><a href="#">Change password</a> | <b>Profibus address:</b> <input type="text" value="0"/><br><b>Highest station address:</b> <input type="text" value="31"/><br><br><b>Baudrate:</b> <input type="radio"/> 9.6k <input type="radio"/> 19.2k <input type="radio"/> 31.25k <input type="radio"/> 45.45k <input type="radio"/> 93.75k<br><input checked="" type="radio"/> 187.5k <input type="radio"/> 500k <input type="radio"/> 750k <input type="radio"/> 1.5M <input type="radio"/> 3M <input type="radio"/> 6M<br><input type="radio"/> 12M<br><b>Set Timing for:</b> <input checked="" type="radio"/> MPI <input type="radio"/> Profibus<br><input type="button" value="Configure Profibus"/> <input type="button" value="Reset values"/> |

|   |   |
|---|---|
| <b>xPI-Link</b> by:   | <b>FIELDBUS ELECTRONICS</b><br>...automation interconnect.  |
| Worldwide distribution:   | <b>ER-Soft, S.A.</b><br><a href="http://www.er-soft.com">www.er-soft.com</a> , <a href="mailto:info@er-soft.com">info@er-soft.com</a>   |
| Table of Pages:   | <b>Profibus Configuration:</b>  |
| <a href="#">Home</a><br><a href="#">Statistics</a><br><a href="#">Help on configuration</a><br><a href="#">TCP/IP Configuration</a><br><a href="#">Profibus/MPI Configuration</a><br><a href="#">Advanced Profibus Configuration</a><br><a href="#">Change password</a> | <b>Profibus address:</b> <input type="text" value="0"/><br><b>Highest station address:</b> <input type="text" value="31"/><br><br><b>Baudrate:</b> <input type="radio"/> 9.6k <input type="radio"/> 19.2k <input type="radio"/> 31.25k <input type="radio"/> 45.45k <input type="radio"/> 93.75k<br><input checked="" type="radio"/> 187.5k <input type="radio"/> 500k <input type="radio"/> 750k <input type="radio"/> 1.5M <input type="radio"/> 3M <input type="radio"/> 6M<br><input type="radio"/> 12M<br><b>Initial Tslot:</b> <input type="text" value="415"/><br><b>TQui:</b> <input type="text" value="1"/><br><b>TSet:</b> <input type="text" value="1"/><br><b>Min. Tsdr:</b> <input type="text" value="60"/><br><b>Max. Tsdr:</b> <input type="text" value="400"/><br><b>Token rotation time:</b> <input type="text" value="10000"/><br><b>Gap update time:</b> <input type="text" value="2"/><br><b>Retry Limit:</b> <input type="text" value="2"/><br><b>Gap factor:</b> <input type="text" value="20"/><br><input type="button" value="Configure Profibus"/> <input type="button" value="Reset values"/> |



|   |  |                               |   |                                   |    |                          |   |                          |      |                          |      |                     |       |                 |               |
|---|--|-------------------------------|---|-----------------------------------|----|--------------------------|---|--------------------------|------|--------------------------|------|---------------------|-------|-----------------|---------------|
| <b>xPI-Link</b> by:   | <b>FIELDBUS ELECTRONICS</b><br>...automation interconnect.   |                               |   |                                   |    |                          |   |                          |      |                          |      |                     |       |                 |               |
| Worldwide distribution:   | <b>ER-Soft, S.A.</b><br><a href="http://www.er-soft.com">www.er-soft.com</a> , <a href="mailto:info@er-soft.com">info@er-soft.com</a>  |                               |   |                                   |    |                          |   |                          |      |                          |      |                     |       |                 |               |
| Table of Pages:   | <b>xPI-Link status:</b>  |                               |   |                                   |    |                          |   |                          |      |                          |      |                     |       |                 |               |
| <a href="#">Home</a><br><a href="#">Statistics</a><br><a href="#">Help on configuration</a><br><a href="#">TCP/IP Configuration</a><br><a href="#">Profibus/MPI Configuration</a><br><a href="#">Advanced Profibus Configuration</a><br><a href="#">Change password</a> | <table border="1"> <tr> <td><b>Ethernet packets send:</b></td> <td>8</td> </tr> <tr> <td><b>Ethernet packets received:</b></td> <td>11</td> </tr> <tr> <td><b>Profibus packets:</b></td> <td>0</td> </tr> <tr> <td><b>Profibus status1:</b></td> <td>1010</td> </tr> <tr> <td><b>Profibus status2:</b></td> <td>0462</td> </tr> <tr> <td><b>Up time(ms):</b></td> <td>86449</td> </tr> <tr> <td><b>Up time:</b></td> <td>0 days 0:1:26</td> </tr> </table> | <b>Ethernet packets send:</b> | 8 | <b>Ethernet packets received:</b> | 11 | <b>Profibus packets:</b> | 0 | <b>Profibus status1:</b> | 1010 | <b>Profibus status2:</b> | 0462 | <b>Up time(ms):</b> | 86449 | <b>Up time:</b> | 0 days 0:1:26 |
| <b>Ethernet packets send:</b>   | 8  |                               |   |                                   |    |                          |   |                          |      |                          |      |                     |       |                 |               |
| <b>Ethernet packets received:</b>   | 11   |                               |   |                                   |    |                          |   |                          |      |                          |      |                     |       |                 |               |
| <b>Profibus packets:</b>  | 0  |                               |   |                                   |    |                          |   |                          |      |                          |      |                     |       |                 |               |
| <b>Profibus status1:</b>  | 1010   |                               |   |                                   |    |                          |   |                          |      |                          |      |                     |       |                 |               |
| <b>Profibus status2:</b>  | 0462   |                               |   |                                   |    |                          |   |                          |      |                          |      |                     |       |                 |               |
| <b>Up time(ms):</b>   | 86449  |                               |   |                                   |    |                          |   |                          |      |                          |      |                     |       |                 |               |
| <b>Up time:</b>   | 0 days 0:1:26  |                               |   |                                   |    |                          |   |                          |      |                          |      |                     |       |                 |               |

|   |  |
|---|--|
| <b>xPI-Link</b> by:   | <b>FIELDBUS ELECTRONICS</b><br>...automation interconnect.   |
| Worldwide distribution:   | <b>ER-Soft, S.A.</b><br><a href="http://www.er-soft.com">www.er-soft.com</a> , <a href="mailto:info@er-soft.com">info@er-soft.com</a>                |
| Table of Pages:   | <b>Change password:</b>  |
| <a href="#">Home</a><br><a href="#">Statistics</a><br><a href="#">Help on configuration</a><br><a href="#">TCP/IP Configuration</a><br><a href="#">Profibus/MPI Configuration</a><br><a href="#">Advanced Profibus Configuration</a><br><a href="#">Change password</a> | <p>Enter new password: <input type="text"/></p> <p>Confirm new password: <input type="text"/></p> <p><input type="button" value="Set password"/></p> |

Default:  
Username:  
Password: **ER-Soft**

|   |  |                               |   |                                   |    |                          |   |                          |      |                          |      |                     |       |                 |               |
|---|--|-------------------------------|---|-----------------------------------|----|--------------------------|---|--------------------------|------|--------------------------|------|---------------------|-------|-----------------|---------------|
| <b>xPI-Link</b> by:   | <b>FIELDBUS ELECTRONICS</b><br>...automation interconnect.   |                               |   |                                   |    |                          |   |                          |      |                          |      |                     |       |                 |               |
| Worldwide distribution:   | <b>ER-Soft, S.A.</b><br><a href="http://www.er-soft.com">www.er-soft.com</a> , <a href="mailto:info@er-soft.com">info@er-soft.com</a>  |                               |   |                                   |    |                          |   |                          |      |                          |      |                     |       |                 |               |
| Table of Pages:   | <b>xPI-Link status:</b>  |                               |   |                                   |    |                          |   |                          |      |                          |      |                     |       |                 |               |
| <a href="#">Home</a><br><a href="#">Statistics</a><br><a href="#">Help on configuration</a><br><a href="#">TCP/IP Configuration</a><br><a href="#">Profibus/MPI Configuration</a><br><a href="#">Advanced Profibus Configuration</a><br><a href="#">Change password</a> | <table border="1"> <tr> <td><b>Ethernet packets send:</b></td> <td>8</td> </tr> <tr> <td><b>Ethernet packets received:</b></td> <td>11</td> </tr> <tr> <td><b>Profibus packets:</b></td> <td>0</td> </tr> <tr> <td><b>Profibus status1:</b></td> <td>1010</td> </tr> <tr> <td><b>Profibus status2:</b></td> <td>0462</td> </tr> <tr> <td><b>Up time(ms):</b></td> <td>86449</td> </tr> <tr> <td><b>Up time:</b></td> <td>0 days 0:1:26</td> </tr> </table> | <b>Ethernet packets send:</b> | 8 | <b>Ethernet packets received:</b> | 11 | <b>Profibus packets:</b> | 0 | <b>Profibus status1:</b> | 1010 | <b>Profibus status2:</b> | 0462 | <b>Up time(ms):</b> | 86449 | <b>Up time:</b> | 0 days 0:1:26 |
| <b>Ethernet packets send:</b>   | 8  |                               |   |                                   |    |                          |   |                          |      |                          |      |                     |       |                 |               |
| <b>Ethernet packets received:</b>   | 11   |                               |   |                                   |    |                          |   |                          |      |                          |      |                     |       |                 |               |
| <b>Profibus packets:</b>  | 0  |                               |   |                                   |    |                          |   |                          |      |                          |      |                     |       |                 |               |
| <b>Profibus status1:</b>  | 1010   |                               |   |                                   |    |                          |   |                          |      |                          |      |                     |       |                 |               |
| <b>Profibus status2:</b>  | 0462   |                               |   |                                   |    |                          |   |                          |      |                          |      |                     |       |                 |               |
| <b>Up time(ms):</b>   | 86449  |                               |   |                                   |    |                          |   |                          |      |                          |      |                     |       |                 |               |
| <b>Up time:</b>   | 0 days 0:1:26  |                               |   |                                   |    |                          |   |                          |      |                          |      |                     |       |                 |               |

|   |   |
|---|---|
| <b>xPI-Link</b> by:   | <b>FIELD BUS ELECTRONICS</b><br>...automation interconnect.   |
| Worldwide distribution:   | <b>ER-Soft, S.A.</b><br><a href="http://www.er-soft.com">www.er-soft.com</a> , <a href="mailto:info@er-soft.com">info@er-soft.com</a>   |
| Table of Pages:   | <b>Help on Configuration:</b>   |
| <a href="#">Home</a><br><a href="#">Statistics</a><br><a href="#">Help on configuration</a><br><a href="#">TCP/IP Configuration</a><br><a href="#">Profibus/MPI Configuration</a><br><a href="#">Advanced Profibus Configuration</a><br><a href="#">Change password</a> | <p>All configuration pages show the current value as presets. Change them as you need and then press "Configure" button to send the modified values to the device. The page will reload and should now show the modified values. To make the device work with the new values, switch power off and then repower the device.</p> <p><b>Note that values will NOT take effect until you repower the device!</b></p> <p>What is the difference between Profibus/MPI configuration and Advanced Profibus/MPI configuration?</p> <p>In Profibus/MPI configuration, you choose the devices Profibus address, the baudrate and the highest station address used in your Profibus network. You can also choose MPI or Profibus. The device will then set default values for several Profibus timing parameters, based on your choice of Profibus or MPI. If you want to set these parameters manually, use Advanced Profibus/MPI configuration.</p> <p>If you want to use most default parameters, but change one or two proceed as follows:</p> <ul style="list-style-type: none"> <li>• Goto Profibus/MPI configuration to choose baudrate, HSA and MPI/Profibus.</li> <li>• Press configure so that the device sets default timing parameters.</li> <li>• Now goto Advanced Profibus/MPI configuration and modify the desired parameter(s).</li> <li>• Press configure so that the device accepts your modified timing parameter(s).</li> <li>• Now repower the device.</li> </ul> |

Manufactured in EU by: Fieldbus Electronics.

Distributed Worldwide by:  
ER-SOFT, S.A.  
Av. Constitucion, 4  
E-28231 Las Rozas  
Madrid Spain

Tel: +34 916-408-408  
Fax: +34 916-408-409

web site: [www.er-soft.com](http://www.er-soft.com)  
e-mail: [info@er-soft.com](mailto:info@er-soft.com)