

ProfiHub B5

5 Channel PROFIBUS DP Spur Repeater

ProfiHub B5 is an advanced, flexible and robust network component for PROFIBUS DP installations, to implement long multi-device spur lines and backbone structures with star/tree segments in IP 20 applications.



PROFIBUS DP is a high speed communication bus that has to comply with strict rules concerning spur lines, because of possible reflections that could lead to communication disturbances. If spur lines or star segments are required, costly investments in repeaters have to be done.

The ProfiHub B5 is a perfect economic solution to implement reliable spur lines in high speed DP networks. It has the functionality of 5 galvanic isolated transparent repeaters. This allows network structures with extended spur lines that individually can handle a maximum of 31 devices and a length equal to the main bus.



Dynamic Spur Lines

Allows long spur lines to instruments and the possibility to remove/insert them during operation. Short circuit protection on each spur line is automatically provided.

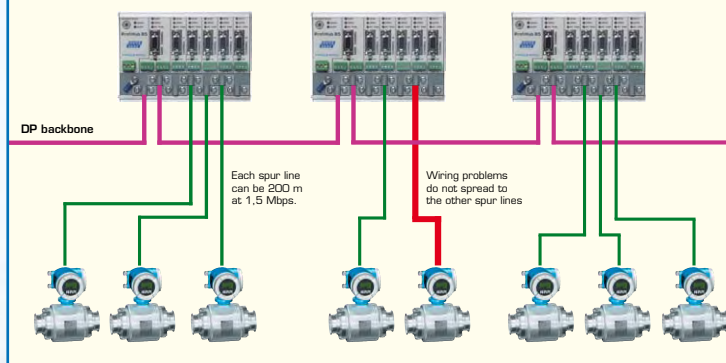

Product features

- 5 Isolated channels (repeater segments).
- Transparent for all PROFIBUS DP protocols.
- DP - RS 485 specifications for each channel.
- 31 devices per channel.
- 9,6 Kbps to 12 Mbps (automatic detection).
- 1.200 m spur line length (depends on transmission speed).
- No limit in serial placement or cascading of ProfiHubs.
- No Address required.
- Integrated termination facilities (switches).
- Configurable grounding system (direct or capacitive).
- Screw terminals and DB9 connectors.
- IP 20 classification (according to DIN 40 050).



Create reliable, flexible and object oriented DP installations with the ProfiHub B5.

PROCENTEC

www.procentec.com/profihub



The ProfiHub B5 is essential to obtain more control during maintenance and upgrading of the network.

Barrier for non certified or EMC sensitive devices

Because of the isolation and intelligence the ProfiHub provides, it can be used as a barrier for electrical sensitive segments. This keeps the backbone and other channels clean.

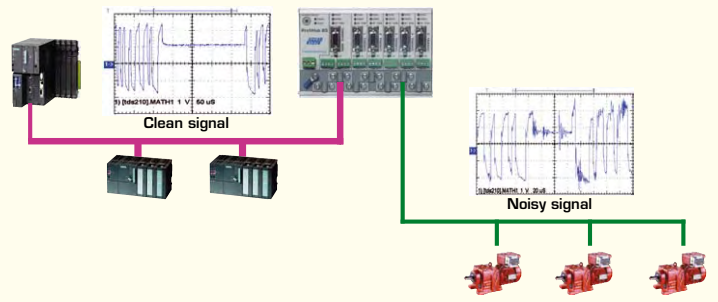

Application Areas

- Dynamic spur lines to actuators, flow meters and pH analyzers.
- Removable drives and motors.
- Pull/Plug motor control centers (drawers).
- EMC sensitive applications.
- Roof mounted devices in Tank Parks.
- Barrier for non galvanic isolated equipment.
- Large star/tree structured networks.

ProfiHub structure

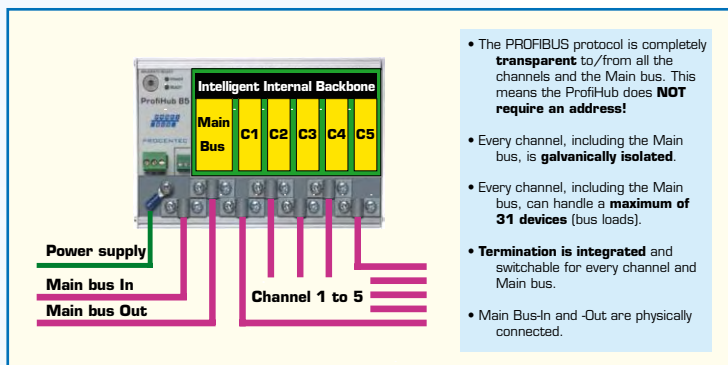

Your Benefits

- Hot slave insertion and removal during operation.
- Short circuit protection on each channel.
- Compact and robust construction.
- Status and error display (per channel).
- Screw terminals and DB9 can be mixed.
- Suitable for all DP cables.
- Conveniently arranged networks.
- Easy extendable installations.
- Cost Savings.



Your Distributor

PROCENTEC

www.procentec.com/profihub

Distribución: ER-SOFT, S.A. Email: er@er-soft.com, Tel: +34 916 408 408