



User Manual

PROFINET Cable Tester

4- and 8-wire industrial PROFINET cable
Straight and 90° metal or plastic PROFINET plugs
Regular Ethernet cable and plugs
Shielding
Wire breaks
Short circuits
Swaps
Miswiring
Split pairs
Can also test telephone and coax cable

Copyright © 2009 PROCENTEC

All rights reserved. No part of this publication may be reproduced, stored in a retrieval system, or transmitted, in any form or by any means, electronic, mechanical, photocopying, recording or otherwise, without the prior written permission of the publisher.

Safety Guidelines

This manual contains notices which you should observe to ensure your own personal safety, as well as to protect the product and connected equipment. These notices are highlighted in the manual by a warning sign and are marked as follows according to the level of danger:



Draws your attention to important information on handling the product, a particular part of the documentation or the correct functioning of the product.

Warning

This device and its components may only be used for the applications described in this manual and only in connection with devices or components that comply with the Ethernet standard. This product can only function correctly and safely if it is transported, stored, set up, installed, operated and maintained as recommended.

Do **NOT** attach to AC power. The cable tester may be damaged and can cause a safety hazard for the user.

Disclaimer of Liability

We have checked the contents of this manual as much as possible. Since deviations cannot be precluded entirely, we cannot guarantee full agreement. However, the content in this manual is reviewed regularly and any necessary corrections included in subsequent editions. Suggestions for improvement are welcomed.

PROCENTEC
Turfschipper 41
2292 JC WATERINGEN
The Netherlands

Tel.: +31-(0)174-671800
Fax: +31-(0)174-671801
Email: info@procentec.com
Web: www.procentec.com



User Manual

PROFINET Cable Tester

4- and 8-wire industrial PROFINET cable
Straight and 90° metal or plastic PROFINET plugs
Regular Ethernet cable and plugs
Shielding
Wire breaks
Short circuits
Swaps
Miswiring
Split pairs
Can also test telephone and coax cable

Copyright © 2009 PROCENTEC

All rights reserved. No part of this publication may be reproduced, stored in a retrieval system, or transmitted, in any form or by any means, electronic, mechanical, photocopying, recording or otherwise, without the prior written permission of the publisher.

Safety Guidelines

This manual contains notices which you should observe to ensure your own personal safety, as well as to protect the product and connected equipment. These notices are highlighted in the manual by a warning sign and are marked as follows according to the level of danger:



Draws your attention to important information on handling the product, a particular part of the documentation or the correct functioning of the product.

Warning

This device and its components may only be used for the applications described in this manual and only in connection with devices or components that comply with the Ethernet standard. This product can only function correctly and safely if it is transported, stored, set up, installed, operated and maintained as recommended.

Do **NOT** attach to AC power. The cable tester may be damaged and can cause a safety hazard for the user.

Disclaimer of Liability

We have checked the contents of this manual as much as possible. Since deviations cannot be precluded entirely, we cannot guarantee full agreement. However, the content in this manual is reviewed regularly and any necessary corrections included in subsequent editions. Suggestions for improvement are welcomed.

PROCENTEC
Turfschipper 41
2292 JC WATERINGEN
The Netherlands

Tel.: +31-(0)174-671800
Fax: +31-(0)174-671801
Email: info@procentec.com
Web: www.procentec.com

Important Information

Purpose of the Manual

This user manual provides information how to work with the PROFINET Cable Tester.

Recycling and Disposal

The parts of the PROFINET Cable Tester can be recycled. For further information about environment-friendly recycling and the procedure for disposing of your old equipment, please contact:

*PROCEN^{TEC}
Turfschipper 41
2292 JC WATERINGEN
The Netherlands*

*Tel.: +31-(0)174-671800
Fax: +31-(0)174-671801
Email: info@procentec.com*

Document Updates

You can obtain constantly updated information on PROCEN^{TEC} products on the Internet at www.procentec.com

You can also contact PROCEN^{TEC} Customer Support:

- By phone at +31-(0)174-671800
- By fax at +31-(0)174-671801
- By email at support@procentec.com

Contents

1	Product Description	7
1.1	Features	7
1.2	Application areas.....	7
2	Operating modes	8
2.1	PROFINET/Ethernet test mode (DATA/SEL Button)	9
2.2	Tone generator (TONE button)	9
2.3	Telephone test mode (VOICE button).....	10
2.4	Coax test mode (VIDEO button)	10
2.5	Split pair test.....	10
2.6	Voltage detection.....	10
2.7	Battery replacement	10
3	Testing PROFINET / Ethernet cable	11
3.1	Interpreting PROFINET test results	13
3.1.1	Correct wiring (with Shield).....	14
3.1.2	Correct wiring (without Shield)	14
3.1.3	Wire break	14
3.1.4	Short circuit.....	15
3.1.5	Miswire.....	15
4	Testing other cable	16
4.1	Testing Video/Coax Cable	16
4.2	Testing Telephone cable	16
4.3	Placing a tone on a cable.....	16
5	Training	17
6	Technical Data	18
7	Hot keys	19
9	Sales offices and Distributors	20
10	Order Codes	23
12	Glossary	24
13	Certificates	25
14	Revision History	27
15	Next version	28
16	Notes	29

1 Product Description

PN1, the first handheld PROFINET cable tester is an essential tool to verify the condition of the PROFINET cable after assembly and installation.

It is a robust tester which has been especially designed for PROFINET and suitable for industrial environments. With just 1 key-press the test result is directly displayed and continuously updated.

If a cable did not pass the test, it will clearly indicate what the problem is and which wires/pins are affected. This product does not require special skills. It is easy to use and gives the technician quick and understandable feedback about the quality of the wiring. It can also be utilized on all other Ethernet networks with 4-wire and 8-wire shielded cables.

This outstanding tool that fits in your pocket will boost the efficiency of installers and maintenance technicians.



1.1 Features

- ✓ Suitable for 4- and 8-wire PROFINET and regular Ethernet cables (CAT6, CAT-5E, CAT-5, CAT-4 and CAT-3).
- ✓ Suitable for straight and 90° metal or plastic PROFINET plugs.
- ✓ Tests cable shielding!
- ✓ Detects short circuits, wire breaks, swaps, miswiring and split pairs.
- ✓ Large LCD clearly indicates the test results.
- ✓ 150 hours on one 9 V battery.
- ✓ Operating temperature: 0 to 50 °C.
- ✓ Just 1-key-press to start continuous testing.
- ✓ It can also test telephone and coax cable.

1.2 Application areas

- ✓ Cable testing during installation phase.
- ✓ Commissioning.
- ✓ Education.

2 Operating modes

The PROFINET Cable Tester runs in 4-modes. The mode is selected with 4 buttons.

☞ The cable tester is switched ON by pressing any of these buttons and it immediately starts testing in the mode which is pressed. An LCD icon for the currently selected mode will be blinking.

☞ Press any button except the selected mode button to switch the cable tester OFF.

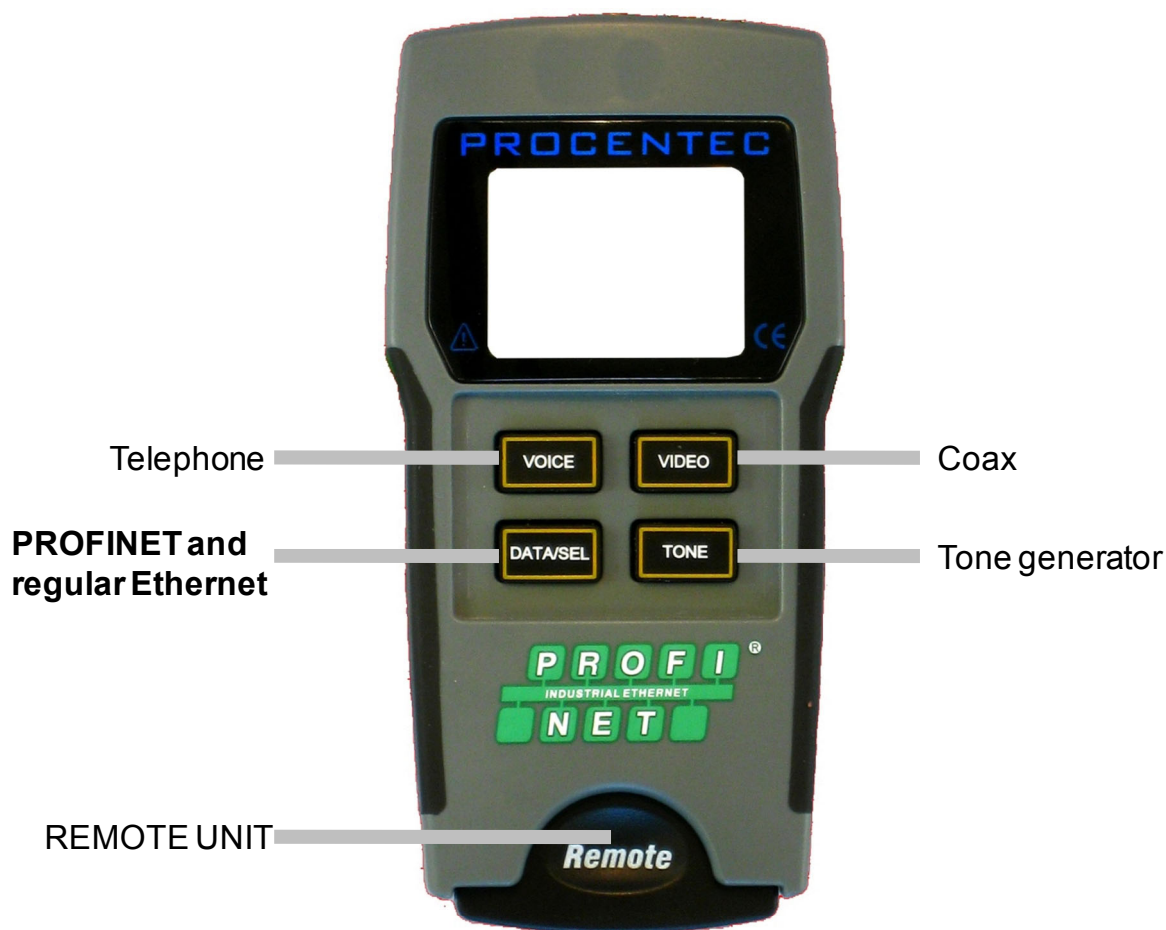

Fig. 1 - Location of the buttons and Remote Unit

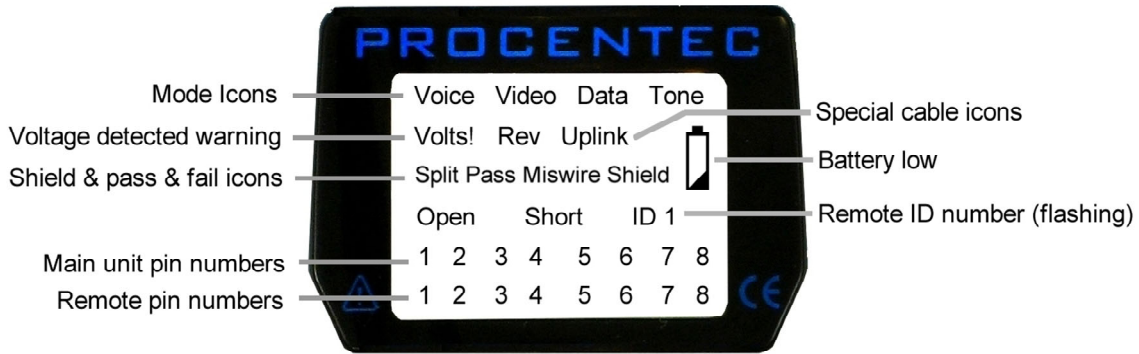

Fig. 2 - LCD layout

2.1 PROFINET/Ethernet test mode (DATA/SEL Button)

In this mode the cable tester uses the RJ 45 Jack on the main unit and the “Remote Unit” to test a cable.

The cable tester can switch between;

- **4 wires / 2-pairs (DATA2 mode)**
PROFINET and other Industrial Ethernet networks with shielded cable.
- **8 wires / 4-pairs (DATA1 mode)**
Regular Ethernet or 1Gbps Industrial Ethernet cable.

☞ Press DATA/SEL for 2 seconds to switch between DATA1 and DATA2 mode.

The tester declares pins 1-2, 3-6, (4-5 and 7-8) as pairs and displays the “Pass” icon when all pins are correctly wired in a one-to-one order. If the 1-2 and 3-6 pairs are crossed, the “Pass” icon will be displayed along with a blinking “Uplink” icon. Uplink cables are also known as cross cables. For shielded cable (PROFINET), the remote ID will flash alternately with “S” to indicate presence of shielding.

2.2 Tone generator (TONE button)

The tone mode generates audio tones for use with tone tracers on selected pins.

The signal generated on a pair has the positive signal on one pin and the complement of the signal on the other pin of the pair, yielding a nominal 10 volts peak-to-peak across the pair.

The pin number of the pin or the letters “P” (for pin) and “S”(for shield) being driven with tone and the currently selected tone pattern is displayed on the screen along with the “Tone” icon and the icon for the connector assumed to be used.

☞ The TONE button steps to the next connector pin(s) drive option when pressed less than 2 seconds.

☞ When the TONE button is pressed and held down for longer than 2 seconds, another tone pattern is selected until the button is released. The tone pattern options are Hi, Lo, HiLo1 and HiLo2. The HiLo options are dual or warble tones of differing pattern duration.

☞ Pressing any button other than TONE, switches OFF the cable tester. The tone will switch OFF automatically after 2,4 hours.

2.3 Telephone test mode (VOICE button)

For this mode the cable tester uses the 6-position jack on the main unit and the remote unit to test a cable. This mode uses the 3-pair USOC standard to define the pairs. Connector pins 1-6, 2-5 and 3-4 are the pairs defined by this standard. The tester will display the “Pass” icon when all 6 pins are correctly wired in a one-to-one order.

If all 6 pins are correctly wired in the reverse order, the “Pass” icon along with a blinking “Rev” icon will be displayed. Standard telephone cables used between a phone set and a wall jack are usually reverse-pinned.

2.4 Coax test mode (VIDEO button)

The cable tester can test wire breaks and short circuits.

2.5 Split pair test

The cable tester has the ability to switch OFF the split pair test. Pressing the button for the current cable test mode for more than 3 seconds, switches OFF the split pair testing. The “Split” icon and its current state (ON or OFF) appear on the screen momentarily to indicate this. The split pair testing will resume the next time the tester is switched ON, or can be toggled by another 3 second press of the current test mode button.

2.6 Voltage detection

The cable tester monitors for voltage being present on the jacks during each test cycle. If voltage is found, the “Volts!” icon is displayed and testing stops until the voltage is removed.

2.7 Battery replacement

When the battery low icon is ON, the battery should be replaced as soon as possible. The cable test results will become unreliable when the battery reaches 4, 5 V. To replace the battery:

- Remove the screw from the battery door on the back of the unit.
- Pull the battery out of the cavity and remove the battery link.
- Connect a new Alkaline 9 V battery to the battery link. Insert the battery back in the compartment with the battery link placed towards the front-end.
- Close the battery door and do **NOT** over tighten the screw.

3 Testing PROFINET / Ethernet cable



BEFORE TESTING STARTS, INSPECT THE PLUGS OF THE CABLE.
 Improperly crimped or damaged plugs can harm the jacks of the cable tester. Do NOT use 6-pin (phone) plugs with the 8-pin RJ 45 jack.

- Take out the Remote Unit of the main unit (squeeze remote at finger grip openings in main unit to remove it).



Fig. 3 - Taking out the Remote Unit

The Remote Unit has to be placed on the other side of the cable. If the cable is short or both ends are very close to each other, the Remote Unit can be left in the main unit.

- ❑ Plug one end of the cable into main unit and the other end of cable into the remote unit.



Fig. 4 - Cable attached to the Main and Remote Unit

- ❑ If PROFINET cable is tested, switch the split pair test OFF!!!

☞ Press the DATA/SEL button for 3 seconds to switch split pair OFF (every time the button is pressed for 3 seconds, split pair operation is toggled). By default the cable tester is set to split pair is ON!

- ❑ To start testing press the DATA/SEL button.

☞ Press DATA/SEL for 2 seconds to switch between DATA1: 8 wires (4 pairs) testing and DATA2: 4 wires (2 pairs) testing. By default the cable tester is set to DATA2!

Results are invalid if a cable is attached during a test in progress!

☞ To switch the cable tester OFF, press the VIDEO button.

3.1 Interpreting PROFINET test results

Upon completion of a cable test, the wire map display, ID and any faults are displayed.

- The top line pin numbers on the display represent the connector pins on the main unit.
- The second line pin numbers represent the connector pin numbers of the remote, normally being the same as the top line for a one-to-one wired cable.

The Pass icon will be ON if the cable has all pins properly connected. The Fail, Short, Open or Split icon will be on if there is a wiring error. The wire map will display the end-to-end connections measured whenever possible.

The Pass icon will also be on with a blinking Uplink icon if a network cable has the 1-2 and the 3-6 pairs transposed to indicate a properly wired uplink/cross cable.



It is very important to check the Shield icon if PROFINET or other Industrial Ethernet cable is tested. IT SHOULD BE ON.

If there are multiple errors to display, there will be a combination of the above error displays. The ID icon will have a number directly to the right of it, indicating the remote ID number detected from the remote. A new test is in progress whenever the “Voice” or “Data” icons are ON.

If a split pair is detected, the detected pins and the “Split” icon will be blinking.



3.1.1 Correct wiring (with Shield)

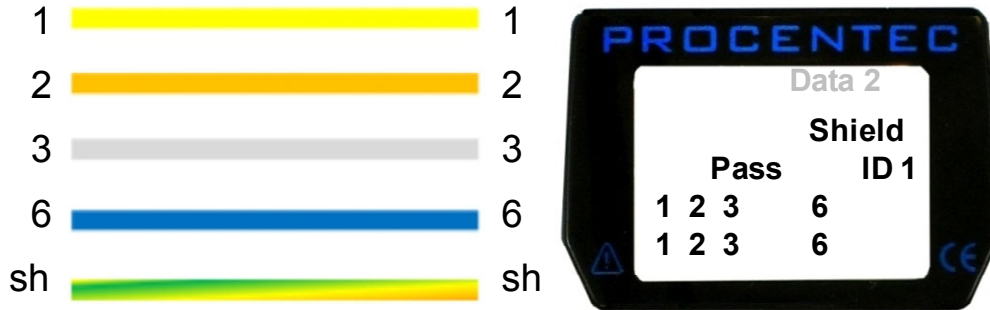

3.1.2 Correct wiring (without Shield)



When the shield has a break or is **NOT** connected, the Shield icon is **NOT** lit. This cable seems to pass, but for PROFINET and other Industrial Ethernet systems, this cable should NOT be approved!

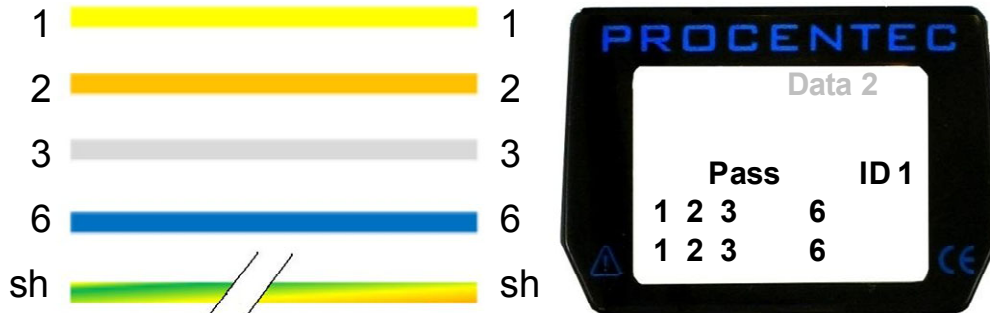

3.1.3 Wire break

If a wire break is detected, the affected pins will be blank and the “Open” icon will be ON (blinking).

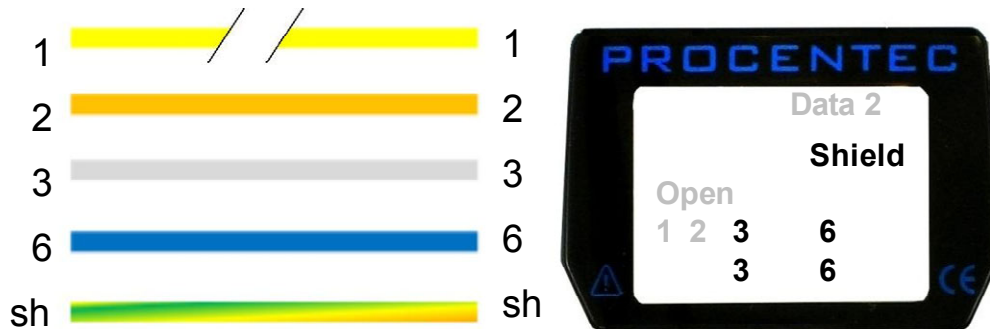

3.1.4 Short circuit

If a short circuit is detected, the second line will have a '-' in those positions along and the "Short" icon will be ON (blinking).

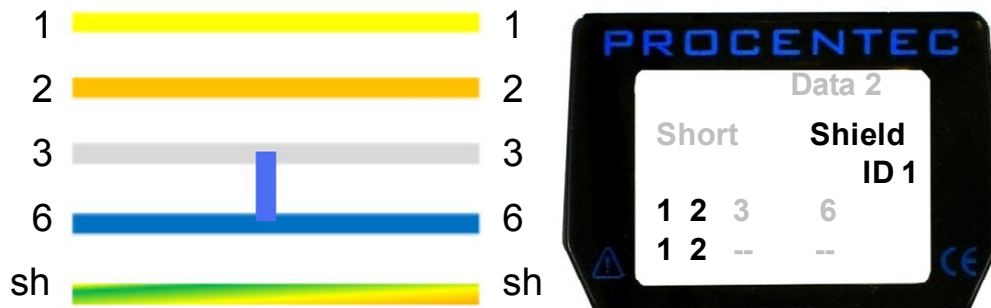

3.1.5 Miswire

If a miswire is detected, the pin numbers will indicate the involved pin numbers and the "Miswire" icon will be ON (blinking).



4 Testing other cable

4.1 Testing Video/Coax Cable

- Attach one end of coax cable to be tested to F-connector on main unit.
- Remove remote unit from main unit by squeezing the remote lightly between the thumb and forefinger through the openings provided in the main unit and pull it out of the main unit and attach it to the other end of the cable to be tested.
- Press the VIDEO button to switch ON the unit and begin testing. The results are updated once a second.

 To switch the cable tester OFF, press the VOICE or DATA button.

4.2 Testing Telephone cable

This is the same procedure as Ethernet cable.

The Rev icon will flash if all connected pins are in reverse order and the Pass icon will also be ON if all 6 connections are present. Telephone modular plug cables used between the wall jack and a phone set are usually reverse pinned.

4.3 Placing a tone on a cable

- Connect the cable to be traced to a main unit jack. For the best signal, do **NOT** connect a remote to the other end. Due to the shielding effect of twisted pairs, the strongest signal is obtained by having one wire of a pair carry tone. Selecting a single pin instead of a pair will do this. For video coax cable, the Tone is best applied to the shield and the shield should **NOT** be additionally grounded.
- Switch ON the cable tester by pressing the button associated with the connector to be used followed by pressing the TONE button. Short presses of the TONE button will select a different pin. Holding down the TONE button for more than 2 seconds will select a different tone pattern.

 To switch the cable tester OFF, press any button except TONE.

The tone will switch OFF automatically after 2,4 hours.

5 Training

This chapter contains an exercise to enhance the practical knowledge of the PROFINET Cable Tester.

Try to recreate the schematic of a “Fault Box” below. It consists of six 2-channel switches which generate faults in the wiring.

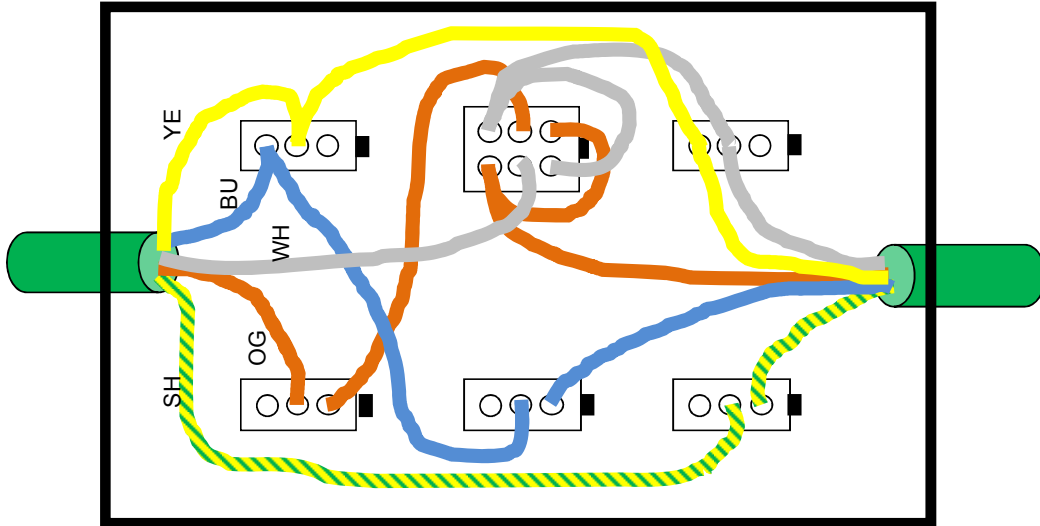

When the box is completed hit each switch and fill-out the fault table below.

	S1	S2	S3	S4	S5	S6
1 or 2 = X						
SH = X						
1 = SH						
2 = 3 → 3 = 2						
2 or 6 = X						
OK						
1 = 6						
SH = 1						
1 = 3						
3 = 1 → 1 = 3						
3 or 6 = X						

6 Technical Data

Dimensions and weight	
Dimensions L x W x H (mm) with DB9 Weight	13,2 × 7,3 × 4,1 cm (5,2 × 2,9 × 1,6 inches) 242 g (8,5 oz.) with battery and Remote Unit
Ambient conditions	
Operating temperature Storage temperature Humidity: Isolation class	0 to 50 °C (32 to 122 °F) -10 to 60 °C (14 to 140 °F) 10 % to 90 %, non-condensing IP 20 (DIN 40 050)
Power supply and operating hours	
Battery Standby Cable testing Tone generator Auto power OFF	9 V Alkaline battery 2,5 years 150 hours 250 hours After 9 minutes the last button was pressed in cable testing modes and after 2,4 hours in tone mode
Ethernet Test	
Cable types Pair resistance to pass test Shield resistance to pass test Cable length for split pair test	Data network cable, CAT6, CAT-5E, CAT-5, CAT-4, CAT-3 Maximum 200 Ohm Maximum 100 Ohm Minimum 2 m cable for testing of split pairs
Coax Test	
Resistance	Maximum 100 Ohm DC resistance, conductor plus shield

7 Hot keys

Action	Button	Holding down Time
Power ON	Any button	Not specified
Power OFF	Any button, except the selected mode button	Not specified
Toggle between - 4-wire (2 pairs) - 8-wire (4 pairs) Ethernet test	DATA/SEL	2 seconds
Toggle split pair testing	DATA/SEL	3 seconds
Select a pin for tone testing	TONE	< 2 seconds
Select a tone pattern	TONE	> 2 seconds

9 Sales offices and Distributors

HEADQUARTERS

PROCENTEC
Turfshipper 41
2292 JC WATERINGEN
Netherlands
Tel.: +31-(0)174-671800
Fax: +31-(0)174-671801
Email: info@procentec.com
Internet: www.procentec.com

ARGENTINA

eFALCOM
Alcorta 2411
B1744- Moreno
Buenos Aires
ARGENTINA
Tel.: +54 237 46 31 151
Fax: +54 237 46 31 150
Email: enrique.modai@efalcom.com
Internet: www.efalcom.com.ar

AUSTRALIA

IS Systems Pty Limited
14 Laverick Ave., Tomago,
NSW, Australia, 2322
Tel.: +61 2 4964 8548
Fax: +61 2 4964 8877
Email: fritz.woller@issystems.com.au
Internet: www.issystems.com.au

Tyco Flow Control Pacific
1 Percival Road, Smithfield,
NSW, Australia, 2164
Tel.: +61 2 9612 2323
Fax: +61 2 9612 2324
Email: nhsmith@typac.com.au
Internet: www.profibuscentre.com.au

AUSTRIA

Dipl.Ing. Christoph Gudenus
Rotenmuehlgasse 40/5
1120 WIEN
Austria
Tel.: +43 1 812 34 20
Fax: +43 1 812 31 55
Email: office@gudenus.at
Internet: www.gudenus.at

BELGIUM

Bintz Technics N.V.
Brixtonlaan 25,
1930 ZAVENTEM
Belgium
Tel.: +32 2 720 49 16
Fax: +32 2 720 37 50
Email: bloemen@bintz.be
Internet: www.bintz.be

BRAZIL

Westcon Instrument. Indl Ltda
Rual Alvaro Rodrigues, 257
São Paulo – SP
Brazil - CEP 04582-000
Tel.: +55 11 5561-7488
Fax: +55 11 5093-2592
Email: paolo@wii.com.br
Internet: www.wii.com.br

Solution Engenharia de Automação
Av. do Contorno, 7962, 10o. andar –
Santo Agostinho, Belo Horizonte, Minas
Gerais – Brasil – CEP 30110-120
Tel.: +55 31 3335-7000
Fax: +55 31 3335-7000
Email: solution@solution-engenharia.com.br
Internet: www.solution-engenharia.com.br

CHILE

RP Ingenieria Limitada
Tucapel 92 oficina 52
Concepción
Chile
Tel.: +56-(0)41-2522592
Fax: +56-(0)41-2522592
Email: rodrigopinto@rpingeneria.cl
Internet: www.rpingeneria.cl

CHINA

CAMETA
Training & Marketing Department
No. 1 Jiao Chang Kou - Room 407
De Sheng Men Wai
BEIJING 100011, China
Tel.: +86-10-82285088 or 62055653
Fax: +86-10-62055653
Email: training@cameta.org.cn
Internet: www.diewen.com

Czech Republic

FOXON e-shop
Polní 367 460 01
Liberec 12
Czech Republic
Tel.: +420 724 578 360
Fax: +420 485 353 192
Email: jaromir.peterka@foxon.cz
Internet: www.foxon.cz

DENMARK

HH Automation A/S
Hovedgaden 451F
DK 2640 HEDEHUSENE
Denmark
Tel.: +45 70 20 52 01
Fax: +45 70 20 52 02
Email: ph@hh-automation.dk
Internet: www.hh-automation.dk

FINLAND

Hantekno Oy
Halsuantie 2,
FIN-00421 HELSINKI
Finland
Tel.: +358 (0)9-530 66 570
Fax: +358 (0)9-530 66 530
Email: hannu.aarrelampi@hantekno.com
Internet: www.hantekno.com

FRANCE

AGILiCOM
Bâtiment B
1, rue de la Briaudière
Z.A. La Châtaigneraie
37510 BALLAN-MIRE
France
Tel.: +33 247 76 10 20
Fax: +33 247 37 95 54
Email: jy.bois@agilicom.fr
Internet: www.agilicom.fr

GERMANY

PROCENTEC GmbH
Haid-und-Neu-Str. 7
D-76131 Karlsruhe
Germany
Tel.: +49-(0)721 626 96 32
Fax: +49-(0)721 626 96 35
Email: tkarnau@procentec.com
Internet: www.de.procentec.com

Brandt-Data GmbH
Friedrich-Hayn-Str. 4
D-24582 Bordesholm
Germany
Tel.: +49 (0)4322-699657
Fax: +49 (0)4322-699658
Email: hbrandt@brandt-data.de
Internet: www.brandt-data.de

profichip GmbH
Einsteinstrasse 6
D-91074 Herzogenaurach
Germany
Tel.: +49-9132-744-200
Fax: +49-9132-744-204
Email: sales@profichip.com
Internet: www.profichip.com

INDIA

U L ELECTRODEVICES P LTD
NIRMAN CLASSIC,
KATRAJ-KONDHWA ROAD,
KATRAJ, PUNE-411046
India
Tel.: +91-202 696 0050
Fax: +91-202 696 2079
Email: dileep.miskin@ulepl.com
Internet: www.ulepl.com

IRELAND

PROFIBUS Ireland
University of Limerick
National Technology Park, Plassey
LIMERICK, Ireland
Tel.: +353-61-202107
Fax: +353-61-202582
Email: info@profibus.ie
Internet: www.profibus.ie

ITALY

C.S.M.T Gestione S.C.A.R.L.
via Branze n. 43/45
25123 BRESCIA
Italy
Tel.: +39 030 3384030
Fax: +39 030 396999
Email: r.miglietti@csmt.it
Internet: www.csmt.it

JAPAN

Japanese PROFIBUS Organization
C/O Siemens K.K.
Takanawa Park Tower
3-20-14 Higashi-Gotanda,
Shinagawa-ku, TOKYO
Japan
Tel.: +81-3-5423-8628
Fax: +81-3-5423-8734
Email: shinichi.motoyoshi@siemens.com

KOREA

Hi-PRO Tech. Co., Ltd.
#812, SEOCHO PLATINUM, 1445-13,
SEOCHO-DONG, SEOCHO-GU, SEOUL,
KOREA
Tel.: +82 (0)2-522-5005
Fax: +82 (0)2-523-5149
Email: chays@hiprotech.co.kr
Internet: www.profibus.co.kr

NETHERLANDS

Ehrbecker Schiefelbusch BV
Postbus 5505
4801 DG BREDA
Netherlands
Tel.: +31-(0)76-5782860
Fax: +31-(0)76-5719261
Email: at@eselektro.nl
Internet: www.eselektro.nl

NORWAY

AD Elektronikk AS
Boks 641
N-1401 SKI
Norway
Tel.: +47 64 97 60 60
Fax: +47 64 97 60 70
Email: kai@ade.no
Internet: www.ade.no

POLAND

INTEX Sp. z o.o.
ul. Wincentego Pola 16
44-100 GLIWICE
Poland
Tel.: +48 32 230 75 16
Fax: +48 32 230 75 17
Email: intex@intex.com.pl
Internet: www.intex.com.pl

Romania

S.C. SVT Electronics S.R.L.
Brăila 7
540331 Tg-Mure
Romania
Tel.: +40 365 809 305
Fax: +40 365 809 305
Email: sajgo.tibor@svt.ro
Internet: www.svt.ro

SINGAPORE

ISEP (S) Pte Ltd
91 Defu Lane 10, #04-02
Swee Hin Building
Singapore 539221
Tel.: +65-63564237
Fax: +65-63467322
Email: chkoo@ise-p.com
Internet: www.ise-p.com

SOUTH AFRICA

IDX ONLINE CC
1 Weaver Street, Fourways
JOHANNESBURG
South Africa
Tel.: +27(11) 465-7916
Fax: +27(11) 465-8890
Email: daveb@idxonline.com
Internet: www.idxonline.com

SPAIN and PORTUGAL

ER-SOFT, SA
Av. Constitucion, 4
E-28230 Las Rozas,
MADRID,
Spain
Tel.: +34 916.408.408
Fax: +34 916.408.409
Email: info@er-soft.com
Internet: www.er-soft.com

SWEDEN

P&L Nordic AB
Box 252,
S-281 23 HÄSSLEHOLM
Sweden
Tel.: +46 451 74 44 00
Fax: +46 451 89 833
Email: hans.maunsbach@pol.se
Internet: www.pol.se/profibus

SWITZERLAND

Hochschule für Technik und Informatik
PROFIBUS Kompetenzzentrum
Jlcoweg 1
CH-3400 BURGDORF
Switzerland
Tel.: +41 (0) 34 426 68 32
Fax: +41 (0) 34 426 68 13
Email: max.felser@bfh.ch
Internet: www.profitrace.ch

Endress+Hauser Process Solutions
Kägenstrasse 2
CH-4153 REINACH / BL1
Switzerland
Tel.: +41 (0) 61 715 73 00
Fax: +41 (0) 61 715 73 01
Email: michael.ulrich@solutions.endress.com
Internet: www.solutions.endress.com

TAIWAN

Full Data Technology
6F., No.200, Gangqian Rd.,
Neihu District, Taipei City
114, Taiwan
Tel.: +886-2-87519941/9097
Fax: +886-2-87519533
Email: sales@fulldata.com.tw
Internet: www.fulldata.com.tw

TURKEY

Emikon Otomasyon
DES Sanayi sitesi 103 sokak B-7 blok No:16
Yukari Dudullu / Umraniye
Istanbul 34776
Turkey
Tel.: +90 216 420 8347
Fax: +90 216 420 8348
Email: tolgaturunz@emikonotomasyon.com
Internet: www.emikonotomasyon.com

UNITED ARAB EMIRATES

Adaptive Measuring and Control
P.O Box-123759 Unit No.424,
Al Diyafah Building, Al- Diyafah Street,
Satwa Dubai,
United Arab Emirates
Tel.: +971-4-3982760
Fax: +971-4-3982761
Email: scsanu@emirates.net.ae

UNITED KINGDOM

Saftronics Limited
Pearson Street, Leeds
LS10 1BQ
United Kingdom
Tel.: +44 (0)113 245 7170
Fax: +44 (0)113 236 4010
Email: ian.robinson@saftronics.co.uk
Internet: www.saftronics.co.uk

iTech
Unit 1
Dukes Road
Troon, Ayrshire KA10 6QR
United Kingdom
Tel.: +44 (0)1292 311 613
Fax: +44 (0)1292 311 578
Email: sales@itech-troon.co.uk
Internet: www.itech-troon.co.uk

Hi-Port Software Limited
The Hub 2 Martin Close
Lee-on-Solent, Hampshire
PO13 8LG,
United Kingdom
Tel.: +44 (0)8452 90 20 30
Fax: +44 (0)2392 552880
Email: sales@hiport.co.uk
Internet: www.hiport.co.uk

Verwer Training & Consultancy
5 Barclay Road
Poynton
Stockport
Cheshire SK12 1YY
United Kingdom
Tel.: +44 (0)1625 871199
Email: andy@verwertraining.com
Internet: www.verwertraining.com

UNITED STATES

Grid Connect Inc.
1630 W. Diehl Road
Naperville, Illinois 60563
USA
Tel.: +1 630 245-1445
Fax: +1 630 245-1717
Email: sales@gridconnect.com
Internet: www.factorycomm.com

URUGUAY

ZyTECH (Kuolong s.r.l.)
Cerro Largo 788 Bis
11100 Montevideo
Uruguay
Tel.: +598 2 901 3311
Fax: +598 2 901 3311
Email: javier@zytech.com.uy
Internet: www.zytech.com.uy

VIETNAM

Bavitech
42 Truong Son Street
Ward 2, Tan Binh District
Ho Chi Minh City
Vietnam
Tel.: +84-8-3547 0976
Fax: +84-8-3547 0977
Email: hai.hoang@bavitech.com
Internet: www.bavitech.com

10 Order Codes

Component	Order code	Remarks
 <p>PROFINET Cable Tester</p>	514-00011A	

12 Glossary

ID	A number that identifies the Remote Unit.
Miswire	Wires are NOT connected to the correct pins at the other end of the cable. The wire map shows the pin numbers line 1 (main) line 2 (remote). A reverse pair is a special case of a miswire in which the pair is wired to the correct pair of pins or to another designated pair of pins, but the two leads are reversed. The Fail icon and the pin numbers, which are miswired, will be blinking.
Short	One of the wires has a low resistance connection from one wire of the pair to the other wire of the pair or to any other wire in the cable or the shield. A short is indicated by the Short icon being on and blinking + the appropriate pin positions on the second line for the pin numbers involved in the shorts plus a blinking S icon if the shield is shorted.
Split pair	A split pair is an error in the twisting of the wires together within the cable. The cables are made up of 4 or 8 wires twisted together in 2 or 4 pairs. These pairs are designated as pairs by the wiring standards and are intended to carry a signal and its return. 1 -2, 3-6, (4-5 and 7-8) are the pairs designated by T568A/B for an RJ45 jack or plug. A cable can be wired with correct continuity but not with correct pairing. This most often happens when the cable is terminated consistently at both ends, but in the wrong order. A dynamic or AC test is required to detect this type of error. If the only error is a split pair error, the cable has correct continuity. If cross talk is not a concern, as in flat satin cable, the cable is good if the only error is the split pair error. The Split icon and the pin numbers on the first and second line of the wire map with split pairs blinking when there is a split pair error.

13 Certificates





Certificate for a PI Competence Center

PI confirms that

**PROCEN^{TEC}
Dennis van Booma
Turfschipper 41
2292 JC Wateringen
THE NETHERLANDS**

*is a fully accredited
PI Competence Center for PROFINET basic.*

*This certificate is granted according to the Quality of Services
Agreement for PI Competence Centers and is valid for 2 years,
until December 31, 2009.*

Karlsruhe, May 05, 2008

.....
(Official in Charge)



Chairmen of PI

Michael Bryant (Chairman)

Jörg Freitag (Deputy Chairman)

14 Revision History

Version 1.0

- First release.

Version 1.1

- Minor adjustments.

Version 1.2

- Updated the Distributors.

15 Next version

- Chapter with theory about PROFINET cabling.
- Chapter with FAQs.
- More items in the glossary.

Other PROCENTEC products



Compact PROFIBUS Repeater

- ✓ Single channel PROFIBUS repeater.
- ✓ Transparent.
- ✓ Increased signal strength.
- ✓ Max. 12 Mbps.
- ✓ Auto baudrate detection.
- ✓ Redundant power supply.
- ✓ Digital glitch filtering.
- ✓ No limit in cascading.
- ✓ Integrated switchable termination.
- ✓ Diagnostic LEDs.
- ✓ DB9 connector for measurements.
- ✓ **IP 20 with DIN-rail mounting.**

www.procentec.com/profihub/b1/en

Other PROCENTEC products



ProfiHub B5

- ✓ 5 Isolated channels.
- ✓ Transparent for PROFIBUS DP.
- ✓ DP - RS 485 specifications.
- ✓ 31 devices per channel.
- ✓ 9,6 Kbps to 12 Mbps.
- ✓ 1200 m spur line length.
- ✓ No Address required.
- ✓ Integrated termination.
- ✓ LEDs that indicate the onboard termination.
- ✓ Screw terminals and DB9 connectors.
- ✓ **IP 20 classification.**

ProfiHub A5

- ✓ 5 Isolated channels.
- ✓ Transparent for PROFIBUS DP.
- ✓ DP - RS 485 specifications.
- ✓ 31 devices per channel.
- ✓ 9,6 Kbps to 12 Mbps.
- ✓ 1200 m spur line length.
- ✓ No Address required.
- ✓ Integrated termination.
- ✓ **IP 65 classification.**



www.procentec.com/profihub

PROCENTEC
Turfschipper 41
2292 JC WATERINGEN
The Netherlands

Tel.: +31-(0)174-671800
Fax: +31-(0)174-671801
Email: info@procentec.com
Web: www.procentec.com