

MPI12X

PRODUCT INFORMATION

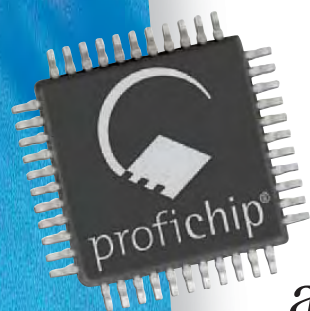

Multi Point Interface Controller



automation in silicon

 **profichip**[®]
automation in silicon

General Description

The profichip **MPI12x** is a combined communication ASIC with 8-Bit Microprocessor interface for MPI and PROFIBUS-DP-Slave.

The **MPI12x** handles the message and address identification, the data security sequences and the protocol processing for Profibus, which is the underlying transport protocol. Token handling, error detection and data pre-processing are carried out automatically, relieving the host processor of all time-critical tasks and time-consuming calculations. Support of data transmission rates up to 12 Mbit/s, the integration of Profibus protocol in the hardware, 4 KByte communication RAM and the configurable microprocessor-interface are features to create high-performance MPI applications.

Moreover the **ProfibusDP Slave** core of the well known VPC3-series (including the DP-V2 service.)

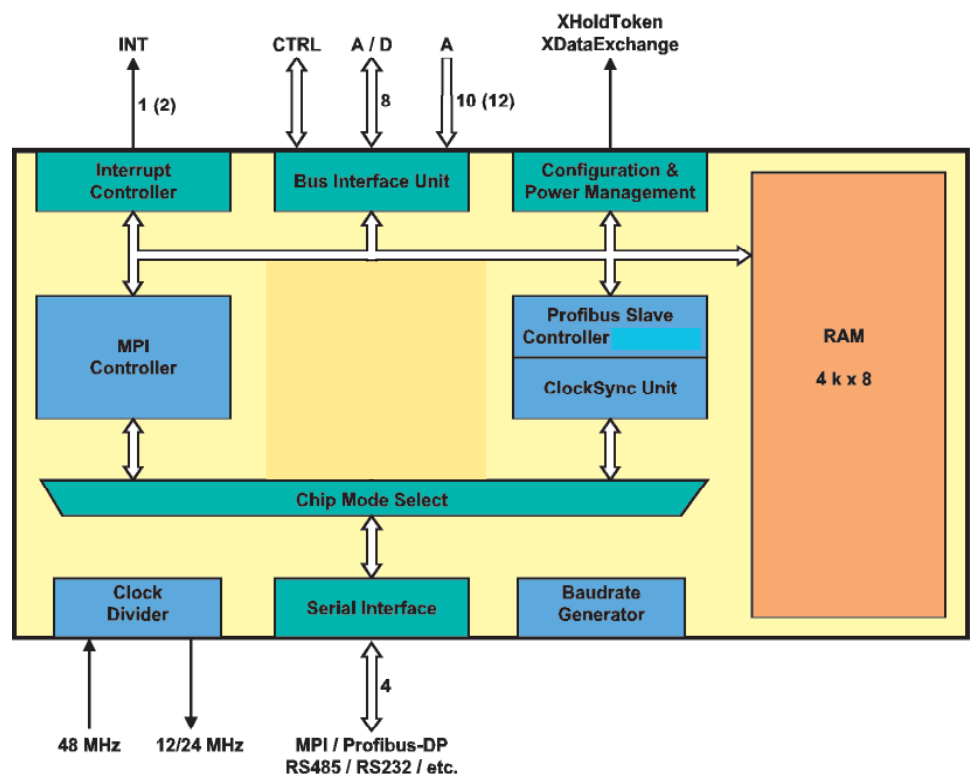

Features:

- MPI communication up to 12MBit/s incl. Token and low-level PB handling
- Additional PROFIBUS-DP slave core (VPC3+C compatible)
- 4kB integrated SRAM
- Configurable 8-Bit μ Controller Interface
- 3.3V single supply voltage / 5V tolerant inputs
- EVA-Kit available
- Software Stack
- Package PQFP44 (RoHS compliant)

The **MPI12x** handles the physical layer 1 and the data link layer 2 of the ISO/OSI-reference-model excluding the Profibus line drivers.

The processor interface supports the following processor families:

Intel:	80C31, 80X86
Siemens:	80C166/165/167
Motorola:	HC11-, HC16-, and HC916

The FLC is connected to the Bus Interface Unit with its 8-bit data bus and a separate 10 bit address bus. The bus mode (synchronous or asynchronous) as well as the microcontroller data format (Intel or Motorola) can be selected by configuration pins.

All registers which configure the chip are located in the „Param“ module. The status register delivers information about the current status of the chip.

Events are stored and asserted by the Interrupt Controller. The events which lead to an interrupt can be locked/unlocked by means of an interrupt mask. The chip has two interrupt lines, one for confirmation and indication, the other for error events. It is also possible to direct all events to only one interrupt line.

The Microsequencer represents the media access state machine. It is responsible for the token handling, generates the request telegrams and filters and processes the indications. If the chip holds the token and there are queued requests, the user data is moved from the RAM to the UART and the correct telegram format is generated automatically. The associated response (if applicable) is stored in the dedicated memory area. Incoming indications are checked for plausibility and valid SAP. Only if both conditions are met, the chip indicates the telegram to the FLC and sends an answer if available.

Besides the user data blocks the internal 4KByte SRAM holds the List-of-Active-Stations (LAS) and the SAP list as well as some additional parameters and the task queues. It is controlled by a Dual Port RAM Controller that arbitrates the RAM access requests from the Bus Interface Unit and the Microsequencer.

The UART converts the internal parallel data to a continuous serial data stream and vice versa. The transmission technique is asynchronous with 1 start-, 8 data-, 1 parity- and 1 stop bit according to the Profibus Standard. The baud rate can be adjusted between 9.6 KBit/s and 12MBit/s.

The Timer Block contains all necessary timers for observing bus activity and controlling the correct protocol timing.

More Information / Orders:

Tel: +49.(0)9132.744.210

Fax: +49.(0)9132.744.204

sales@profichip.com

www.profichip.com

The team of profichip GmbH is developing industrial communication and control ASICs since 1998. Besides the ASICs for PLC-systems' internal communication, the first Profibus Slave Controller **VPC3+** was released in 1999. After this successful launch, profichip extended the range of compatible Profibus Slave ASICs by the Lean Slave **VPCLS** in 2000. Since then, profichip continuously improves available Profibus features in their ASICs. Another evidence for the innovative power of profichip was the realization of the **Speed7 PLC7000** - the first High Performance PLC in silicon. Programmable in Step7^{®*} language, Speed7 marks a substantial progress in the evolution of PLC.

profichip's philosophy exceeds ordinary developing and distribution of ASICs by translating visions into silicon solutions for customer requirements. profichip creates the missing link. The result is automation in silicon.

*= SIEMENS

