

# HIGH SPEED ASICS DESIGNED FOR FUTURE



Professional High-Speed PLC for STEP<sup>®</sup>7 from Siemens





## PLC 7100 - SPEED7 Single Chip for compact PLC's

- Unique single-chip solution for micro to medium size PLCs
- Supported native code: STEP®7\*
- Advanced Speed7 core technology (typ. 20 ns / command)
- Integrated PLC memory up to 128 kB
- ARM926 processor platform with 16 kB + 16 kB caches
- Communication interfaces:
  - PROFIBUS master / MPI (2x)
  - PROFIBUS slave
  - CAN 2.0 A/B (2x)
  - UART, I2C, SPI
  - Ethernet 10/100
  - USB Device
- Counter, SSI, PWM, high-speed IOs
- Low power management
- -40 to +85°C (185°F) ambient temperature

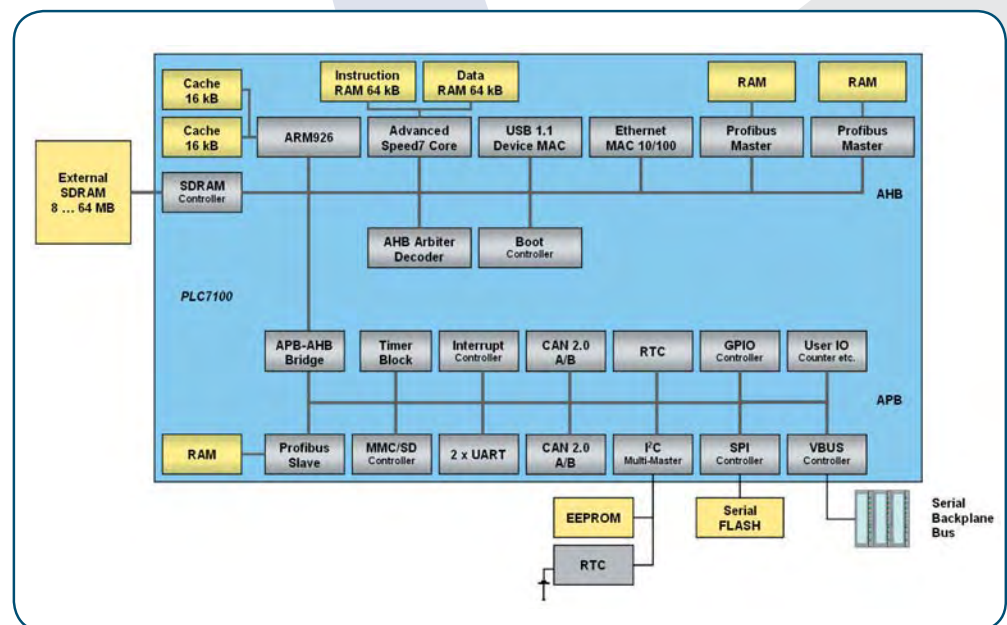

**Relative CPU-Performance (V2.01) compared to SIEMENS S7-318-2DP**  
(pure user code, no SFCS, no PAX, no PEX)

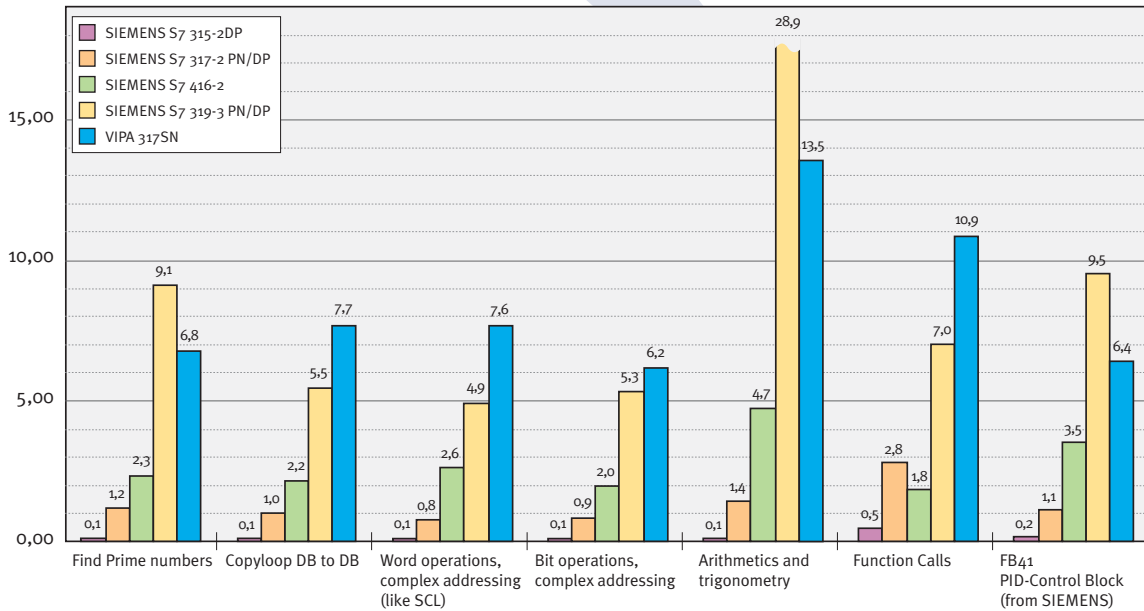

**Relative CPU-Performance (V2.01) compared to SIEMENS S7-318-2DP**  
(pure user code, no SFCS, no PAX, no PEX)

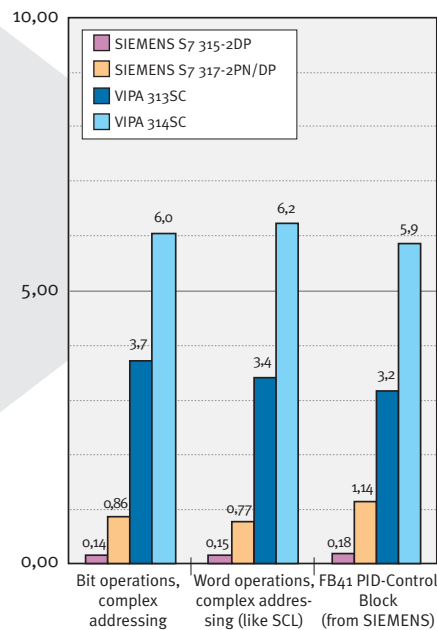

# SPEED7 - HIGHSPEED FOR STEP®7 FROM SIEMENS

CPU	PLC 7001	PLC 7100	PLC 7200
PLC Core	PLC 7000	PLC 7001	PLC 7001
PLC Assembler Code	MC7	MC7+	MC7+
Int. PLC Memory	-	32 kByte	256 kByte
Expandable	up to 8MB	no	yes
System frequency	48/96 MHz	48 MHz	48/96/192 MHz
Int. Cycle Time	20/10 nsec.	20 nsec.	10 nsec.
Co CPU	external	ARM 926EJ	ARM 926EJ
SD-RAM external	4 MByte x 32 Bit	4 MByte x 16 Bit	4 MByte x 32 Bit
Flash-ROM external	1 x 4 MByte	1 x 8 MByte	1 x 8 MByte
<b>System-Interface</b>			
Extension	DPR Interface	-	DPR Interface
On-Board I/Os	32 / 24	32 / 24	32 / 24
Alarm	16	16	■
Counter	4	4	■
SSI In/Out-Master	1/1	1/1	■
PWM	4	4	■
GP I/Os	-	10	20
Test	external	JTAG	JTAG/ETM
V-Bus ser. I/O-Bus	■	■	■
I <sup>2</sup> C 100k/s and 400k/s	-	■	■
SPI, Number of CS	-	2	4
<b>Ethernet Bus Interface</b>			
Ethernet 10/100	-	2 x	2 x
ProFINET RT	-	■	■
EtherCAT	-	■	■
<b>Profibus</b>			
Master, 12 MBit/s	over DPR Interface	1 x	2 x
MPI, 12 MBit/s	2 x <sup>1)</sup>	1 x	1 x
Slave, 12 MBit/s	2 x <sup>1)</sup>	- / 1 x	1 x
<b>Interface</b>			
CAN, 1 MBit/s	-	2 x	2 x
Standard Serial	2 x <sup>1)</sup>	1 x	2 x
High Speed Serial	2 x <sup>1)</sup>	-	1 x
USB 1.1 Device	-	■	■
SD / MMC	-	■	■
<b>PLC System Counter and Timer</b>			
Counter	512	2048	2048
Timer 10 msec.	512	2048	2048
HR-Timer 1µsec.	■	■	■
IEC Timer	max	max	max
RTC no Batt backup	■	■	■
<b>Power Supply</b>			
<sup>1)</sup> a total of 2 interfaces with 4 exclusive options each			
Core Supply	1,8 V	1,5 V	1,5 V
I/O	3,3 V	3,3 V	3,3 V
Power	1,2 Watt	1,2 Watt	1,6 Watt
Temperature	- 25°C - + 85°C	- 25°C - + 85°C	- 25°C - + 85°C
<b>General</b>			
Package	BGA452	BGA256	BGA676
Delivery and Samples	Q 4/06	Q 4/07	Q 4/07
Type of PLC Application	General PLC	µPLC	mini-medium PLC

www.profichip.com

April 2007

