

The logo for ER-SOFT features the letters 'ER' in a large, blue, 3D sans-serif font. To the right of 'ER' is the word 'SOFT' in a smaller, blue, 3D sans-serif font. Above the 'SOFT' text is a stylized red and white graphic element consisting of three horizontal bars of varying lengths, resembling a signal or data indicator. The background is a dark blue grid with glowing fiber optic lines and a bright starburst effect behind the 'ER' text.

fiber optic systems

About eks

eks is your competent and flexible partner in developing and producing electronic systems and communication devices for fiber optic transmission systems.

Our qualified system integrators flexibly create efficient standard solutions as well as product-specific and custom-designed solutions to fit every client's needs. The experience and quality awareness of our company has been rewarded with the DIN EN ISO 9001 certificate.



Innovation, quality, flexibility and cost-consciousness are our corporate principles.

We consider clients as partners and act upon it. At eks we offer excellent products along with intelligent service. Since many years we have been known for, both, quality and innovation as well as extraordinary customer care.

eks broadens its service by distribution contracts with manufacturers of internationally approved high-quality components. The product portfolio of eks includes fiber optic systems for audio, video, phone and multimedia applications. Additionally we offer assembled cables, patch fields, splice boxes and distribution boxes.



Whether you need innovative standard components, assembled cable or compact video converters, we offer fiber optic components for all purposes. For further information about our portfolio please visit our website: www.eks-engel.de or call us today. It is our pleasure to help you.



The high performance of eks products is proven by many satisfied clients every day. Today eks provides fiber optic systems for airports, subways, train stations, cities, tunnels, military bases and highways as well as power plants and ports worldwide. In all of these applications our systems prove to be reliable even under extreme conditions.



Contents

Chapter	Article		Page
Ethernet	EL-100 XS	Mini Media Converter	4 - 5
	EL-100 X	4-Port Ethernet Switch unmanaged	6 - 7
	EL-100 2U	7/8-Port Ethernet Switch unmanaged	8 - 9
	EL-100 2M	7/8-Port Ethernet Switch managed	10 - 11
Fieldbus	DL-485	RS485 Fiber Optic System protocol transparent	12 - 13
	DL-485RS	RS485 Fiber Optic System redundant protocol transparent	14 - 15
	DL-485PB	PROFIBUS Fiber Optic System	
	DL-485PBR	PROFIBUS Fiber Optic System redundant	16 - 17
	DL-485MBP	MODBUS-PLUS Fiber Optic System	
	DL-485MBPR	MODBUS-PLUS Fiber Optic System redundant	18 - 19
	DL-CAN	CAN Fiber Optic System	
	DL-CANR	CAN Fiber Optic System redundant	20 - 21
	DL-422	RS422-Fiber Optic System	22 - 23
	DL-232	RS232 Fiber Optic System	
	DL-232R	RS232 Fiber Optic System redundant	24 - 25
	DL-232MUX	4xRS232-Multiplexer Fiber Optic System	26 - 27
	DL-TTY	TTY-Fiber Optic System	28 - 29
	DL-LWV	Media Converter and Optical Amplifiers	30 - 31
Analog/Digital	IOL-3000	4 x Analog (0-20mA / 0-10V) and 8 x Digital Signals	32 - 33
	IOL-3100	4 x Digital Signals bidirectional	34 - 35
DragonLine	Media Converter	1x10/100 + 1x100FX and 1x10/100/1000 + 1x1000FX, Stand Alone	37
	Media Converter	1x10/100 + 1x100FX and 1x10/100/1000 + 1x1000FX	38
	Switch	5x10/100TX and 8x10/100TX	39
	Switch	4x10/100TX+1x100FX and 4x10/100TX-2x100FX	40
	Switch	5x10/1000TX and 8x10/1000TX	41
	Switch	4x10/100/1000TX+1x1000FX	42
	Switch	16x10/100TX + COMBO: 2x10/100/1000T + 2x100/1000SFP	43
	Switch	6x10/100TX + 2x100FX und 8x10/100Tx + 2x100FX, managed	44 - 45
	Switch	8x10/100TX + 2x1000SX (LX), managed	46 - 47
	Switch	7x10/100TX + COMBO: 3x10/100/1000T + 3x100/1000SFP, managed	48 - 49
	Switch	16x10/100TX + COMBO: 2x10/100/1000T + 2x100/1000SFP, managed	50 - 51
	Switch	6x10/100TX + COMBO: 2x10/100/1000T + 2x100/1000SFP, managed	52 - 53
	PoE Media Conv.	1x10/100TX PoE + 1x100FX	54
	PoE Switch	4x10/100TX PoE + 1x10/100TX	55
	PoE Switch	4x10/100TX PoE + 1x100FX	56
	PoE Switch	8x10/100TX PoE + COMBO: 2x10/100/1000T + 2x1000SFP	57
	PoE Switch	8x10/100TX PoE + COMBO: 2x10/100/1000T + 2x1000SFP, managed	58 - 59
	PoE Switch 19"	24x10/100TX PoE + COMBO: 2x10/100/1000T + 2x1000SFP, managed	60 - 61
	Device Server	1xRS232/422/485 to 2x100TX	62 - 63
	19"-Switch	24x10/100TX or 24x100FX + 2x1000 Uplink, modular, managed	64 - 65
	19"-Switch	24x10/100/1000TX or 24x1000FX, modular, managed	66 - 67
	19"-Switch	24x10/100TX + 4x1000 SFP Shared, managed	68 - 69
19"-Switch	48x10/100TX + COMBI: 2x100/1000T + 2x1000SFP Shared	70	
VDSL2-Extender	Ethernet to VDSL2 Extender	71	
Audio/Video	Audio-, Video-, Telephone-, E1- and E3-Systems	72 - 73	
Accessory	FIMP	Compact Splice Box, up to 12 Fibers	74 - 75
	FIMP-XL	Compact Splice Box, up to 24 Fibers	76 - 77
		Patchfields, Spliceboxes, Cables	78
Service	Development, Project Planning, Customizing	79	

Please note,

this catalog shows only a selection of our portfolio.

Please ask for your application or visit our website www.eks-engel.de.

Subject to modification!

© eks Engel GmbH & Co. KG / Version 11/2009 English

EL-100 XS

Mini-Media Converter unmanaged

System description

The series EL-100 XS contains unmanaged media converters which operate with POF, HCS-, multimode or single-mode fiber optic. Additional features are autonegotiation, MDX/ MDIX, redundant power supply and extended temperature range.

The flat design of the stainless steel housing offers an extremely high degree of flexibility and safety for all kinds of indoor and outdoor applications. e-lightxs can either be mounted onto a DIN EN rail or fastened onto the wall. A clip is already included in the scope of delivery. e-lightxs is suitable wherever there is little space, e.g. in small distribution boxes.

Important performance features of the transfer with POF, HCS, multimode or singlemode fiber optic are the electromagnetic ruggedness, the potential separation of transmitter and receiver, as well as ranges up to 100km between two fiber optic systems. In addition to ST, SC and SMA the connection type E2000 is also available. All systems can communicate via two as well as one fiber with the help of the BIDI-technology with SC port.

In connection with other systems out of the e-light and DragonLine series respectively, individual applications can be realized.

Please inquire your requested type if it is not listed in the adjoining chart.



Application

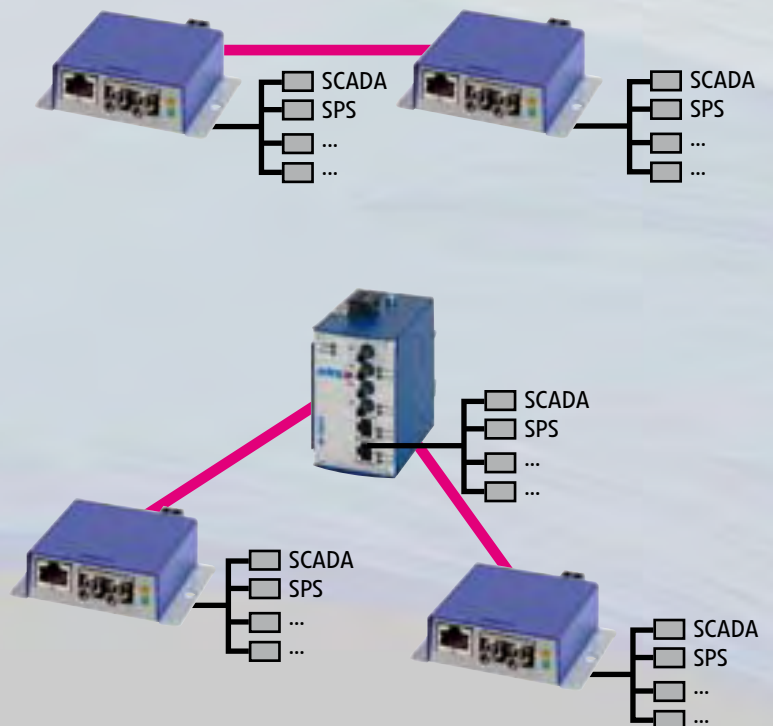

Ordering Information

Type	6-P-ST	6-P-SM	13-MM-ST	13-MM-SC	13-MM-SC /BIDIA(B)	13-SM-ST	13-SM-SC	13-SM-E2	13-SM-SC /BIDIA(B)
Order no. EL100 XS/	0 42000 101EV10-00	0 42000 102EV10-00	0 42000 131EV10-00	0 42000 133EV10-00	0 42000 136EV10-00 (BIDIA) 0 42000 137EV10-00 (BIDIB)	0 42000 151EV10-00	0 42000 153EV10-00	0 42000 155EV10-00	0 42000 156EV10-00(BIDIA) 0 42000 157EV10-00 (BIDIB)
FO connector	ST	SMA	ST	SC	SC	ST	SC	E-2000	SC
Fiber	POF 980/1000 μm	HCS 200/230 μm	Multimode 62,5 (50) /125 μm			Singlemode 9/125 μm			
Optical budget	12 dB		12 dB		15 dB	16 dB			
FO range	40 m (180 dB/km)	200 m (8 dB/km)	5 km (1 dB/km)			30 km, others up to 100km on request (0,3 dB/km)			
Wavelength	650 nm	850 nm	1300 nm		1300 nm 1510 nm	1300 nm			1300 nm 1510 nm
Status - LEDs	TX data per port								
Operating voltage	12-24 VDC								
Operating temperature	-30°C - +75°C								
EMC	EN61000-6-2 (2001) / EN55022 Kl. B (1998) +A1 + A2								
Weight	200 g								
Dimensions H x W x D	H: 25 mm W: 62 mm D: 80 mm								
Housing	Stainless steel, powder coated								

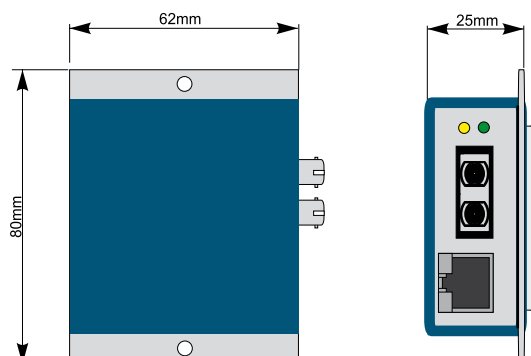

EL-100 X

Unmanaged 4-Port Switch



System description

In Ethernet Networks the network availability is directly related to the production processes. Therefore error-resistant network components are essential to avoid network outages which could lead to production standstills.

The series EL-100 X contains unmanaged 4-Port-switches for 10/100MBit/s with optionally up to four RJ45-Ethernet-Ports and up to two optical ports which operate with POF, HCS-, multimode or singlemode fiber optic. Additional features are autonegotiation, MDX/ MDIX, redundant power supply and extended temperature range.

Important performance features of the transfer with POF, HCS, multimode or singlemode fiber optic are the electromagnetic ruggedness, the potential separation of transmitter and receiver, as well as ranges up to 100km between two fiber optic systems. LEDs and potential-free contacts (optional) of a fault detector relay are able to signal defective states.

In addition to ST, SC and SMA the connection type E2000 is also available. All systems can communicate via two as well as one fiber with the help of the BIDI-technology with SC port.

Please inquire your requested type if it is not listed in the adjoining chart.

Application

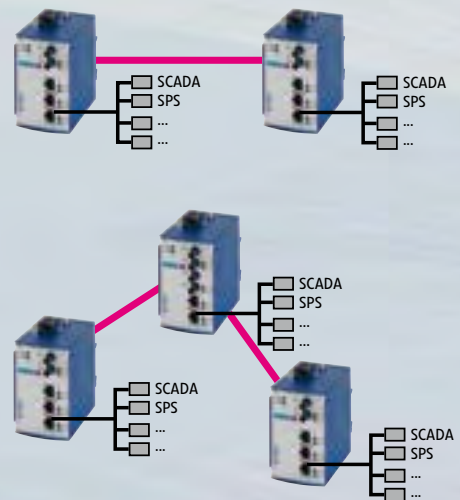

Ordering Information

Type ST EL100 X/	4TX	3TX-1FX- ST-MM	2TX-2FX- ST-MM		3TX-1FX- ST-SM	2TX-2FX- ST-SM			
Order no.	0 670 300	0 670 301	0 670 302		0 670 351	0 670 352			
Type SC EL100 X/	3TX-1FX- SC-MM	2TX-2FX- SC-MM	2TX-2FX- SC-MM- BIDI	3TX-1FX- SC-MM- BIDI	3TX-1FX- SC-SM	2TX-2FX- SC-SM	3TX-1FX- SC-SM- BIDI	2TX-2FX- SC-SM- BIDI	
Order no.	0 670 311	0 670 312	0 670 312 BIDI	0670311 BIDI	0 670 361	0 670 362	0670361 BIDI	0 670 362 BIDI	
Type E2000 EL100 X/	3TX-1FX- E2-MM	2TX-2FX- E2-MM			3TX-1FX- E2-SM	2TX-2FX- E2-SM			
Order no.	0 670 331	0 670 332			0 670 381	0 670 382			

Fiber	Multimode 62,5 (50) /125µm	Singlemode 9/125µm
Optical Budget	12 dB 3 dB system reserve	16 dB 3 dB system reserve
FO range	5 km (1 dB/km)	30 km, others up to 100km on request (0,3 dB/km)
Wavelength	1300 nm (BIDI: 1300 nm / 1550 nm)	
Status - LEDs	System fault (red) / Port LEDs (yellow/green) / Power supply (green)	
Operating voltage	12-30 VDC, other voltages on request	
Power consumption	200 mA	
Potential separation	500 V	
Operating temperature	-25°C - +60°C	
Storage temperature	-40°C - +85°C	
EMC	EN61000-6-2 / EN55022 class B +A1 + A2	
Failure relay	Relay output (30VDC / 1A oder 250AC / 1A)	
Weight	500 g	
Dimensions H x W x D	H: 100mm W: 61mm D: 113mm	
Housing	Stainless steel, powder coated	

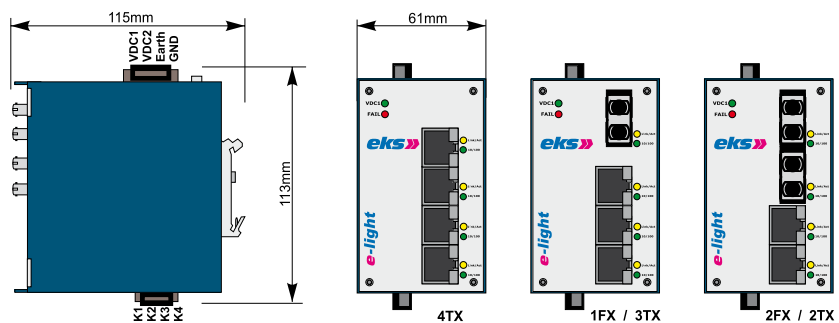

EL-100 2U

Unmanaged 7/8-Port Switch



System description

In Ethernet Networks the network availability is directly related to the production processes. Therefore error-resistant network components are essential to avoid network outages which could lead to production standstills.

The series EL-1002U contains unmanaged 7/8-Port-switches for 10/100MBit/s with optionally up to eight RJ45-Ethernet-Ports and up to three optical ports which operate with POF, HCS-, multimode or singlemode fiber optic. Additional features are autonegotiation, MDX/MDIX, redundant power supply and extended temperature range.

Important performance features of the transfer with POF, HCS, multimode or singlemode fiber optic are the electromagnetic ruggedness, the potential separation of transmitter and receiver, as well as ranges up to 100km between two fiber optic systems. LEDs and potential-free contacts (optional) of a fault detector relay are able to signal defective states.

In addition to ST, SC and SMA the connection type E2000 is also available. All systems can communicate via two as well as one fiber with the help of the BIDI-technology with SC port.

Please inquire your requested type if it is not listed in the adjoining chart.

Application

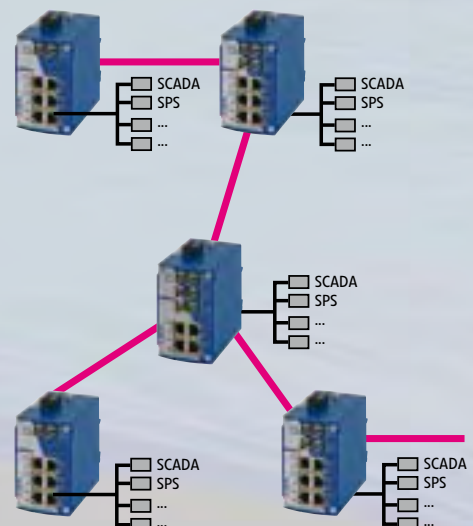

Ordering Information

Type ST EL100 2U/	8TX	6TX-1FX-ST-MM	6TX-2FX-ST-MM	4TX-3FX-ST-MM	6TX-1FX-ST-SM	6TX-2FX-ST-SM	4TX-3FX-ST-MM		
Order no. 0 4000 01	00 00 00	00 00 31	00 31 31	31 31 31	00 00 51	00 51 51	51 51 51		
Type SC EL100 2U/		6TX-1FX-SC-MM	6TX-2FX-SC-MM	4TX-3FX-SC-MM	6TX-1FX-SC-SM	6TX-2FX-SC-SM	4TX-3FX-SC-MM		
Order no. 0 4000 01		00 00 33	00 33 33	33 33 33	00 00 53	00 53 53	53 53 53		
Type E2000 EL100 2U/		6TX-1FX-E2-MM	6TX-2FX-E2-MM	4TX-3FX-E2-MM	6TX-1FX-E2-SM	6TX-2FX-E2-SM	4TX-3FX-E2-MM		
Order no. 0 4000 01		00 00 35	00 35 35	35 35 35	00 00 55	00 55 55	55 55 55		
Fiber	Multimode 62,5 (50) / 125µm			Singlemode 9/125µm					
Optical budget	12 dB 3 dB System reserve			16 dB 3 dB System reserve					
FO range	5 km (1 dB/km)			30 km, others up to 100km on request (0,3 dB/km)					
Wavelength	1300 nm								
Status - LEDs	System fault (red) / Port LEDs (yellow/green) / Power supply (green)								
Operating voltage	12-30 VDC redundant power supply, other voltages on request								
Potential separation	500 V								
Operating temperature	-25°C - +60°C								
Storage temperature	-40°C - +85°C								
EMC	EN61000-6-2 / EN55022 class B +A1 + A2								
Failure relay	Relay output (30VDC / 1A oder 250AC / 1A)								
Weight	500 g								
Dimensions H x W x D	H: 100mm W: 61mm D: 113mm								
Housing	Stainless steel, powder coated								

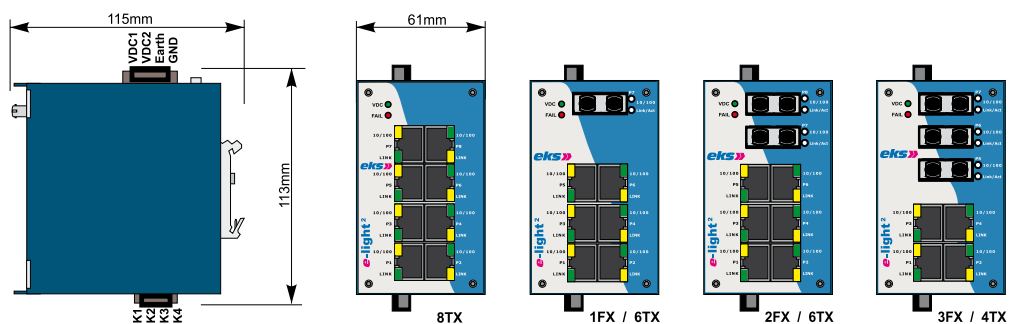

EL-100 2M

Managed 7-/8-Port Switch with up to 4FX-Ports



System description

e-light2M is a 8 port switch that features ring function based on the Pathfinder Ring (P-Ring) with a recovery time of less than 300ms.

They are available with up to 4 flexibly configurable FX-ports and up to 6TX-ports. The Fast Ethernet switches with their industrial design are useable in a wide temperature range of -30°C to +75°C and are suitable for both DIN rail mounting and wall fastening.

The e-light2M management highlights are amongst others: Web Management GUI, Port Mirroring, DHCP Client, IGMP, SNMP, SMTP, port and tagged based VLAN, SNMP in connection with Web Management and RMON, quality of service as well as an alarm relay output for system events

Important performance features of the transfer with multimode or singlemode fiber optic are the electromagnetic ruggedness, the potential separation of transmitter and receiver, as well as ranges up to 100km between two fiber optic systems. LEDs and potential-free contacts of a fault detector relay are able to signal defective states.

Additional features are autonegotiation, MDX/ MDIX and redundant power supply with an input voltage range from 19VDC to 60VDC.

Application

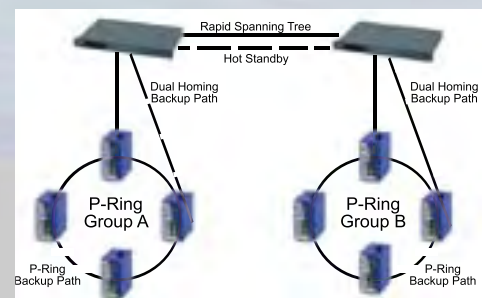
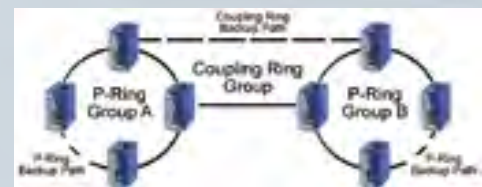
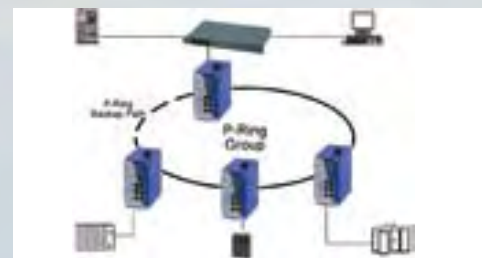

Ordering Information

Type EL100 2M/	6TX-2FX- PO-ST	6TX-2FX- HC-ST	6TX-2FX- MM-ST	6TX-2FX- MM-SC	6TX-2FX- MM-SC- BIDI	6TX-2FX- SM-ST	6TX-2FX- SM-SC	6TX-2FX- SM-SC- BIDI	6TX-2FX- SM-E2
Order no. 04100010	00101EV1 0-00	01111EV1 0-00	03131EV1 0-00	03333EV1 0-00	03637EV1 0-00	05151EV1 0-00	05353EV1 0-00	05657EV1 0-00	05555EV10 -00
Fiber	POF 980/1000µm		HCS / PCF 200/230µm		Multimode 62.5 (50) / 125µm		Singlemode 9/125µm		
Optical budget	12 dB (3 dB System reserve)		12 dB (3 dB System reserve)		12 dB / BIDI 15 dB (3 dB System reserve)		16 dB (3 dB System reserve)		
FO range	40 m		200 m		5 km		30 km, others on request		
Wavelength	650 nm		850 nm		1300 nm				
Status - LEDs	System fault (red) / Port LEDs (yellow / green) / Power supply (green)								
Power supply	12-70 VDC redundant power supply								
Potential separation	500 V								
Operating temperature	-25°C - +60°C								
Storage temperature	-40°C - +85°C								
EMC	EN61000-6-2 / EN55022 class B +A1 + A2								
Weight	500 g								
Dimensions H x W x D	H: 145mm W: 70mm D: 130mm								
Housing	Stainless steel, powder coated								
IEEE	IEEE 802.3 10Base-T / IEEE 802.3u 100Base-TX and 100Base-FX Fast Ethernet / IEEE802.3x Flow Control and Back-pressure / IEEE802.1d STP / IEEE802.1w RSTP / IEEE802.1p class of service / IEEE802.1Q VLAN Tag								
Protocol	CSMA/CD								
Management	SNMP management / Web interface management								
SNMP MIB	RFC 1213 MIBII / RFC 1493 Bridge MIB / RMON RFC 1757 / RFC 2674 VLAN MIB / RFC 1643 Ethernet like MIB / RFC 1215 Trap MIB / Private MIB for switch information, ring, port alarm, TFTP firmware upgrade, reset, port mirror, IP security management, IGMP management MIB								
Technology	Store and forward switching architecture								
SNMP Trap	Up to 3 traps / cold start / port link up / port link down / authentication fault / Private trap for power status / port alarm configuration / fault alarm ring								
Transfer Rate	14,880 pps for 10Base-T Ethernet port / 148,800 pps for 100Base-TX/FX Fast Ethernet port								
MAC Address table	2K MAC address table								
Packet filter	4 types of packet filter rules with different packet combinations								
Ring	2 Ports for the ring guarantee a recovery time of less than 30 ms								
VLAN	Port based VLAN / Q Tag VLAN IEEE802.1								
Class of Service	IEEE802.1p Class of Service with 4 priority queues								
Spanning Tree	IEEE802.1d Spanning Tree and IEEE802.1w Rapid Spanning Tree								
IGMP	IGMP v1 and Query Modus, with up to 256 groups								
SMTP	SMTP for time synchronisation / SMTP Server and four email accounts for system events								
IP Security	IP-address security to refuse access to unauthorized users								
Port Mirror	Only TX packet or TX and RX packets								
Firmware Update	TFTP firmware update, TFTP backup and restore								
Alarm contact	Relay output (30VDC / 1A or 250AC / 1A)								
Bandwidth control	Ingress and egress with combination possibilities								
DHCP Client	DHCP client function to keep the IP address of the DHCP server								

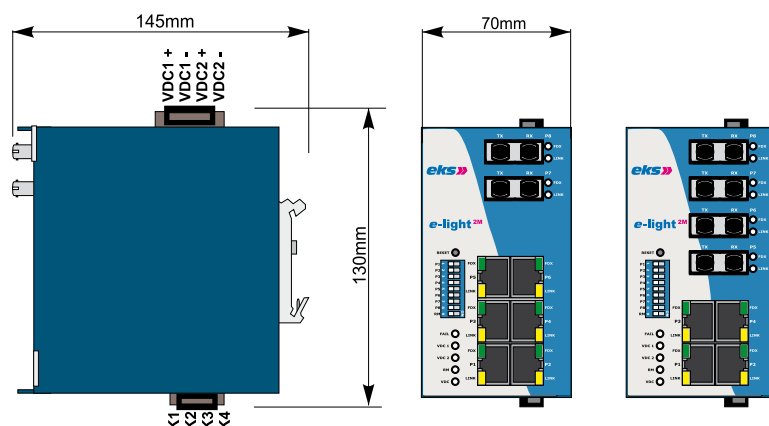

DL-485

RS485-Fiber Optic System



System description

The fiber optic systems DL-485 connect field bus systems with RS485 interfaces. Optical linking allows safe data transfer and is suitable for PROFIBUS, MODBUS, MODNET-1/ SFB, BIT-BUS, SAIA-S-BUS and several manufacturer-specific systems.

With the help of this innovative system optical bus, star, tree and mixed structures are possible.

Important performance features of the transfer with POF, HCS, multimode or singlemode fiber optic are the electromagnetic ruggedness, the potential separation of transmitter and receiver, as well as ranges up to 100km between two fiber optic systems. LEDs and potential-free contacts (optional) of a fault detector relay are able to signal defective states.

In addition to ST, SC, SC-BIDI and SMA, also the optical connection type E2000 is available.

Furthermore RS485- fiber optic systems are available as RS485-Four-Wire and in the following designs:



LCON-1



LCON-2

Application

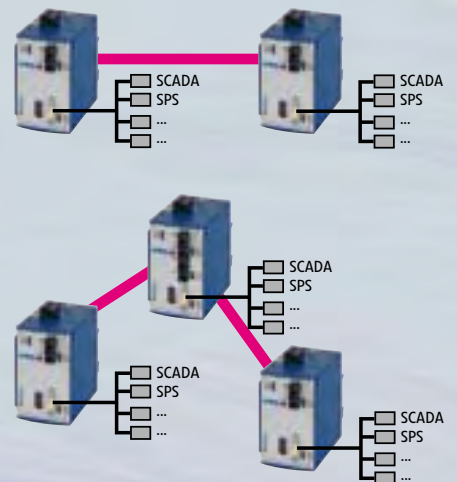

Ordering Information

Type	6-P-ST	6-P-SM	13-MM-ST	13-MM-SC	13-MM-SC /BIDI	13-SM-ST	13-SM-SC	13-SM-E2	13-SM-SC /BIDI
Order no. DL-485	0 1000 6101	0 1000 6102	0 1000 6121	0 1000 6123	0 1000 6123 BIDIA 6123-BIDIB	0 1000 6131	0 1000 6133	0 1000 6135	0 1000 6133 BIDIA 6133-BIDIB
Order no. DL-485/2x	0 1000 6151	0 1000 6152	0 1000 6171	0 1000 6173	0 1000 6173 BIDI	0 1000 6181	0 1000 6183	0 1000 6185	0 1000 6183-BIDI
FO connector	ST	SMA	ST	SC	SC	ST	SC	E-2000	SC
Fiber	POF 980/1000 μm	HCS 200/230 μm	Multimode 62,5 (50) /125 μm			Singlemode 9/125 μm			
Optical budget	12 dB	15 dB	12 dB			17 dB			
FO range	50 m (180dB/km)	120 m (10dB/km)	5 km (1 dB/km)			30 km, others up to 100km on request (0,4 dB/km)			
Wavelength	650 nm		1310 nm		1310 nm 1550 nm	1310 nm			1310 nm 1550 nm
Data rate max.	1.200 Bit/s to 3 Mbit/s								
Transmission type	Half-duplex								
Signal delay	RS485 ↔ LWL : < 3 TBit / Tx ↔ Rx : 11 TBit								
Terminating resistor	Switchable: none or wave impedance (Rw + Rpd + Rpu)								
Cable length electr.	1.200 m (9,6 – 187,5 Kbit/s), 400 m (500 Kbit/s), 200 m (1.5 Mbit/s)								
Connecting plug	9 pole Sub-D female and 6 pole terminal								
Status - LEDs	Power supply (green) / Data (yellow) / Status (red)								
Operating voltage	12-30 VDC, other voltages on request								
Power consumption	200 mA								
Potential separation	500 VDC (24 VDC → RS485)								
Operating temperature	-40°C - +70°C								
Storage temperature	-40°C - +85°C								
EMC	EN61000-6-2 (2001) / EN55022 class B (1998) +A1 + A2								
Weight	500 g								
Dimensions H x W x D	H: 115 mm B: 61 mm T: 113 mm								
Housing	Stainless steel, powder coated								

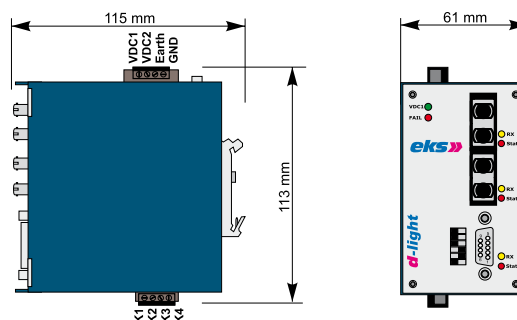

DL-485RS

RS485-Fiber Optic System Redundant



System description

The fiber-optic systems DL-485RS secure the optical data transfer within RS485-field bus networks up to a data speed of 19,2KBit/s. Our special multifunctional fiber optic system also allows the construction of optical ring structures.

The system of this series is especially suitable for applications with strict safety-related requirements as for instance: process industry, tunnel ventilation systems and railway technology.

Important performance features of the transfer with POF, HCS, multimode or singlemode fiber optic are the electromagnetic ruggedness, the potential separation of transmitter and receiver, as well as ranges up to 100km between two fiber optic systems. LEDs and potential-free contacts (optional) of a fault detector relay are able to signal defective states.

In addition to ST and SC the optical connection type E2000 is also available. All systems can communicate via two as well as one fiber with the help of the BIDI-technology with SC port.

Please inquire your requested type if it is not listed in the adjoining chart.

Application

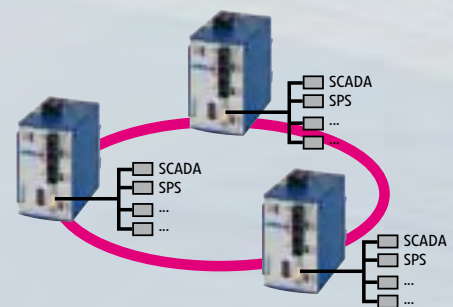

Ordering Information

Type	6-P-ST	6-P-SM	13-MM-ST	13-MM-SC	13-MM-SC /BIDI	13-SM-ST	13-SM-SC	13-SM-E2	13-SM-SC /BIDI
Order no. DL-485RS/2x	0 1000 6851	0 1000 6852	0 1000 6871	0 1000 6873	0 1000 6873-BIDI	0 1000 6881	0 1000 6883	0 1000 6885	0 1000 6883-BIDI
FO connector	ST	SMA	ST	SC	SC	ST	SC	E-2000	SC
Fiber	POF 980/1000 μm		Multimode 62,5 (50) /125 μm			Singlemode 9/125 μm			
Optical budget	12 dB		13 dB			17 dB			
FO range	50 m (180dB/km)		5 km (1 dB/km)			30 km, others up to 100km on request (0,4 dB/km)			
Wavelength	650 nm		1310 nm		1310 nm 1550 nm	1310 nm			1310 nm 1550 nm
Data rate max.	19,2 Kbit/s								
Transmission type	Half-duplex								
Signal delay	RS485 ↔ Fiber Optic : < 3 TBit / Tx ↔ Rx : 11 TBit								
Terminating resistor	Switchable: none or wave impedance (Rw + Rpd + Rpu)								
Cable length electr.	1.200 m								
Connecting plug	9 pole Sub-D female and 6 pole terminal								
Status - LEDs	Power supply (green) / Data (yellow) / Status (red)								
Operating voltage	12-30 VDC, other voltages on request								
Power consumption	200 mA								
Potential separation	500 VDC (24 VDC → RS485)								
Operating temperature	-40°C - +70°C								
Storage temperature	-40°C - +85°C								
EMC	EN61000-6-2 (2001) / EN55022 class B (1998) +A1 + A2								
Failure relay	Relay output (30VDC / 1A oder 250AC / 1A)								
Weight	500 g								
Dimensions H x W x D	H: 115 mm B: 61 mm T: 113 mm								
Housing	Stainless steel, powder coated								

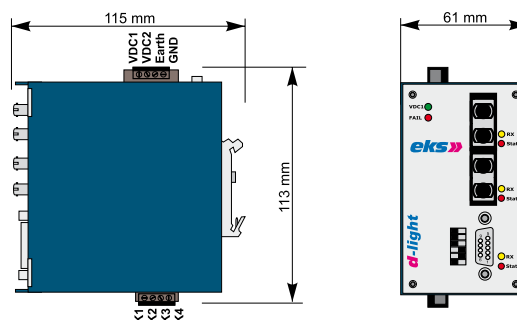

DL-485PB / DL-485PBR

PROFIBUS-Fiber Optic System



fiberview: Monitoring specified system budgets

Via LEDs **fiberview** works similarly to a traffic light. If the "traffic light" is green, everything is fine. If the yellow light is flashing, the budget is still tolerable, but already below a certain system reserve. Additionally to the LED, this pre-warning level is also signaled by a potential-free contact. If the "traffic light" turns red, however, there is a serious error.

System description

The systems DL-485PB connect Profibus-field bus networks by fiber optics. With the help of this innovative system, optical bus, star, tree and mixed structures are possible.

The special multifunctional fiber optic system DL-485PBR also allows the construction of optical ring structures.

The system of this series is especially suitable for applications with strict safety-related requirements as for instance: process industry, tunnel ventilation systems and railway technology.

Important performance features of the transfer with POF, HCS, multimode or singlemode fiber optic are the electromagnetic ruggedness, the potential separation of transmitter and receiver, as well as ranges up to 100km between two fiber optic systems. LEDs and potential-free contacts (optional) of a fault detector relay are able to signal defective states.

In addition to ST, SC and SMA the optical connection type E2000 is also available. All systems can communicate via two fibers as well as via one fiber with the help of the BIDI-technology with SC port.

Please inquire your requested type if it is not listed in the adjoining chart.

Application

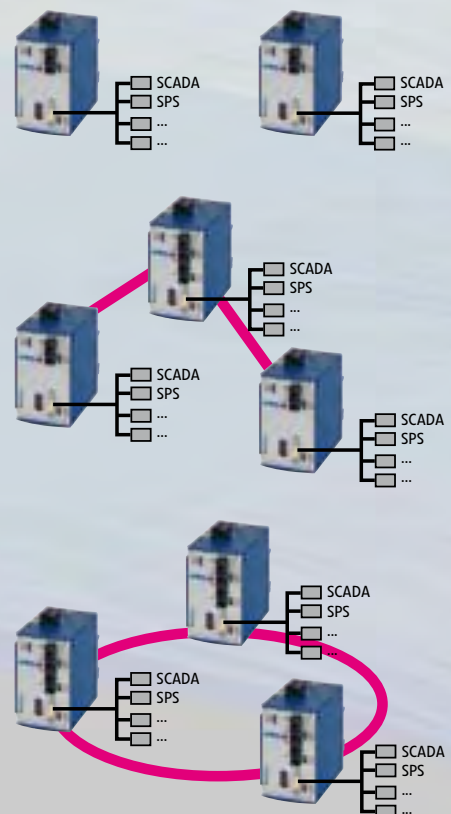

Ordering Information

Type	6-P-ST	6-P-SM	13-MM-ST	13-MM-SC	13-MM-SC /BIDI	13-SM-ST	13-SM-SC	13-SM-E2	13-SM-SC /BIDI
Order no. DL-485PB	0 1000 6201	0 1000 6202	0 1000 6221	0 1000 6223	0 1000 6223-BIDIA 6223-BIDIB	0 1000 6231	0 1000 6233	0 1000 6235	0 1000 6233-BIDI
Order no. DL-485PB/2x	0 1000 6251	0 1000 6252	0 1000 6271	0 1000 6273	0 1000 6273-BIDI	0 1000 6281	0 1000 6283	0 1000 6285	0 1000 6283-BIDI
Order no. DL-485PBR	0 1000 6351	0 1000 6352	0 1000 6371	0 1000 6373	0 1000 6373-BIDI	0 1000 6381	0 1000 6383	0 1000 6385	0 1000 6383-BIDI
FO connector	ST	SMA	ST	SC	SC	ST	SC	E-2000	SC
Fiber	POF 980/1000 µm	HCS 200/230 µm	Multimode 62,5 (50) /125 µm			Singlemode 9/125 µm			
Optical budget	12 dB	15 dB	13 dB			17 dB			
FO range	50 m (180 dB/km)	120 m (10 dB/km)	2,5 km (2 dB/km)			30 km, others up to 100km on request (0,4 dB/km)			
Wavelength	650 nm		1310 nm		1310 nm 1550 nm	1310 nm			1310 nm 1550 nm
Data rate max.	12MBit/s								
Transmission type	Half-duplex								
Signal delay	RS485 ↔ Fiber Optic : < 3 TBit / Tx ↔ Rx : 11 TBit								
Terminating resistor	Switchable: none or wave impedance (Rw + Rpd + Rpu)								
Cable length electr.	1.200m (9,6 – 187,5KBit/s), 400m (500KBit/s), 200m (1.5MBit/s), 100m (3MBit/s - 12MBit/s)								
Connecting plug	9 pole Sub-D female and 6 pole terminal								
Status - LEDs	Power supply (green) / Data (yellow) / Status (red)								
Operating voltage	12-30 VDC, other voltages on request								
Power consumption	200 mA								
Potential separation	500 VDC (24 VDC → Profibus RS485)								
Operating temperature	-40°C - +70°C								
Storage temperature	-40°C - +85°C								
EMC	EN61000-6-2 (2001) / EN55022 class B (1998) +A1 + A2								
Failure relay	Relay output (30VDC / 1A oder 250AC / 1A)								
Weight	500 g								
Dimensions H x W x D	H: 115mm W: 61mm D: 113mm								
Housing	Stainless steel, powder coated								

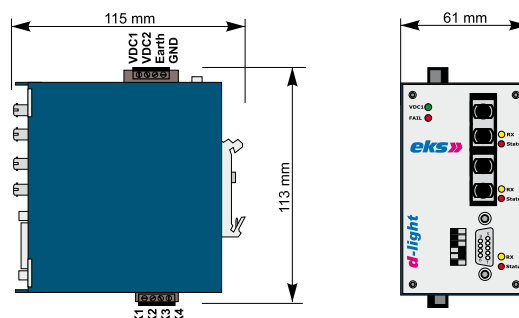

DL-485MBP / DL-MBPR

MODBUS-PLUS-Fiber Optic System



System description

The fiber optic systems DL-485MBP connects a Modbus-Plus interface to an optical field bus networks. With the help of this innovative system optical bus, star, tree and mixed structures are possible.

The special multifunctional fiber optic system DL-MBPR also allows the construction of optical ring structures.

Important performance features of the transfer with POF, HCS, multimode or singlemode fiber optic are the electromagnetic ruggedness, the potential separation of transmitter and receiver, as well as ranges up to 100km between two fiber optic systems. LEDs and potential-free contacts (optional) of a fault detector relay are able to signal defective states.

In addition to ST, SMA and SC the optical connection type E2000 is also available. All systems can communicate via two as well as one fiber with the help of the BIDI-technology with SC port.

Please inquire your requested type if it is not listed in the adjoining chart.

Application

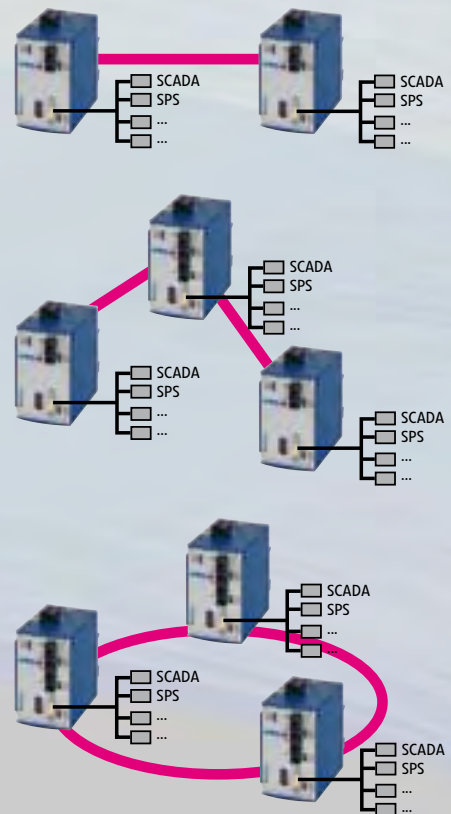

Ordering Information

Type	6-P-ST	6-P-SM	13-MM-ST	13-MM-SC	13-MM-SC /BIDI	13-SM-ST	13-SM-SC	13-SM-E2	13-SM-SC /BIDI
Order no. DL-485MBP	0 1000 6401	0 1000 6402	0 1000 6421	0 1000 6423	0 1000 6423 BIDIA 6423-BIDIB	0 1000 6431	0 1000 6433	0 1000 6435	0 1000 6433-BIDIA 6433-BIDIB
Order no. DL-485MBP/2x	0 1000 6451	0 1000 6452	0 1000 6471	0 1000 6473	0 1000 6473-BIDI	0 1000 6481	0 1000 6483	0 1000 6485	0 1000 6483-BIDI
Order no. DL-485MBPR	0 1000 7951	0 1000 7952	0 1000 7971	0 1000 7973	0 1000 7973-BIDI	0 1000 7981	0 1000 7983	0 1000 7985	0 1000 7983-BIDI
FO connector	ST	SMA	ST	SC	SC	ST	SC	E-2000	SC
Fiber	POF 980/1000 µm	HCS 200/230 µm	Multimode 62,5 (50) /125 µm			Singlemode 9/125 µm			
Optical budget	12 dB	15 dB	13 dB			17 dB			
FO range	50 m (180 dB/km)	120 m (10 dB/km)	5 km (1 dB/km)			30 km, others up to 100km on request (0,4 dB/km)			
Wavelength	650 nm		1310 nm	1310 nm 1550 nm	1310 nm			1310 nm 1550 nm	
Data rate max.	1 Mbit/s								
Transmission type	Half-duplex								
Signal delay	Modbus Plus Interface ↔ Fiber Optic: < 400ns / Tx ↔ Rx : 500ns MBPR : MODBUS Plus Interface ↔ Fiber Optic : < 1µs								
Terminating resistor	According to MODBUS Plus specifications: no terminating resistors in device								
Cable length electr.	50 m								
Connecting plug	9 pole Sub-D female and 6 pole terminal								
Status - LEDs	Power supply (green) / Data (yellow) / Status (red)								
Operating voltage	12-30 VDC, other voltages on request								
Power consumption	200 mA								
Potential separation	500 VDC (24 VDC → Modbus Plus Interface)								
Operating temperature	-40°C - +70°C								
Storage temperature	-40°C - +85°C								
Failure relay	Relay output (30VDC / 1A oder 250AC / 1A)								
EMC	EN61000-6-2 (2001) / EN55022 class B (1998) +A1 + A2								
Weight	500 g								
Dimensions H x W x D	H: 115mm W: 61mm D: 113mm								
Housing	Stainless steel, powder coated								

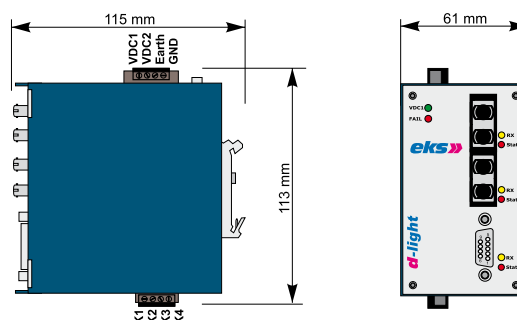

DL-CAN / DL-CANR

CAN-Fiber Optic System



System description

The systems DL-CAN connect CAN field bus networks via fiber optics. With the help of this innovative system, optical bus, star, tree and mixed structures are possible.

The special multifunctional fiber optic system DL-CANR also allows the construction of optical ring structures.

The system of this series is especially suitable for applications with strict safety-related requirements as for instance: process industry, tunnel ventilation systems and railway technology.

Important performance features of the transfer with POF, HCS, multimode or singlemode fiber optic are the electromagnetic ruggedness, the potential separation of transmitter and receiver, as well as ranges up to 100km between two fiber optic systems. LEDs and potential-free contacts (optional) of a fault detector relay are able to signal defective states.

In addition to ST, SC and SMA the optical connection type E2000 is also available. All systems can communicate via two fibers as well as via one fiber with the help of the BIDI-technology with SC port.

Please inquire your requested type if it is not listed in the adjoining chart.

Application

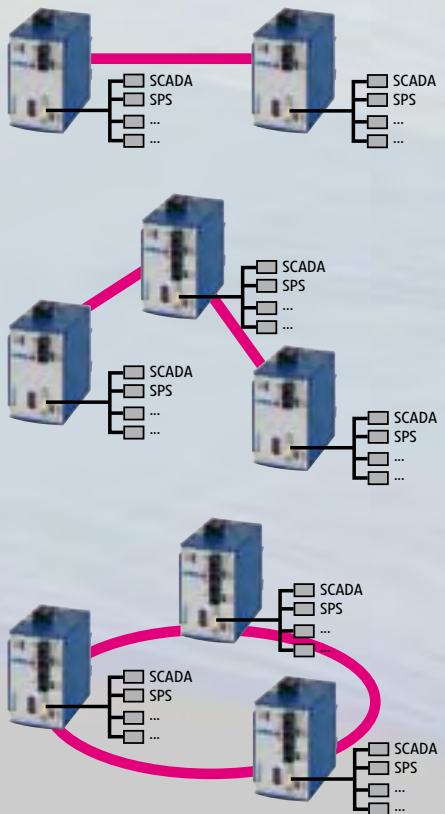

Ordering Information

Type	6-P-ST	6-P-SM	13-MM-ST	13-MM-SC	13-MM-SC /BIDI	13-SM-ST	13-SM-SC	13-SM-E2	13-SM-SC /BIDI
Order no. DL-CAN	0 1000 7401	0 1000 7402	0 1000 7421	0 1000 7423	0 1000 7423-BIDI	0 1000 7431	0 1000 7433	0 1000 7435	0 1000 7433-BIDI
Order no. DL-CAN/2x	0 1000 7451	0 1000 7452	0 1000 7471	0 1000 7473	0 1000 7473-BIDI	0 1000 7481	0 1000 7483	0 1000 7485	0 1000 7483 BIDI
Order no. DL_CANR	0 1000 7551	0 1000 7552	0 1000 7571	0 1000 7573	0 1000 7573 BIDI	0 1000 7581	0 1000 7583	0 1000 7585	0 1000 7583-BIDI
FO connector	ST	SMA	ST	SC	SC	ST	SC	E-2000	SC
Fiber	POF 980/1000 µm		Multimode 62,5 (50) /125 µm			Singlemode 9/125 µm			
Optical budget	12dB		13dB			17dB			
FO range	50 m (180dB/km)		5 km (1 dB/km)			30 km, others up to 100km on request (0,4 dB/km)			
Wavelength	650 nm		1310 nm			1310 nm			
Data rate max.	1000, 800, 500, 250, 125, 100, 50, 22,2, 20 and 20 KBaud switchable with DIP-switch								
Transmission type	Half-duplex								
Terminating resistor	Switchable: none or wave impedance (Rw)								
Cable length electr.	According to CAN-specifications								
Connecting plug	9 pole Sub-D female and 6 pole terminal								
Status - LEDs	Power supply (green) / Data (yellow) / Status (red)								
Operating voltage	12-30 VDC, other voltages on request								
Power consumption	200 mA								
Potential separation	500 VDC (24 VDC → CAN Interface)								
Operating temperature	-40°C - +70°C								
Storage temperature	-40°C - +85°C								
EMC	EN61000-6-2 (2001) / EN55022 class B (1998) +A1 + A2								
Failure relay	Relay output (30VDC / 1A oder 250AC / 1A)								
Weight	500 g								
Dimensions H x W x D	H: 115mm W: 61mm D: 113mm								
Housing	Stainless steel, powder coated								

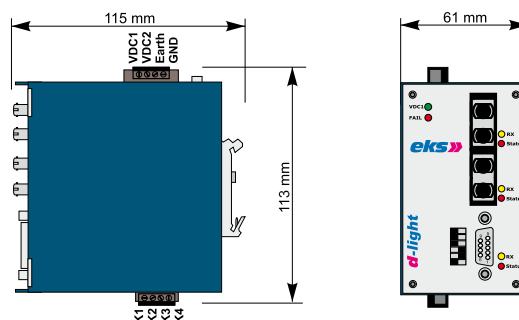

DL-422

RS422-Fiber Optic System



System description

The fiber optic systems DL-422 connect applications with a RS422 interface via fiber optics.

With the help of this innovative system optical bus, star, tree and mixed structures are possible.

Important performance features of the transfer with POF, HCS, multimode or singlemode fiber optic are the electromagnetic ruggedness, the potential separation of transmitter and receiver, as well as ranges up to 100km between two fiber optic systems. LEDs and potential-free contacts (optional) of a fault detector relay are able to signal defective states.

In addition to ST, SMA and SC the optical connection type E2000 is also available. All systems can communicate via two as well as one fiber with the help of the BIDI-technology with SC port.

Please inquire your requested type if it is not listed in the adjoining chart.

Application

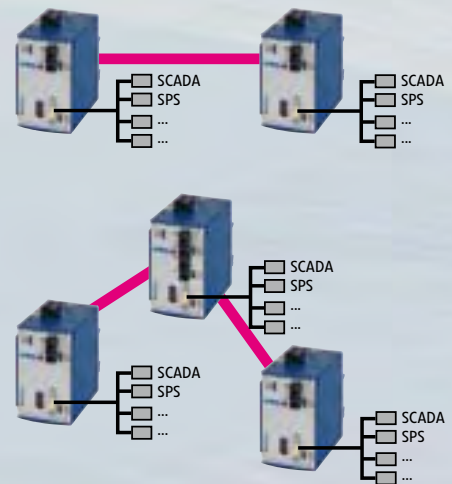

Ordering Information

Type	6-P-ST	6-P-SM	13-MM-ST	13-MM-SC	13-MM-SC /BIDI	13-SM-ST	13-SM-SC	13-SM-E2	13-SM-SC /BIDI
Order no. DL-422	0 1000 2101	0 1000 2102	0 1000 2121	0 1000 2123	0 1000 2123-BIDIA 2123 BIDIB	0 1000 2131	0 1000 2133	0 1000 2135	0 1000 2133 BIDIA 2133 BIDIB
Order no. DL-422/2x	0 1000 2151	0 1000 2152	0 1000 2171	0 1000 2173	0 1000 2173-BIDI	0 1000 2181	0 1000 2183	0 1000 2185	0 1000 2183-BIDI
FO connector	ST	SMA	ST	SC	SC	ST	SC	E-2000	SC
Fiber	POF 980/1000 μm		Multimode 62,5 (50) /125 μm			Singlemode 9/125 μm			
Optical budget	12dB		13dB			17dB			
FO range	50 m (180dB/km)		5 km (1 dB/km)			30 km, others up to 100km on request (0,4 dB/km)			
Wavelength	650 nm		1310 nm		1310nm 1550nm	1310 nm			1310nm 1550nm
Data rate max.	1,5Mbit/s (divided by number of connectors)								
Transmission type	Duplex, half-duplex with DL-422/2x								
Terminating resistor	switchable: none or pull-up resistor (Rp) or wave impedance (Rw)								
Cable length electr.	50 m								
Connecting plug	9 pole Sub-D female and 6 pole terminal								
Status - LEDs	Power supply (green) / Data (yellow) / Status (red)								
Operating voltage	12-30 VDC, other voltages on request								
Power consumption	200 mA								
Potential separation	500 VDC (24 VDC → RS422)								
Operating temperature	-40°C - +70°C								
Storage temperature	-40°C - +85°C								
EMC	EN61000-6-2 (2001) / EN55022 class B (1998) +A1 + A2								
Weight	500 g								
Dimensions H x W x D	H: 115mm W: 61mm D: 113mm								
Housing	Stainless steel, powder coated								

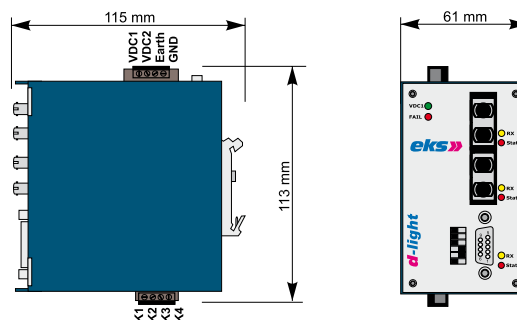

DL-232 / DL-232R

RS232-Fiber Optic System



System description

The fiber optic systems DL-232 connect systems with a RS232-interface via fiber optics. The DL-232 allows communication via software-handshake (Xon/ Xoff). With the help of this innovative system optical bus, star, tree and mixed structures are possible.

The special multifunctional fiber optic system DL-232R also allows the construction of optical ring structures.

Important performance features of the transfer with POF, HCS, multimode or singlemode fiber optic are the electromagnetic ruggedness, the potential separation of transmitter and receiver, as well as ranges up to 100km between two fiber optic systems. LEDs and potential-free contacts (optional) of a fault detector relay are able to signal defective states.

Furthermore RS232- fiber optic systems are also available in the following designs:



Application

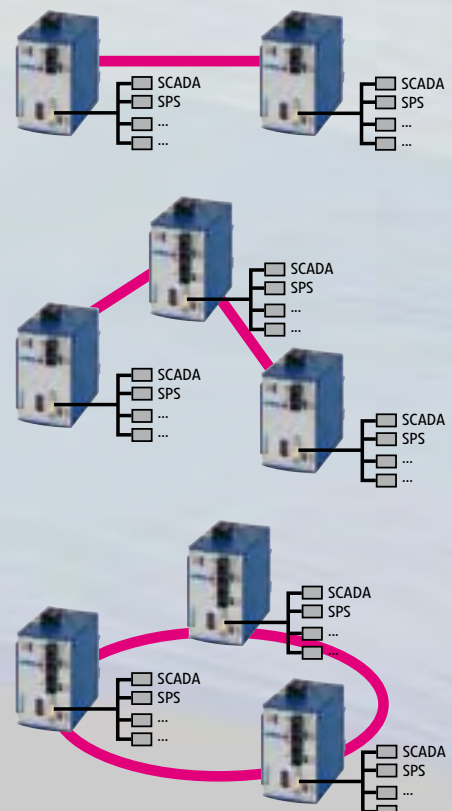

Ordering Information

Type	6-P-ST	6-P-SM	13-MM-ST	13-MM-SC	13-MM-SC /BIDI	13-SM-ST	13-SM-SC	13-SM-E2	13-SM-SC /BIDI
Order no. DL-232	0 1000 1101	0 1000 1102	0 1000 1121	0 1000 1123	0 1000 1123-BIDIA 1123-BIDIB	0 1000 1131	0 1000 1133	0 1000 1135	0 1000 1133-BIDIA 1133-BIDIB
Order no. DL-232/2x	0 1000 1151	0 1000 1152	0 1000 1171	0 1000 1173	0 1000 1173-BIDI	0 1000 1181	0 1000 1183	0 1000 1185	0 1000 1183-BIDI
Order no. DL-232R	0 1000 1351	0 1000 1352	0 1000 1371	0 1000 1373	0 1000 1373-BIDI	0 1000 1381	0 1000 1383	0 1000 1385	0 1000 1383-BIDI
FO connector	ST	SMA	ST	SC	SC	ST	SC	E-2000	SC
Fiber	POF 980/1000 μm		Multimode 62,5 (50) /125 μm			Singlemode 9/125 μm			
Optical budget	12 dB		13 dB			17 dB			
FO range	50 m (180dB/km)		2,5 km (2 dB/km)			30 km, others up to 100km on request (0,4 dB/km)			
Wavelength	650 nm		1310 nm		1310nm 1550nm	1310 nm			1310nm 1550nm
Data rate max.	115,2 Kbit/s								
Transmission type	duplex, half-duplex with DL-232/2x and DL-232R								
Operation type	DTE or DCE switchable with DIP-switch								
Cable length electr.	15 m								
Connecting plug	9 pole Sub-D female and 6 pole terminal								
Status - LEDs	Power supply (green) / Data (yellow) / Status (red)								
Operating voltage	12-30 VDC, other voltages on request								
Power consumption	200 mA								
Potential separation	500 VDC (24 VDC → RS232)								
Operating temperature	-40°C - +70°C								
Storage temperature	-40°C - +85°C								
EMC	EN61000-6-2 (2001) / EN55022 class B (1998) +A1 + A2								
Failure relay	Relay output (30VDC / 1A oder 250AC / 1A)								
Weight	500 g								
Dimensions H x W x D	H: 115mm W: 61mm D: 113mm								
Housing	Stainless steel, powder coated								

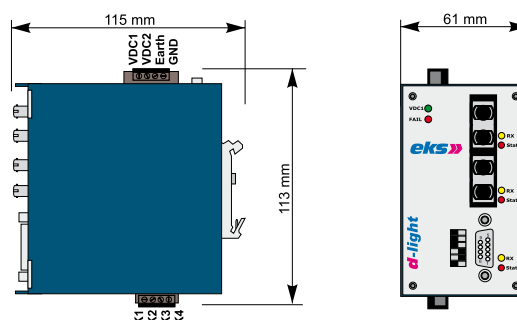

DL-232MUX

RS232-Multiplexer-Fiber Optic System



System description

The system DL-RS232MUX is a multiplexer for 4xRS232 signals, working bidirectionally via fiber optics. Thus, in addition to the RxD and TxD signals, hardware-handshake signals as RTS, CTS, DCD, DSR and DTR can be transferred, too.

RS232-multiplexers have a similar pin assignment as modems. Two multiplexers, connected by fiber optics, cross the wires and operate like a null modem cable.

Hence, connecting two data processing terminals (with pin assignment) requires two 1:1 cables to be able to link the terminals to the multiplexers. Terminals with a DCE-pin assignment have to be connected to the multiplexer via a null modem cable.

Important performance features of the transfer with POF, HCS, multimode or singlemode fiber optic are the electromagnetic ruggedness, the potential separation of transmitter and receiver, as well as ranges up to 100km between two fiber optic systems. LEDs and potential-free contacts (optional) of a fault detector relay are able to signal defective states.

In addition to ST and SC the optical connection type E2000 is also available. All systems can communicate via two as well as one fiber with the help of the BIDI-technology with SC port.

Please inquire your requested type if it is not listed in the adjoining chart.

Application



Ordering Information

Type	6-P-ST	6-P-SM	13-MM-ST	13-MM-SC	13-MM-SC /BIDI	13-SM-ST	13-SM-SC	13-SM-E2	13-SM-SC /BIDI
Order no. DL-232MUX	0 1000 1201	0 1000 1202	0 1000 1221	0 1000 1223	0 1000 1223 BIDIA 1223-BIDIB	0 1000 1231	0 1000 1233	0 1000 1235	0 1000 1233-BIDIA 1233-BIDIB
FO connector	ST	SMA	ST	SC	SC	ST	SC	E-2000	SC
Fiber	POF 980/1000 μm		Multimode 62,5 (50) /125 μm			Singlemode 9/125 μm			
Optical budget	12dB		13dB			17dB			
FO range	50 m (180dB/km)		2,5 km (2 dB/km)			30 km, others up to 100km on request (0,4 dB/km)			
Wavelength	650 nm		1310 nm		1310nm 1550nm	1310 nm			1310nm 1550nm
Data rate max.	115,2KBit/s								
Transmission type	duplex								
Operation type	DTE or DCE switchable with DIP-switch								
Cable length electr.	15 m								
Connecting plug	9 pole Sub-D female								
Status - LEDs	Power supply (green) / Data (yellow) / Status (red)								
Operating voltage	12-30 VDC, other voltages on request								
Power consumption	200 mA								
Potential separation	500 VDC (24 VDC → RS232)								
Operating temperature	-40°C - +70°C								
Storage temperature	-40°C - +85°C								
EMC	EN61000-6-2 (2001) / EN55022 class B (1998) +A1 + A2								
Weight	500 g								
Dimensions H x W x D	H: 115mm W: 61mm D: 113mm								
Housing	Stainless steel, powder coated								

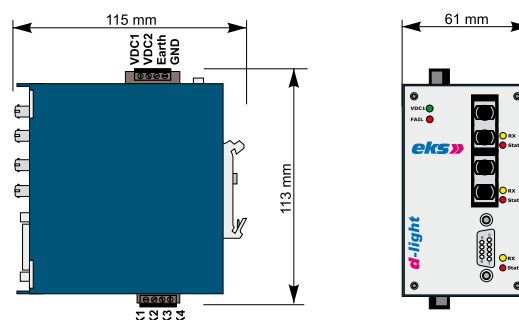

DL-TTY

TTY-Fiber Optic System



System description

The system DL-TTY forms an asynchronous TTY- interface (20mA active, half-active or passive) which can be operated in two ways: either half-duplex or full-duplex.

Important performance features of the transfer with POF, HCS, multimode or singlemode fiber optic are the electromagnetic ruggedness, the potential separation of transmitter and receiver, as well as ranges up to 10km between two fiber optic systems. LEDs and potential-free contacts (optional) of a fault detector relay are able to signal defective states.

In addition to ST and SC the optical connection type E2000 is also available. All systems can communicate via two as well as one fiber with the help of the BIDI-technology with SC port.

Please inquire your requested type if it is not listed in the adjoining chart.

Application



Ordering Information

Type	6-P-ST	6-P-SM	13-MM-ST	13-MM-SC	13-MM-SC /BIDI	13-SM-ST	13-SM-SC	13-SM-E2	13-SM-SC /BIDI
Order no. DL-TTY	0 1000 4101	0 1000 4102	0 1000 4121	0 1000 4123	0 1000 4123 BIDIA 4123-BIDIB	0 1000 4131	0 1000 4133	0 1000 4135	0 1000 4133-BIDIA 4133-BIDIB
FO connector	ST	SMA	ST	SC	SC	ST	SC	E-2000	SC
Fiber	POF 980/1000 μm		Multimode 62,5 (50) /125 μm			Singlemode 9/125 μm			
Optical budget	12dB		13dB			17dB			
FO range	50 m (180dB/km)		2,5 km (2 dB/km)			30 km, others up to 100km on request (0,4 dB/km)			
Wavelength	650 nm		1310 nm		1310nm 1550nm	1310 nm			1310nm 1550nm
Data rate max.	19,2 KBit/s								
Loop current	2 x 20 mA								
Load	< 100 Ohm								
Operation type	duplex: aktive, half-active or passive / Half-duplex: aktive or passive								
Connecting plug	9 pole Sub-D female and 6 pole terminal								
Status - LEDs	Power supply (green) / Data (yellow) / Status (red)								
Operating voltage	12-30 VDC, other voltages on request								
Power consumption	200 mA								
Potential separation	500 VDC (24 VDC → TTY)								
Operating temperature	-40°C - +70°C								
Storage temperature	-40°C - +85°C								
EMC	EN61000-6-2 (2001) / EN55022 class B (1998) +A1 + A2								
Weight	500 g								
Dimensions H x W x D	H: 115mm W: 61mm D: 113mm								
Housing	Stainless steel, powder coated								

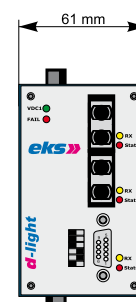
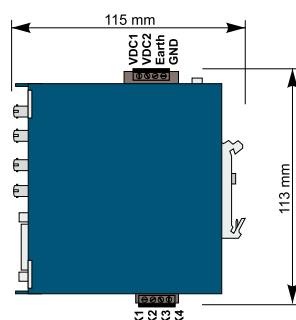

DL-LWV

Media Converter and Optical Amplifier



System description

The fiber optic system DL-LWV works as amplifier and media converter for several fiber optic transmission networks.

Less optical power requires amplification. Different fiber types within one application need conversion. The system DL-LWV offers various possibilities, corresponding to these requirements.

The system contains fiber optic receiver and transmitter components. The incoming signal is electrically processed, amplified and then coupled back into the fiber optic cable via the transmitter. With the aid of this intermediate amplifier the line length is unlimited using various fiber types as for instance: POF, HCS, multimode or singlemode fiber optic cable.

LEDs and potential-free contacts (optional) of a fault detector relay are able to signal defective states.

Please note that the adjoining chart just covers a small selection of our product range. In general, any combination of fiber type, wavelength and bandwidth is available. The columns are marked with F1 up to F16 for the types of fiber.

In addition to ST, SMA and SC the optical connection types E2000 and the HP Versatile Link are also available. All systems can communicate via two as well as one fiber with the help of the BIDI-technology with SC port.

Please inquire your requested type if it is not listed in the adjoining chart.

Application

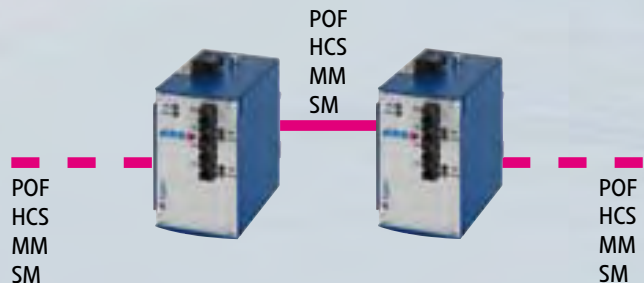

Ordering Information

FO interface	F1	F2	F3	F4	F5	F6	F7	F8	F9	F10	F11	F12	F13	F14	F15	F16	
FO connector	HP VL	HP VL	ST	SMA	ST	SMA	ST	SC	ST	SC	SC BIDI	E-2000	ST	SC	SC BIDI	E-2000	
Fiber	POF 980/1000µm				POF 980/1000µm			Multimode 62,5 (50) /125µm				Singlemode 9/125µm					
Optical budget	29 dB	12 dB	12 dB	12 dB	12 dB			8 (4,2) dB		13 dB			17 dB				
Data rate max.	57,6 KBits	10 MBits	5 MBit/s		100 MBit/s			5 MBit/s		100 MBit/s			100 MBit/s				
FO range	150m	40 m			40 m			2,6 (1,4) km		5 km			30 km, others up to 100km on request				
Fiber attenuation	180 dB/km						3 dB/km		1 dB/km			0,4 dB/km					
Wavelength	650 nm						820 nm		1310 nm			1310 nm					
Status - LEDs	Power supply (green) / Data (yellow) / Status (red)																
Operating voltage	12-30 VDC, other voltages on request																
Power consumption	200 mA																
Potential separation	500 VDC																
Operating temperature	-10°C - +55°C																
Storage temperature	-40°C - +85°C																
EMC	EN61000-6-2 (2001) / EN55022 class B (1998) +A1 + A2																
Failure relay	Relay output (30VDC / 1A oder 250AC / 1A)																
Weight	500 g																
Dimensions H x W x D	H: 115mm W: 61mm D: 113mm																
Housing	Stainless steel, powder coated																

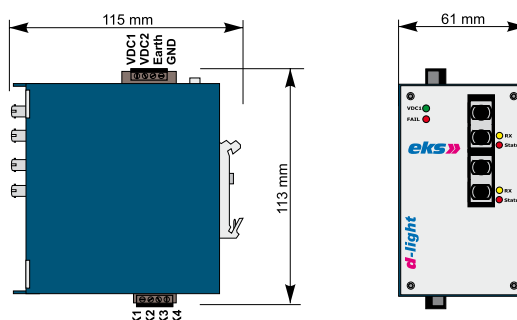

IOL-3000

Analog- and Digital-Signal Fiber-Optic-System



System description

The fiber optic system IOL-3000 transmits digital signals (e.g., contact closures, control-signals) and analog signals via fiber optics.

The fiber optic cable is able to transmit up to 8 digital signals (12-24VDC) and/ or 4 analog signals (0-10V or 0-20mA, digitalized via A/D converter with a resolution of 10 Bit) within a point-to-point structure or line-structure.

Important performance features of the transfer with POF, HCS, multimode or singlemode fiber optic are the electromagnetic ruggedness, the potential separation of transmitter and receiver, as well as ranges up to 100km between two fiber optic systems. LEDs and a potential-free contact of a fault detector relay are able to signal defective states.

In addition to ST and SC the optical connection type E2000 is also available. All systems can communicate via two as well as one fiber with the help of the BIDI-technology with SC port.

Please inquire your requested type if it is not listed in the adjoining chart.

Application

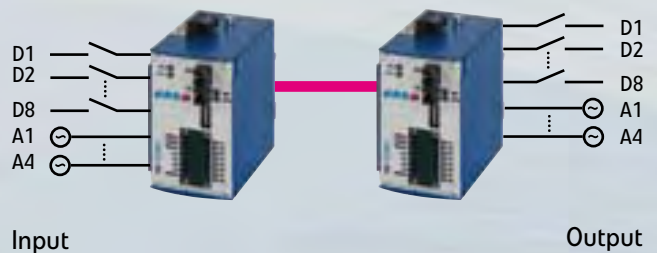

Ordering Information

Type	6-P-ST	6-P-SM	13-MM-ST	13-MM-SC	13-MM-SC /BIDI	13-SM-ST	13-SM-SC	13-SM-E2	13-SM-SC /BIDI
Type Transmitter IOL-3000									
Order no. 4 x Analogue 0-10V	0 3000 1101	0 3000 1102	0 3000 1121	0 3000 1123	0 3000 1123 BIDIA	0 3000 1131	0 3000 1133	0 3000 1135	0 3000 1133-BIDIA
Order no. 4 x Analogue 0-10 V 8 x Digital 12 – 24 VDC	0 3000 1201	0 3000 1202	0 3000 1221	0 3000 1223	0 3000 1223 BIDIA	0 3000 1231	0 3000 1233	0 3000 1235	0 3000 1233-BIDIA
Order no. 8 x Digital 12 – 24 VDC	0 3000 1301	0 3000 1302	0 3000 1321	0 3000 1323	0 3000 1323 BIDIA	0 3000 1331	0 3000 1333	0 3000 1335	0 3000 1333-BIDIA
Order no. 4 x Analogue 0-20 mA 8 x Digital 12 – 24 VDC	0 3000 1401	0 3000 1402	0 3000 1421	0 3000 1423	0 3000 1423 BIDIA	0 3000 1431	0 3000 1433	0 3000 1435	0 3000 1433-BIDIA
Order no. 4 x Analogue 0-20 mA	0 3000 1501	0 3000 1502	0 3000 1521	0 3000 1523	0 3000 1523-BIDIA	0 3000 1531	0 3000 1533	0 3000 1535	0 3000 1533-BIDIA
Type Receiver IOL-3000									
Order no. 4 x Analogue 0-10V (0,2%)	0 3000 2101	0 3000 2102	0 3000 2121	0 3000 2123	0 3000 2123 BIDIA	0 3000 2131	0 3000 2133	0 3000 2135	0 3000 2133-BIDIA
Order no. 4 x Analogue 0-10 V 8 x Digital 12-24 VDC / -IR	0 3000 2201	0 3000 2202	0 3000 2221	0 3000 2223	0 3000 2223 BIDIA	0 3000 2231	0 3000 2233	0 3000 2235	0 3000 2233-BIDIA
Order no. 8 x Digital 12-24 VDC / -IR	0 3000 2301	0 3000 2302	0 3000 2321	0 3000 2323	0 3000 2323 BIDIA	0 3000 2331	0 3000 2333	0 3000 2335	0 3000 2333-BIDIA
Order no. 4 x Analogue 0-20 mA (0,2%) 8 x Digital 24 VDC / -IR	0 3000 2401	0 3000 2402	0 3000 2421	0 3000 2423	0 3000 2423 BIDIA	0 3000 2431	0 3000 2433	0 3000 2435	0 3000 2433-BIDIA
Order no. 4 x Analogue 0-20 mA (0,2%)	0 3000 2501	0 3000 2502	0 3000 2521	0 3000 2523	0 3000 2523-BIDIA	0 3000 2531	0 3000 2533	0 3000 2535	0 3000 2533-BIDIA
FO connector	ST	SMA	ST	SC	SC	ST	SC	E-2000	SC
Fiber	POF 980/1000 µm		Multimode 62,5 (50) /125 µm			Singlemode 9/125 µm			
Optical budget	12dB		8dB			17dB			
FO range	50 m (180dB/km)		5 km (1 dB/km)			30 km, others up to 100km on request (0,4 dB/km)			
Wavelength	650 nm		1310 nm			1310 nm			
Status - LEDs	Power supply (green) / Data (yellow) / Status (red)								
Operating voltage	24 VDC (10 VDC ... 30 VDC), other voltages on request								
Cable length electr.	1 m								
Power consumption	200 mA								
Potential separation	500 VDC								
Operating temperature	-10°C - +55°C								
Storage temperature	-40°C - +85°C								
EMC	EN61000-6-2 (2001) / EN55022 class B (1998) +A1 + A2								
Failure relay	Relay output (30VDC / 1A oder 250AC / 1A)								
Weight	500 g								
Dimensions H x W x D	H: 115mm W: 61mm D: 113mm								
Housing	Stainless steel, powder coated								

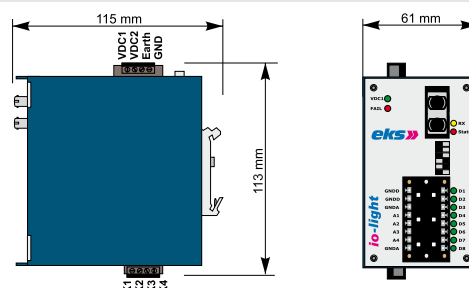

IOL-3100

Digital-Signal Fiber-Optic-System Bi-Directional



System description

The fiber optic system IOL-3100 transmits digital signals (e.g., contact closures, control-signals) bi-directional via fiber optics.

Using addressed subscribers, the fiber optic cable is able to transmit up to 4 digital signals (12-24VDC) in a point-to-point structure.

Important performance features of the transfer with POF, HCS, multimode or singlemode fiber optic are the electromagnetic ruggedness, the potential separation of transmitter and receiver, as well as ranges up to 100km between two fiber optic systems. LEDs and a potential-free contact of a fault detector relay are able to signal defective states.

In addition to ST and SC the optical connection type E2000 is also available. All systems can communicate via two as well as one fiber with the help of the BIDI-technology with SC port.

Please inquire your requested type if it is not listed in the adjoining chart.

Application

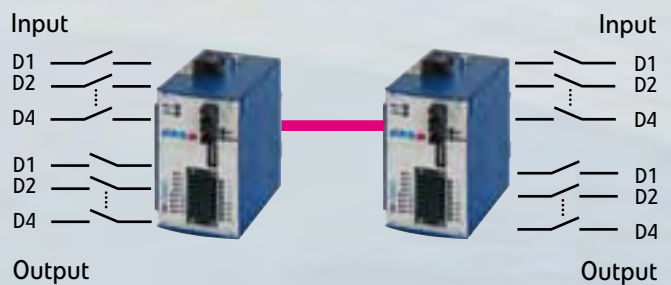

Ordering Information

Type	6-P-ST	6-P-SM	13-MM-ST	13-MM-SC	13-MM-SC /BIDI	13-SM-ST	13-SM-SC	13-SM-E2	13-SM-SC /BIDI
Order no. IOL-3100 4 x Digital TRX	0 3100 2301	0 3100 2302	0 3100 2321	0 3100 2323	0 3100 2323-BIDIA 2323-BIDIB	0 3100 2331	0 3100 2333	0 3100 2335	0 3100 2333-BIDIA 2333-BIDIB
FO connector	ST	SMA	ST	SC	SC	ST	SC	E-2000	SC
Fiber	POF 980/1000 μm		Multimode 62,5 (50) /125 μm			Singlemode 9/125 μm			
Optical budget	12 dB		13 dB			17 dB			
FO range	50 m (180 dB/km)		5 km (1 dB/km)			30 km, others up to 100km on request (0,4 dB/km)			
Wavelength	650 nm		1310 nm		1310 nm 1550 nm	1310 nm			1310 nm 1550 nm
Signal Input	12 – 24 VDC / 5 mA								
Signal Output	30VDC / 1A or 250VAC / 1 Relay contact								
Cable length electr.	1 m								
Connecting plug	16 pole terminal								
Status - LEDs	Power supply (green) / Data (yellow) / Status (red)								
Operating voltage	12-30 VDC, other voltages on request								
Power consumption	200 mA								
Potential separation	500 VDC								
Operating temperature	-10°C - +55°C								
Storage temperature	-40°C - +85°C								
EMC	EN61000-6-2 (2001) / EN55022 class B (1998) +A1 + A2								
Failure relay	Relay output (30VDC / 1A oder 250AC / 1A)								
Weight	500 g								
Dimensions H x W x D	H: 115mm W: 61mm D: 113mm								
Housing	Stainless steel, powder coated								

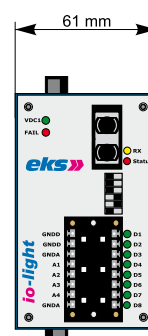
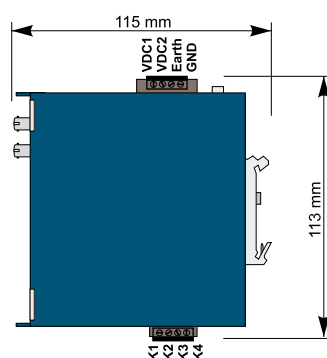

DragonLine

Ethernet Systems Series DragonLine



System description

DragonLine ist separate product range It consists of un-managed and managed Switches for Fast-Ethernet or Gigabit-Ethernet in industrial areas or at SOHO applications, additional with PoE (Power over Ethernet). The systems can be mounted on DIN RAIL's, racks or chassis as well as on walls. Furthermore Device- or COM-Server for RS232-, RS422- and RS485 interfaces are available.

Important performance features of the transfer with multimode or singlemode fiber optic are the electromagnetic ruggedness, the potential separation of transmitter and receiver, as well as ranges up to 40km between two fiber optic systems. LED's and potential-free contacts of a fault detector relay are able to signal defective states.

Additional features are autonegotiation, MDX/ MDIX and redundant power supply with an input voltage range from 19VDC to 60VDC.

Furthermore the system is characterized by high temperature ranges and fast reconfiguration times of the redundant ring. The management-software, an IP configuration tool based on Windows, is provided free of charge so that no additional costs incur.



DragonLine Switch Media Converter

1x10/100TX to 100FX and 1x10/100/1000TX to 1000FX



	10/100 TX to 100FX	10/100/1000TX to 1000FX
Standard	IEEE802.3 10BASE-T IEEE802.3x Flow Control and Back pressure IEEE802.3u 100BASE-TX/100BASE-FX	IEEE802.3 10BASE-T IEEE802.3u 100BASE-TX IEEE 802.3ab 1000BaseT, IEEE 802.3z 1000BaseSX/LX standards IEEE802.3x Flow Control and Back pressure
Connector	Fiber: Duplex SC RJ-45 Socket: CAT-3/5 (10/100Mbps or 10/100/1000Mbps) Twisted Pair cable Auto MDI/MDI-X and Auto-Negotiation Function Support	
Switch architecture	Store and Forward	
Fiber parameters	Fiber Core: MM (62.5/125 μ m, 50/125 μ m) SM (9/125 μ m) Wavelength: 1310nm(Multimode) 1310nm(Singlemode) Fiber Distance: 2km Multimode 30km Singlemode	Fiber Core: MM(62.5/125 μ m, 50/125 μ m) SM (9/125 μ m) Wavelength: 850nm(Multimode) 1310nm(Singlemode) Fiber Distance: 550m (Multimode) 10km (Singlemode)
Transparent packet size	64 to 1600 Bytes	
Link Loss Forward	TX \rightarrow Fiber: If TX port link down, then converter will forced fiber to link down Fiber \rightarrow TX: If Fiber port link down, the media converter will force TX port to link down	
DIP Switch	DIP Switch 1: UTP Auto-Negotiation/100Mbps Full Duplex mode DIP Switch 2: Fiber Full/Half Duplex DIP Switch 3: LLF (Link Lose Forwarding) & LFP (Link Fault Pass-Through) Disable/Enable DIP Switch 4: Switch Converter/Pure Converter mode	
LED	Module: Power, TX (100Mbps, LK/ACT, FDX/COL) Fiber (LK/ACT, FDX/COL)	
Power	Stand-alone (External Adapter): DC9V/0.7A Chassis Cabinet: AC 100~240 V, 50/60 HZ, 90W*2	
Operation Temp.	0°C to 45°C	
Operation Humidity	10% to 90% (Non-condensing)	
Storage Temp.	-40°C to 70°C	
Dimension	Module: 119mm x 85mm x 26mm Multi-Converter Chassis: 440mm x 266mm x 133 mm (3U, 19")	
EMI	FCC Class A, CE	
Safety	UL, cUL	

Part Number	Description
26000421	10/100Base TX to 100 Base FX (MM/SC/2KM)
26000451	10/100Base TX to 100 Base FX (SM/SC/30KM)

Part Number	Description
261000421	10/100/1000 Base-TX to 1000Base-SX (MM/SC/550m)
261000451	10/100/1000 Base-TX to 1000Base-LX (SM/SC/10km)

DragonLine Media Converter

1x10/100TX to 100FX and 1x10/100/1000TX to 1000FX



	10/100 TX to 100FX	10/100/1000TX to 1000FX
Standard	IEEE802.3 10BASE-T IEEE802.3u 100BASE-TX/100BASE-FX IEEE802.3x Flow Control and Back pressure	IEEE802.3 10BASE-T IEEE802.3u 100BASE-TX/100BASE-FX IEEE802.3ab 1000Base-T IEEE802.3x Flow Control and Back pressure IEEE802.3z 1000BaseSX/LX standards
Switch Architecture	Store and Forward	
Fiber parameters	Fiber Core: MM (62.5/125µm, 50/125µm) SM (9/125µm) Wavelength: 1310nm(Multimode) 1310nm(Singlemode) Fiber Distance: 2km Multimode 30km Singlemode	Fiber Core: MM(62.5/125µm, 50/125µm) SM (9/125µm) Wavelength: 850nm(Multimode) 1310nm(Singlemode) Fiber Distance: 550m (Multimode) 10km (Singlemode)
Link Lose Forward	TX →Fiber: If TX port link down, the media converter will force Fiber port to link down Fiber →TX: If Fiber port link down, the media converter will force TX port to link down	
Connector	Fiber: SC (Multimode, 2km), SC (Singlemode, 30km) RJ-45 Socket: CAT-3/5 (10/100Mbps) Twisted Pair cable Auto MDI/MDI-X and Auto-Negotiation Function Support	
LED	Per unit: Power 1 (Green), Power 2 (Green), Fault(Red) TX: Link/Active (Green), 100M(Yellow) Fiber: Link/Active (Green), Full duplex/Collision (Yellow)	
Power Supply	DC 12~48V / Redundant power with polarity reverse protect and removable terminal block	
Power Consumption	2.74 Watt	5,19 Watt
Operating Humidity	5%~95% (Non-condensing)	
Operating Temperature	Standard: -10°C~60°C Wide Operating Temperature -40°C~75°C	
Storage Temperature	-40°C~85°C	
Case Dimension	Metal case. IP-30, 30mm (W) x 95mm (D) x 140mm (H)	
Installation	DIN Rail and Wall Mount Design	
EMI	FCC Class A, CE EN61000-4-2 (ESD), CE EN61000-4-3 (RS), CE EN-61000-4-4 (EFT), CE EN61000-4-5 (Surge), CE EN61000-4-6 (CS), CE EN61000-4-8, CE EN61000-4-11, CE EN61000-4-12, CE EN61000-6-2, CE EN61000-6-4	
Safety	UL, cUL, CE/EN60950-1	
Stability Testing	IEC60068-2-32 (Free fall), IEC60068-2-27 (Shock), IEC60068-2-6 (Vibration)	

Order Number	Description
26170201	10/100TX to 100FX (SC/MM/2km)
26170251	10/100TX to 100FX (SC/SM/30km)
26170201E	10/100TX to 100FX (SC/MM/2km) -40°C~75°C
26170251E	10/100TX to 100FX (SC/SM/30km) -40°C~75°C

Part Number	Description
261170201E	10/100/1000T to 1000SX (SC/MM/550m) -40°C~75°C
261170251E	10/100/1000T to 1000LX (SC/SM/10km) -40°C~75°C

DragonLine Switch Unmanaged

5x10/100TX and 8x10/100TX



IEEE Standard	IEEE 802.3 10Base-T Ethernet IEEE 802.3u 100Base-TX
Switch Architecture	Back-plane (Switching Fabric): 1Gbps (full-duplex): 1.49Mpps @64bytes
Transfer Rate	14,880pps for Ethernet port 148,800pps for Fast Ethernet port
Packet Buffer	1Mbits
Mac Address	2K MAC address table
Connector	10/100TX: RJ-45 with auto MDI/MDI-X function
Network Cable	10Base-T: 2-pair UTP/STP Cat. 3, 4, 5 cable EIA/TIA-568 100-ohm (100m) 100Base-TX: 2-pair UTP/STP Cat. 5/ 5E cable EIA/TIA-568 100-ohm (100m)
Protocol	CSMA/CD
LED	Per unit: Power 1 (Green), Power 2 (Green), Fault (Red) 5 port 10/100: Link/Activity (Green), Full duplex/Collision (Yellow)
Protection	Power Reverse Present Overload Current Re-settable Fuse Present
Power Supply	DC 10 ~48V or 18~30 VAC, Redundant power with polarity reverse protect function and removable terminal block.
Power Consumption	2.78 Watt / 4.71 Watt
Operating Humidity	5% to 95% (Non-condensing)
Operating Temperature	0°C to 60°C (32°F to 140°F) / Wide Operating Temperature (-40°C~75°C)
Storage Temperature	-40°C to 85°C
Case Dimension	Metal case. IP-30, Metal housing 25mm (W) x 95mm (D) x 130mm (H)
Installation	DIN rail and wall mount ear
EMI	FCC Class A, CE EN61000-4-2, CE EN61000-4-3, CE EN-61000-4-4, CE EN61000-4-5, CE EN61000-4-6, CE EN61000-4-8, CE EN61000-4-11
Safety	UL, cUL, CE/EN60950-1
Stability Testing	IEC60068-2-32 (Free fall), IEC60068-2-27 (Shock), IEC60068-2-6 (Vibration)

Part Number	Description
26670100A2	5x10/100TX
26670100A2E	5x10/100TX -40°C~+75°C
26870200	8x10/100TX
26870200E	8x10/100TX -40°C~+75°C

DragonLine Switch Unmanaged

4x10/100TX + 1x100FX and 4x10/100TX + 2x100FX



IEEE Standard	IEEE 802.3 10Base-T Ethernet IEEE 802.3u 100Base-TX and 100Base-FX Fast Ethernet IEEE802.3x Flow Control and Back Pressure
Switch Architecture	Back-plane (Switching Fabric): 1Gbps Packet throughput ability (Full-Duplex): 1.49Mpps @64bytes
Transfer Rate	14,880pps for Ethernet port / 148,800pps for Fast Ethernet port
Memory Buffer	448Kbits
MAC Address	2K MAC address table
Connector	10/100TX: 4 x RJ-45 with auto MDI/MDI-X function 100m fiber: SC type connector for Singlemode or Multimode type fiber cable
Network Cable	10Base-T: 2-pair UTP/STP Cat. 3, 4, 5 cable / EIA/TIA-568 100-ohm (100m) 100Base-TX: 2-pair UTP/STP Cat. 5 cable / EIA/TIA-568 100-ohm (100m)
Optical Cable	Multimode: 50/125µm~62.5/125µm Singlemode: 9/125µm Available distance: 2km (Multimode)/30km (Singlemode) Wavelength: 1310nm (Multimode/Singlemode)
Protocol	CSMA/CD
LED	Per unit: Power 1 (Green), Power 2 (Green), Fault(Red) Per port: Link/Activity (Green), Full duplex/Collision (Yellow)
Power Supply	12~48 VDC or 18~30 VAC Redundant power with polarity reverse protect function and removable terminal block
Power Consumption	4.44 Watt / 6.41 Watt
Operating Humidity	5%~95% (Non-condensing)
Operating Temperature	Standard -10°C~60°C / Wide Operating Temperature -40°C~75°C
Storage Temperature	-40°C~85°C
Case Dimension	Metal case. IP-30, 25mm (W) x 95mm (D) x 130mm (H)
Installation	DIN Rail and Wall Mount Design
EMI	FCC Class A, CE EN61000-4-2 (ESD), CE EN61000-4-3 (RS), CE EN-61000-4-4 (EFT), CE EN61000-4-5 (Surge), CE EN61000-4-6 (CS), CE EN61000-4-8, CE EN61000-4-11, CE EN61000-4-12, CE EN61000-6-2, CE EN61000-6-4
Safety	UL, cUL, CE/EN60950-1
Stability Testing	IEC60068-2-32 (Free fall), IEC60068-2-27 (Shock), IEC60068-2-6 (Vibration)

Part Number	Description
26470201	4x10/100 TX + 1FX (SC/MM/2km)
26470201E	4x10/100 TX + 1FX (SC/MM/2km) -40°C~+75°C
26470251	4x10/100 TX + 1FX (SC/SM/30km)
26470251E	4x10/100 TX + 1FX (SC/SM/30km) -40°C~+75°C
26470202	4x10/100TX + 2x100FX (SC/MM/2km)
26470202E	4x10/100TX + 2x100FX (SC/MM/2km) -40°C~+75°C
26470252	4x10/100TX + 2x100FX (SC/SM/30km)
26470252E	4x10/100TX + 2x100FX (SC/SM/30km) -40°C~+75°C

DragonLine Switch Unmanaged

5x10/100/1000TX and 8x10/100/1000TX



IEEE Standard	IEEE 802.3 10Base-T IEEE 802.3u 100Base-TX IEEE 802.3ab 1000Base-T IEEE802.3x Flow Control and Back Pressure
Switch Architecture	Back-plane (Switching Fabric): 10Gbps Packet throughput ability (Full-Duplex): 14.88Mpps @64bytes
Transfer Rate	14,880pps for Ethernet port 148,800pps for Fast Ethernet port 1,488,000pps for Gigabit Fiber Ethernet port
Memory Buffer	136Kbits
MAC Address	8K MAC address table
Jumbo Frame	9Kbytes
Connector	10/100/1000T: 5 x RJ-45
Network Cable	10Base-T: 2-pair UTP/STP Cat. 3, 4, 5 cable EIA/TIA-568 100-ohm (100m) 100Base-TX: 2-pair UTP/STP Cat. 5 cable EIA/TIA-568 100-ohm (100m)
Protocol	CSMA/CD
LED	Per unit: Power 1 (Green), Power 2 (Green), Fault(Red) Per port: Link/Activity (Green), Speed (1000Mbps Green)
Power Supply	DC 12~48V Redundant power with polarity reverse protect function and removable terminal block
Power Consumption	4.6 Watt / 7.79 Watt
Operating Humidity	5%~95% (Non-condensing)
Operating Temperature	Standard -10°C~60°C Wide Operating Temperature -40°C~75°C
Storage Temperature	-40°C~85°C
Case Dimension	Metal case. IP-30, 30mm (W) x 95mm (D) x 140mm (H)
Installation	DIN Rail and Wall Mount Design
EMI	FCC Class A, CE EN61000-4-2 (ESD), CE EN61000-4-3 (RS), CE EN-61000-4-4 (EFT), CE EN61000-4-5 (Surge), CE EN61000-4-6 (CS), CE EN61000-4-8, CE EN61000-4-11, CE EN61000-4-12, CE EN61000-6-2, CE EN61000-6-4
Safety	UL, cUL, CE/EN60950-1
Stability Testing	IEC60068-2-32 (Free fall), IEC60068-2-27 (Shock), IEC60068-2-6 (Vibration)

Part Number	Description
261670100	5x10/100/1000T
261670200E	5x10/100/1000TX -40°C~+75°C
261870200	8x10/100/1000TX
261870200E	8x10/100/1000TX -40°C~+75°C

DragonLine Switch Unmanaged

4x10/100/1000TX +1xSFP



IEEE Standard	IEEE 802.3 10Base-T Ethernet IEEE 802.3u 100Base-TX and 100Base-FX Fast Ethernet IEEE 802.3ab 1000Base-T IEEE802.3x Flow Control and Back Pressure
Switch Architecture	Back-plane (Switching Fabric): 10Gbps Packet throughput ability (Full-Duplex): 14.88Mpps @64bytes
Transfer Rate	14,880pps for Ethernet port 148,800pps for Fast Ethernet port 1,488,000pps for Gigabit Fiber Ethernet port
Memory Buffer	136Kbits
MAC Address	8K MAC address table
Jumbo Frame	9Kbytes
Connector	10/100/1000T: 4 x RJ-45 Mini-GBIC: 1 x SFP socket
Network Cable	10Base-T: 2-pair UTP/STP Cat. 3, 4, 5 cable / EIA/TIA-568 100-ohm (100m) 100Base-TX: 2-pair UTP/STP Cat. 5 cable / EIA/TIA-568 100-ohm (100m)
Optical Cable	Multimode: 50/125µm~62.5/125µm Singlemode: 9/125µm Available distance: 2km (Multimode) / 30km (Singlemode) Wavelength: 1310nm (Multimode/Singlemode)
Protocol	CSMA/CD
LED	Per unit: Power 1 (Green), Power 2 (Green), Fault(Red) Per port: Link/Activity (Green), Speed (1000Mbps Green) SFP: Link/Activity (Green)
Power Supply	DC 12~48V Redundant power with polarity reverse protect function and removable terminal block
Power Consumption	5.50 Watt
Operating Humidity	5%~95% (Non-condensing)
Operating Temperature	Standard -10°C~60°C Wide Operating Temperature -40°C~75°C
Storage Temperature	-40°C~85°C
Case Dimension	Metal case. IP-30, 30mm (W) x 95mm (D) x 140mm (H)
Installation	DIN Rail and Wall Mount Design
EMI	FCC Class A, CE EN61000-4-2 (ESD), CE EN61000-4-3 (RS), CE EN-61000-4-4 (EFT), CE EN61000-4-5 (Surge), CE EN61000-4-6 (CS), CE EN61000-4-8, CE EN61000-4-11, CE EN61000-4-12, CE EN61000-6-2, CE EN61000-6-4
Safety	UL, cUL, CE/EN60950-1
Stability Testing	IEC60068-2-32 (Free fall), IEC60068-2-27 (Shock), IEC60068-2-6 (Vibration)

Part Number	Description
261470200	4x10/100/1000T + 1xSFP
261470200E	4x10/100/1000T + 1xSFP -40°C~75°C

DragonLine Switch Unmanaged

16x10/100TX + 2xCOMBO:2x10/100/1000T + 2x100/1000SFP



IEEE Standard	IEEE 802.3 10Base-T Ethernet IEEE 802.3u 100Base-TX IEEE802.3ab 1000Base-T IEEE802.3z Gigabit fiber IEEE802.3x Flow Control and Back Pressure
Switch Architecture	Back-plane (Switching Fabric): 7.2Gbps Packet throughput ability(Full-Duplex): 10.7Mpps @64bytes
Transfer Rate	14,880pps for Ethernet port 148,800pps for Fast Ethernet port 1,488,000pps for Gigabit Fiber Ethernet port
Packet Buffer	1Mbits
Mac Address	8K MAC address table
Connector	10/100TX: 16 x RJ-45 10/100/1000T/ Mini-GBIC Combo: 2 x RJ-45 + 2 x 100/1000 SFP sockets
Network Cable	10Base-T: 2-pair UTP/STP Cat. 3, 4, 5 cable EIA/TIA-568 100-ohm (100m) 100Base-TX: 2-pair UTP/STP Cat. 5/ 5E cable EIA/TIA-568 100-ohm (100m)
Optical Cable	Multimode: 50/125µm~62.5/125µm Singlemode: 9/125µm
Protocol	CSMA/CD
LED	Per unit: Power 1 (Green), Power 2 (Green), Fault (Red) 16 10/100TX : Link/Activity (Green), Full duplex/Collision (Yellow) Giga Copper: Link/Activity (Green), speed (1000M Green) SFP: Link/Activity (Green)
Power Supply	DC 12~48V Redundant power with polarity reverse protect function and removable terminal block
Power Consumption	9 Watt (Open Issue)
Operating Humidity	5% to 95% (Non-condensing)
Operating Temperature	-10°C ~ 60°C
Storage Temperature	-40°C ~ 85°C
Case Dimension	Metal case. IP-30, 72mm (W) x 105mm (D) x 152mm (H)
Installation	DIN Rail and Wall Mount Design
EMI	FCC Class A, CE EN61000-4-2 (ESD), CE EN61000-4-3 (RS), CE EN-61000-4-4 (EFT), CE EN61000-4-5 (Surge), CE EN61000-4-6 (CS), CE EN61000-4-8, CE EN61000-4-11, CE EN61000-4-12, CE EN61000-6-2, CE EN61000-6-4
Safety	UL, cUL, CE/EN60950-1
Stability Testing	IEC60068-2-32 (Free fall), IEC60068-2-27 (Shock), IEC60068-2-6 (Vibration)

Part Number	Description
26950300	16x10/100TX + 2x10/100/1000T

DragonLine Switch Managed

6x10/100TX +2x100FX and 8x10/100TX + 2x100FX



IEEE Standard	IEEE 802.3 10Base-T Ethernet IEEE 802.3u 100Base-TX and 100Base-FX Fast Ethernet IEEE802.3x Flow Control and Back Pressure IEEE802.1d Spanning Tree/ IEEE802.1w Rapid Spanning Tree IEEE802.1p Class of Service IEEE802.1Q VLAN Tag
Switch Architecture	Back-plane (Switching Fabric): 1.6Gbps Packet throughput ability (Full-Duplex): 1.19Mpps @64bytes
Transfer Rate	14,880pps for Ethernet port 148,800pps for Fast Ethernet port
Memory Buffer	1Mbits
MAC Address	2K MAC address table
Flash ROM	512Kbytes
DRAM	8Mbytes
Connector	10/100TX: RJ-45 with auto MDI/MDI-X function 100M fiber: 2 x SC type connector for Singlemode or Multimode type fiber cable
Network Cable	10Base-T: 2-pair UTP/STP Cat. 3, 4, 5 cable EIA/TIA-568 100-ohm (100m) 100Base-TX: 2-pair UTP/STP Cat. 5 cable EIA/TIA-568 100-ohm (100m)
Optical Cable	SC (Multimode): 50/125μm~62.5/125μm SC (Singlemode): 9/125μm~10/125μm Available distance: 2km (Multimode) / 30km (Singlemode) Wavelength: 1310nm (Multimode/Singlemode)
Protocol	CSMA/CD
LED	Per port: Link/Activity (Green), Full duplex/Collision (Yellow) Per unit: Power (Green), Power 1 (Green), Power 2 (Green), Fault (Yellow), Master (Green)
Power Supply	DC 12 ~48V Redundant power with polarity reverse protect function and connective removable terminal block for master and slave power
Power Consumption	6 Watt / 7,15 Watt
Operating Humidity	5%~95% (Non-condensing)
Operating Temperature	Standard 0°C ~ 60°C Wide Operating Temperature -40°C~+75°C
Storage Temperature	-40°C~85°C
Case Dimension	IP-30 Case protection, 54 mm (W) x 105mm (D) x 135 mm (H)
Installation	Provide DIN rail kit and wall mount ear for wall mount or DIN-type cabinet install
EMI	FCC Class A, CE EN6100-4-2, CE EN6100-4-3, CE EN-6100-4-4, CE EN6100-4-5, CE EN6100-4-6
Safety	UL, cUL, CE/EN60950
Stability Testing	IEC60068-2-32 (Free fall), IEC60068-2-27 (Shock), IEC60068-2-6 (Vibration)

Management	SNMP v1 v2c, Web interface management
SNMP MIB	RFC 1213 MIBII, RFC 1493 Bridge MIB, RMON RFC 1757, RFC 2674 VLAN MIB, RFC 1643 Ethernet like MIB, RFC1215 Trap MIB, IGMP MIB Private MIB for switch information, ring, port alarm, TFTP firmware upgrade, reset, port mirror, IP security
VLAN	Support Port based VLAN and IEEE802.1Q Tag VLAN Both of port based and Tag based VLAN group up to 64 VLANs
Spanning Tree	Support IEEE802.1d Spanning Tree and IEEE802.1w Rapid Spanning Tree
Ring	Support Ring, Dual Homing, and Couple Ring Provide redundant backup feature and the recovery time below 300ms
Quality of Service	The quality of service determined by port, Tag and IPv4 Type of service
Class of Service	Support IEEE802.1p class of service, per port provides 4 priority queues
Port Mirror	Support TX packet only or both of TX and RX packet
IGMP	Support IGMP v1 and Query mode. Up to 256 groups
IP Security	Support 10 IP addresses that have permission to access the switch management
Bandwidth Control	Support ingress packet filter and egress packet limit The egress rate control supports all of packet type and the limit rates are 128Kbps, 256Kbps, 512Kbps, 1Mbps, 2Mbps, 4Mbps, and 8Mbps Ingress filter packet type combination rules are Broadcast/Multicast/Unknown Unicast packet, Broadcast/Multicast packet, Broadcast packet only and all of packet. The packet filter rate can be set follow as:1Mbps, 2Mbps, 4Mbps, 8Mbps, 16Mbps, 32Mbps, 64Mbps
Flow Control	Support Flow Control for Full-duplex and Back Pressure for Half-duplex
System Log	Support System log record and remote system log server
SMTP	Support SMTP Server and 4 e-mail accounts for receiving event alert
Relay Alarm	Provides one relay output for port breakdown, power fail and provide DIP switch to mask link down port Alarm Relay current carry ability: 1A @ DC24V
SNMP Trap	Up to 3 Trap stations Cold start, Port link up, Port link down, Authentication Failure, Private Trap for power status, Port Alarm configuration, Fault alarm, Ring topology change
DHCP	Provide DHCP client function to obtain IP address from DHCP server
SNTP	Support SNTP to synchronize system clock in Internet
Firmware Update	Support TFTP firmware update, TFTP backup and restore
Configuration upload and download	Support text format configuration file for system quick installation

Part Number	Description
26670302	6x10/100TX+2xFX /MM
26670302E	6x10/100TX+2xFX /MM -40°C~+75°C
26670352	6x10/100TX+2xFX /SM
26670352E	6x10/100TX+2xFX /SM 40°C~+75°C
26870302	8x10/100TX + 2x100FX /MM
26870302E	8x10/100TX + 2x100FX MM -40°C~75°C
26870352	8x10/100TX + 2x100FX /SM
26870352E	8x10/100TX + 2x100FX /SM -40°C~75°C

DragonLine Switch Managed

8x10/100TX + 2x1000SX (LX)



IEEE Standard	IEEE 802.3 10Base-T Ethernet / IEEE 802.3u 100Base-TX / IEEE802.3z Gigabit fiber IEEE802.3x Flow Control and Back Pressure / , IEEE802.3ad Port trunk with LACP IEEE802.1d Spanning Tree / IEEE802.1w Rapid Spanning Tree IEEE802.1p Class of Service / IEEE802.1Q VLAN Tag IEEE 802.1x User Authentication (Radius) / IEEE802.1ab LLDP**
Switch Architecture	Back-plane (Switching Fabric): 5.6Gbps Packet throughput ability(Full-Duplex): 8.3Mpps @64bytes
Transfer Rate	14,880pps for Ethernet port 148,800pps for Fast Ethernet port 1,488,000pps for Gigabit Fiber Ethernet port
Packet Buffer	1Mbits
Mac Address	8K MAC address table
Flash ROM	4Mbytes
DRAM	32Mbytes
Connector	10/100TX: 8 x RJ-45 with auto MDI/MDI-X function 100M fiber: 2 x SC type connector for singlemode or multimode type fiber cable RS-232 connector: RJ-45 type
Network Cable	10Base-T: 2-pair UTP/STP Cat. 3, 4, 5 cable / EIA/TIA-568 100-ohm (100m) 100Base-TX: 2-pair UTP/STP Cat. 5/ 5E cable / EIA/TIA-568 100-ohm (100m)
Optical Cable	Multimode: 50/125μm~62.5/125μm Singlemode: 9/125μm Available distance: 550m (Multimode) / 10km (Singlemode) Wavelength: 1310nm (Multimode/Singlemode)
Protocol	CSMA/CD
LED	Per unit: Power (Green), Power 1 (Green), Power 2 (Green), Fault (Orange), Master (Green) 8 10/100: Link/Activity (Green), Full duplex/Collision (Orange) Giga port: Link/Activity
Power Supply	DC 24 ~48V Redundant power with polarity reverse protect function and removable terminal block. Input Power Isolation design for Telcom application, Pass Hi-Pot test~1.5KV
Power Consumption	7.15Watt
Operating Humidity	5% to 95% (Non-condensing)
Operating Temperature	Standard 0°C to 60°C Wide Operating Temperature (-40°C~75°C) *
Storage Temperature	-40°C to 85°C
Case Dimension	IP-30, 72mm (W) x 105mm (D) x 152mm (H)
Installation	DIN rail and wall mount ear
EMI	FCC Class A, CE EN61000-4-2, CE EN61000-4-3, CE EN-61000-4-4, CE EN61000-4-5, CE EN61000-4-6, CE EN61000-4-8, CE EN61000-4-11, CE EN61000-4-12
Safety	UL, cUL, CE/EN60950-1
Stability Testing	IEC60068-2-32 (Free fall), IEC60068-2-27 (Shock), IEC60068-2-6 (Vibration)

Management	SNMP v1 v2c, v3/ Web/Telnet/CLI/Menu Driven** Management
SNMP MIB	RFC 1215 Trap, RFC1213 MIBII, RFC 1157 SNMP MIB, RFC 1493 Bridge MIB, RFC 2674 VLAN MIB, RFC 1643 , RFC 1757, RSTP MIB, Private MIB
VLAN	Port Based VLAN IEEE 802.1Q Tag VLAN (256 entries)/ VLAN ID (Up to 4K, VLAN ID can be assigned from 1 to 4096.) GVRP (256 Groups) Double Tag VLAN (Q in Q)* Private VLAN**
Port Trunk with LACP	LACP Port Trunk: 4 Trunk groups/Maximum 4 trunk members
LLDP**	Support LLDP to allow switch to advise its identification and capability on the LAN
Spanning Tree	Support IEEE802.1d Spanning Tree and IEEE802.1w Rapid Spanning Tree
Ring	Support Ring, Dual Homing, and Couple Ring Provide redundant backup feature and the recovery time below 300ms
Quality of Service	The quality of service determined by port, Tag and IPv4 Type of service, IPv4/IPv6 Different Service
Class of Service	Support IEEE802.1p class of service, per port provides 4 priority queues
Port Security	Support 100 entries of MAC address for static MAC and another 100 for MAC filter
Port Mirror	Support 3 mirroring types: "RX, TX and Both packet".
IGMP	Support IGMP snooping v1,v2 256 multicast groups and IGMP query
IP Security	Support 10 IP addresses that have permission to access the switch management and to prevent unauthorized intruder.
Login Security	Support IEEE802.1X Authentication/RADIUS
Bandwidth Control	Support ingress packet filter and egress packet limit The egress rate control supports all of packet type and the limit rates are 100K~250Mbps Ingress filter packet type combination rules are Broadcast/Multicast/Unknown Unicast packet, Broadcast/Multicast packet, Broadcast packet only and all of packet. The packet filter rate can be set from 100k to 250Mbps
Flow Control	Support Flow Control for Full-duplex and Back Pressure for Half-duplex
System Log	Support System log record and remote system log server
SMTP	Support SMTP Server and 6 e-mail accounts for receiving event alert
Relay Alarm	Provides one relay output for port breakdown, power fail Alarm Relay current carry ability: 1A @ DC24V
SNMP Trap	Up to 3 Trap stations Cold start, Port link up, Port link down, Authentication Failure, Private Trap for power status, Port Alarm configuration, Fault alarm, Ring topology change
DHCP	Provide DHCP Client/ DHCP Server/ IP Relay functions
DNS	Provide DNS client feature and support Primary and Secondary DNS server.
SNTP	Support SNTP to synchronize system clock in Internet
Firmware Update	Support TFTP firmware update, TFTP backup and restore.
Configuration upload and download	Support binary configuration file for system quick installation

* Future release

** Optional

Part Number	Description
261870302	8x10/100TX + 2x1000SX /SC/MM/550m
261870352	8x10/100TX + 2x1000SX /SC/SM/10km
261870302E	8x10/100TX + 2x1000SX /SC/MM/550m -40°C~75°C
261870352E	8x10/100TX + 2x1000SX /SC/SM/10km -40°C~75°C

DragonLine Switch Managed

8x10/100TX + COMBO: 3x10/100/1000T + 3x100/1000 SFP



IEEE Standard	IEEE 802.3 10Base-T Ethernet / IEEE 802.3u 100Base-TX / IEEE802.1ab LLDP IEEE802.3ab 1000Base-T / IEEE802.3z Gigabit fiber / IEEE802.1p Class of Service IEEE802.3x Flow Control and Back Pressure / IEEE802.3ad Port trunk with LACP IEEE802.1d Spanning Tree/ IEEE802.1w Rapid Spanning Tree / IEEE802.1Q VLAN Tag IEEE 802.1x User Authentication (Radius)
Switch Architecture	Back-plane (Switching Fabric): 7.4Gbps Packet throughput ability(Full-Duplex): 11Mpps @64bytes
Transfer Rate	14,880pps for Ethernet port 148,800pps for Fast Ethernet port 1,488,000pps for Gigabit Fiber Ethernet port
Packet Buffer	1Mbits
Mac Address	8K MAC address table
Connector	10/100TX: 7 x RJ-45 10/100/1000T/ Mini-GBIC Combo: 3 x RJ-45 + 3 x 100/1000 SFP sockets RS-232 connector: RJ-45 type
DI/DO	2 Digital Input (DI) : Level 0 : -30~2V Level 1 : 10~30V Max. input current:8mA 2 Digital Output(DO): Open collector to 40 VDC, 200mA
Network Cable	10Base-T: 2-pair UTP/STP Cat. 3, 4, 5 cable / EIA/TIA-568 100-ohm (100m) 100Base-TX: 2-pair UTP/STP Cat. 5/5E cable / EIA/TIA-568 100-ohm (100m) 1000Base-TX: 2-pair UTP/STP Cat. 5e or 6 cable / EIA/TIA-568 100-ohm (100m)
Optical Fiber	Multimode: 50/125µm~62.5/125µm Singlemode: 9/125µm Available distance: 2km (Multimode) / 30km (Singlemode) Wavelength: 1310nm (Multimode/Singlemode)
Protocol	CSMA/CD
LED	Per unit: Power (Green), Power 1 (Green), Power 2 (Green), Fault (Red), Master (Green) 10/100TX : Link/Activity (Green), Full duplex/Collision (Yellow) Giga Copper: Link/Activity (Green), Speed (1000Mbps Green) SFP: Link/Activity (Green)
Power Supply	12~48 VDC Redundant power with polarity reverse protect function and removable terminal block
Power Consumption	10.2 Watt (Open issue)
Operating Humidity	5% to 95% (Non-condensing)
Operating Temperature	Standard -10°C~60°C / Wide Operating Temperature -40°C~75°C
Storage Temperature	-40°C to 85°C
Case Dimension	Metal case. IP-30, 72mm (W) x 105mm (D) x 152mm (H)
Installation	DIN Rail and Wall Mount Design
EMI	FCC Class A, CE EN61000-4-2 (ESD), CE EN61000-4-3 (RS), CE EN-61000-4-4 (EFT), CE EN61000-4-5 (Surge), CE EN61000-4-6 (CS), CE EN61000-4-8, CE EN61000-6-2, CE EN61000-6-4
Safety	UL, cUL, CE/EN60950-1
Stability Testing	IEC60068-2-32 (Free fall), IEC60068-2-27 (Shock), IEC60068-2-6 (Vibration)

Management	SNMP v1 v2c, v3/ Web/Telnet/CLI/NS-View Management
SNMP MIB	RFC 1215 Trap, RFC1213 MIBII, RFC 1157 SNMP MIB, RFC 1493 Bridge MIB, RFC 2674 VLAN MIB, RFC 1643 , RFC 1757, RSTP MIB, Private MIB
VLAN	Port Based VLAN IEEE 802.1Q Tag VLAN (256 entries)/ VLAN ID (Up to 4K, VLAN ID can be assigned from 1 to 4096.) GVRP (256 Groups)
Port Trunk with LACP	LACP Port Trunk: 4 Trunk groups/Maximum 4 trunk members
LLDP	Support LLDP to allow switch to advise its identification and capability on the LAN
Spanning Tree	Support IEEE802.1w Rapid Spanning Tree
Ring	Support Ring, Dual Homing, Couple Ring and Dual Ring Topology Provide redundant backup feature and the recovery time below 20ms.
Quality of Service	The quality of service determined by port, Tag and IPv4 Type of service, IPv4/IPv6 Different Service,
Class of Service	Support IEEE802.1p class of service, per port provides 4 priority queues
Port Security	Support 100 entries of MAC address for static MAC and another 100 for MAC filter
Port Mirror	Support 3 mirroring types: "RX, TX and Both packet".
IGMP	Support IGMP snooping v1,v2 256 multicast groups and IGMP query Support multicast filter
IP Security	Support 10 IP addresses that have permission to access the switch management and to prevent unauthorized intruder.
Login Security	Support IEEE802.1X Authentication/RADIUS
Bandwidth Control	Support ingress packet filter and egress packet limit The egress rate control supports all of packet type and the limit rates are 100K~250Mbps Ingress filter packet type combination rules are Broadcast/Multicast/Unknown Unicast packet, Broadcast/Multicast packet, Broadcast packet only and all of packet. The packet filter rate can be set from 100k to 250Mbps,
Flow Control	Support Flow Control for Full-duplex and Back Pressure for Half-duplex
System Log	Support System log record and remote system log server
SMTP	Support SMTP Server and 6 e-mail accounts for receiving event alert
Relay Alarm	Provides one relay output for port breakdown, power fail Alarm Relay current carry ability: 1A @ DC24V
DIDO	DO: When disconnection of the specific port was detected, DO will activate the signal LED to alarm. DI: Integrate critical sensors: 2 groups of digital inputs. DI can integrate the sensors into the auto alarm system and transfer the alarm information to IP network with email and SNMP.
SNMP Trap	Up to 3 Trap stations Cold start, Port link up, Port link down, Authentication Failure, Private Trap for power status, Port Alarm configuration, Fault alarm, Ring topology change
DHCP	Provide DHCP Client, DHCP Server and IP Relay
DNS	Provide DNS client feature and support Primary and Secondary DNS server
SNTP	Support SNTP to synchronize system clock in Internet
Firmware Update, configuration backup and restore	Support TFTP firmware update, System configure backup and restore.
ifAlias	Each port allows importing 128bit of alphabetic string of word on SNMP and CLI interface.

** Optional

Part Number	Description
261770300	Industrial Ethernet Switch (Managed / Ring)
261770300E	Industrial Ethernet Switch (Managed / Ring) -40°C~75°C

DragonLine Switch Managed

16x10/100TX + COMBO: 2x10/100/1000T + 2x100/1000 SFP



IEEE Standard	IEEE 802.3 10Base-T Ethernet / IEEE 802.3u 100Base-TX / IEEE802.3ab 1000Base-T IEEE802.3z Gigabit fiber / IEEE802.3x Flow Control and Back Pressure IEEE802.3ad Port trunk with LACP / IEEE 802.1x User Authentication (Radius) IEEE802.1d Spanning Tree/ IEEE802.1w Rapid Spanning Tree / IEEE802.1Q VLAN Tag IEEE802.1p Class of Service / IEEE802.1ab LLDP
Switch Architecture	Back-plane (Switching Fabric): 7.2Gbps Packet throughput ability(Full-Duplex): 10.7Mpps @64bytes
Transfer Rate	14,880pps for Ethernet port 148,800pps for Fast Ethernet port 1,488,000pps for Gigabit Fiber Ethernet port
Packet Buffer	1Mbits
Mac Address	8K MAC address table
Flash ROM	4Mbytes
DRAM	32Mbytes
Connector	10/100TX: 16 x RJ-45 10/100/1000T/ Mini-GBIC Combo: 2 x RJ-45 + 2 x 100/1000 SFP sockets RS-232 connector: RJ-45 type
Network Cable	10Base-T: 2-pair UTP/STP Cat. 3, 4, 5 cable / EIA/TIA-568 100-ohm (100m) 100Base-TX: 2-pair UTP/STP Cat. 5/5E cable / EIA/TIA-568 100-ohm (100m)
Optical Cable	Multimode: 50/125µm~62.5/125µm Singlemode: 9/125µm Available distance: 2km (Multimode) / 30km (Singlemode) Wavelength: 1310nm (Multimode/Singlemode)
Protocol	CSMA/CD
LED	Per unit: Power (Green), Power 1 (Green), Power 2 (Green), Fault (Red), Master (Green) 16 10/100TX : Link/Activity (Green), Full duplex/Collision (Yellow) Giga Copper: Link/Activity (Green), Speed (1000Mbps Green) SFP: Link/Activity (Green)
Power Supply	DC 12~48V Redundant power with polarity reverse protect function and removable terminal block
Power Consumption	11.5Watt max.
Operating Humidity	5% to 95% (Non-condensing)
Operating Temperature	Standard: -10°C~60°C Wide Operating Temperature -40°C~75°C*
Storage Temperature	-40°C to 85°C
Case Dimension	Metal case. IP-30, 72mm (W) x 105mm (D) x 152mm (H)
Installation	DIN Rail and Wall Mount Design
EMI	FCC Class A, CE EN61000-4-2 (ESD), CE EN61000-4-3 (RS), CE EN-61000-4-4 (EFT), CE EN61000-4-5 (Surge), CE EN61000-4-6 (CS), CE EN61000-4-8, CE EN61000-4-11, CE EN61000-4-12, CE EN61000-6-2, CE EN61000-6-4
Safety	UL, cUL, CE/EN60950-1
Stability Testing	IEC60068-2-32 (Free fall), IEC60068-2-27 (Shock), IEC60068-2-6 (Vibration)

Management	SNMP v1 v2c, v3/ Web/Telnet/CLI/NS-View Management
SNMP MIB	RFC 1215 Trap, RFC1213 MIBII, RFC 1157 SNMP MIB, RFC 1493 Bridge MIB, RFC 2674 VLAN MIB, RFC 1643 , RFC 1757, RSTP MIB, Private MIB
VLAN	Port Based VLAN IEEE 802.1Q Tag VLAN (256 entries)/ VLAN ID (Up to 4K, VLAN ID can be assigned from 1 to 4096.)GVRP (256 Groups)
Port Trunk with LACP	LACP Port Trunk: 4 Trunk groups/Maximum 4 trunk members
LLDP	Support LLDP to allow switch to advise its identification and capability on the LAN
Spanning Tree	Support IEEE802.1w Rapid Spanning Tree
Ring	Support Ring, Dual Homing, Couple Ring and Central Ring Topology. Provide redundant backup feature and the recovery time below 20ms. Central Ring can handle up to 4 rings by configuring a single switch only as the Ring Master switch.
Quality of Service	The quality of service determined by port, Tag and IPv4 Type of service, IPv4/IPv6 Different Service
Class of Service	Support IEEE802.1p class of service, per port provides 4 priority queues
Port Security	Support 100 entries of MAC address for static MAC and another 100 for MAC filter
Port Mirror	Support 3 mirroring types: "RX, TX and Both packet".
IGMP	Support IGMP snooping v1,v2 256 multicast groups and IGMP query Support multicast filter
IP Security	Support 10 IP addresses that have permission to access the switch management and to prevent unauthorized intruder.
Login Security	Support IEEE802.1X Authentication/RADIUS
Bandwidth Control	Support ingress packet filter and egress packet limit The egress rate control supports all of packet type and the limit rates are 100K~250Mbps Ingress filter packet type combination rules are Broadcast/Multicast/Unknown Unicast packet, Broadcast/Multicast packet, Broadcast packet only and all of packet. The packet filter rate can be set from 100k to 250Mbps
Flow Control	Support Flow Control for Full-duplex and Back Pressure for Half-duplex
System Log	Support System log record and remote system log server
SMTP	Support SMTP Server and 6 e-mail accounts for receiving event alert
Relay Alarm	Provides one relay output for port breakdown, power fail Alarm Relay current carry ability: 1A @ DC24V
SNMP Trap	Up to 3 Trap stations Cold start, Port link up, Port link down, Authentication Failure, Private Trap for power status, Port Alarm configuration, Fault alarm, Ring topology change
DHCP	Provide DHCP Client/ DHCP Server functions
DNS	Provide DNS client feature and support Primary and Secondary DNS server
SNTP	Support SNTP to synchronize system clock in Internet
Firmware Update	Support TFTP firmware update, TFTP backup and restore.
Configuration upload and download	Support binary configuration file for system quick installation
ifAlias	Each port allows importing 128bit of alphabetic string of word on SNMP and CLI interface.

* Future release

** Optional

Part Number	Description
26970300	16x10/100TX + 2x10/100/1000T/ Mini-GBIC Combo
26970300E	16x10/100TX + 2x10/100/1000T/ Mini-GBIC Combo -40°C~75°C

DragonLine Switch Managed

6x10/100TX + COMBO: 2x10/100/1000T + 2x1000 SFP



IEEE Standard	IEEE 802.3 10Base-T Ethernet / IEEE 802.3u 100Base-TX / IEEE802.3ab 1000Base-T IEEE802.3z Gigabit fiber / IEEE802.3x Flow Control and Back Pressure IEEE802.3ad Port trunk with LACP / IEEE 802.1x User Authentication (Radius IEEE802.1d Spanning Tree/ IEEE802.1w Rapid Spanning Tree / IEEE802.1Q VLAN Tag IEEE802.1p Class of Service / IEEE802.1ab LLDP
RFC Standard	RFC2030 SNMP, RFC 2821 SMTP, RFC 1215 Trap, RFC2233 MIBII, RFC 1157 SNMP MIB, RFC 1493 Bridge MIB, RFC 2674 VLAN MIB, RFC 2665 Ethernet like MIB, RFC 2819 RMON MIB, Private MIB
Switch Architecture	Back-plane (Switching Fabric): 16Gbps Packet throughput ability (Full-Duplex): 23.8Mpps @64bytes
Transfer Rate	14,880pps for Ethernet port 148,800pps for Fast Ethernet port 1,488,000pps for Gigabit Fiber Ethernet port
Packet Buffer	1Mbits
Mac Address	8K MAC address table
Connector	10/100/1000TX: 6 ports RJ-45 with Auto MDI/MDI-X function Gigabit fiber: 2 x Mini-GBIC socket. RS-232 connector: RJ-45 type
Network Cable	10Base-T: 2-pair UTP/STP Cat. 3, 4, 5 cable / EIA/TIA-568 100-ohm (100m) 100Base-TX: 2-pair UTP/STP Cat. 5 / 5E cable / EIA/TIA-568 100-ohm (100m)
Optical Cable	Multimode: 50/125µm~62.5/125µm Singlemode: 9/125µm~10/125µm Available distance: 2km (Multimode) / 30km (Singlemode) Wavelength: 1310nm (Multimode/ Singlemode)
Protocol	CSMA/CD
LED	Per unit: Power (Green), Power 1 (Green), Power 2 (Green), Fault (Yellow), Master (Green) Per port: Link/Activity (Green), speed (1000 Green) Mini GBIC: Link/Activity (Green)
Power Supply	DC 24 ~48V Redundant power with polarity reverse protect function and connective removable terminal block for master and slave power Input Power Isolation design for Telecom application, Pass Hi-Pot test~1.5KV
Power Consumption	Watt
Operating Humidity	5% to 95% (Non-condensing)
Operating Temperature	Standard 0°C to 60°C / Wide Operating Temperature -40°C~75°C
Storage Temperature	-40°C to 85°C
Case Dimension	IP-31, 72mm (W) x 105mm (D) x 152mm (H)
Fan Number	0
Installation	Provide DIN rail kit and wall mount ear for wall mount or DIN-type cabinet install
EMI	FCC Class A, CE EN6100-4-2, CE EN6100-4-3, CE EN-6100-4-4, CE EN6100-4-5, CE EN6100-4-6, EN6100-4-8, EN6100-4-11
Safety	UL, cUL, CE/EN60950-1
Stability Testing	IEC60068-2-32 (Free fall), IEC60068-2-27 (Shock), IEC60068-2-6 (Vibration)

Management	SNMP v1 v2c, v3/ Web/Telnet/CLI/Menu Driven Management
VLAN	Port Based VLAN IEEE 802.1Q Tag VLAN (256 entries)/ VLAN ID (Up to 4K, VLAN ID can be assigned from 1 to 4096.) GVRP (256 Groups) Double Tag VLAN Private VLAN
Port Trunk with LACP	LACP Port Trunk: 4 Trunk groups/Maximum 4 trunk members
LLDP	Support LLDP to allow switch to advise its identification and capability on the LAN
Spanning Tree	Support IEEE802.1d Spanning Tree and IEEE802.1w Rapid Spanning Tree
Ring	Support Ring, Dual Homing, and Couple Ring Provide redundant backup feature and the recovery time below 300ms
Quality of Service	The quality of service determined by port, Tag and IPv4 Type of service, IPv4/ IPv6 Different Service
Class of Service	Support IEEE802.1p class of service, per port provides 4 priority queues
Port Security	Support 100 entries of MAC address for static MAC and another 100 for MAC filter
Port Mirror	Support 3 mirroring types: "RX, TX and Both packet".
IGMP	Support IGMP snooping v1,v2 256 multicast groups and IGMP query
IP Security	Support 10 IP addresses that have permission to access the switch management and to prevent unauthorized intruder.
Bandwidth Control	Support ingress packet filter and egress packet limit The egress rate control supports all of packet type and the limit rates are 100K~250Mbps Ingress filter packet type combination rules are Broadcast/Multicast/Unknown Unicast packet, Broadcast/Multicast packet, Broadcast packet only and all of packet. The packet filter rate can be set from 100k to 250Mbps
Flow Control	Support Flow Control for Full-duplex and Back Pressure for Half-duplex
System Log	Support System log record and remote system log server
SMTP	Support SMTP Server and 6 e-mail accounts for receiving event alert
Relay Alarm	Provides one relay output for port breakdown, power fail and alarm Alarm Relay current carry ability: 1A @ DC24V
SNMP Trap	Up to 3 Trap stations Cold start, Port link up, Port link down, Authentication Failure, Private Trap for power status, Port Alarm configuration, Fault alarm, Ring topology change
DHCP	Provide DHCP Client/ DHCP Server/ IP Relay functions
DNS	Provide DNS client feature and support Primary and Secondary DNS server.
SNTP	Support SNTP to synchronize system clock in Internet
Firmware Update	Support TFTP firmware update, TFTP backup and restore.
Configuration upload and download	Support text format configuration file for system quick installation

Part Number	Description
261670300	6x10/100/1000TX + 2x10/100/1000/Mini-GBIC

DragonLine POE Media Converter

1x10/100TX to 1x100FX



Standard	IEEE802.3 10BASE-T / IEEE802.3u 100BASE-TX/100BASE-FX IEEE802.3x Flow Control and Back pressure / IEEE802.3af Power over Ethernet
Switch Architecture	Store and Forward
Link Lose Forward	TX →Fiber: If TX port link down, the media converter will force Fiber port to link down Fiber →TX: If Fiber port link down, the media converter will force TX port to link down
Transfer Rate	14,880pps for Ethernet port 148,800pps for Fast Ethernet port
Connector	10/100TX: 1 x RJ-45 with auto MDI/MDI-X function; Support PoE injector function 100M fiber: 1 x SC type connector for Singlemode or Multimode type fiber cable
PoE pin assignment	RJ-45 port # 1~# 4 support IEEE 802.3af End-point, Alternative B mode. Positive (VCC+): RJ-45 pin 1, 2. Negative (VCC-): RJ-45 pin 3, 6. Data (1,2,3,6)
Network Cable	10Base-T: 2-pair UTP/STP Cat. 3, 4, 5 cable / EIA/TIA-568 100-ohm (100m) 100Base-TX: 2-pair UTP/STP Cat. 5 cable / EIA/TIA-568 100-ohm (100m)
Optical Fiber	Multimode: 50/125μm~62.5/125μm Singlemode: 9/125μm Available distance: 2km (Multimode)/30km (Singlemode) Wavelength: 1310nm (Multimode/Singlemode)
Protocol	CSMA/CD
LED	Per unit: Power 1 (Green), Power 2 (Green), Fault(Red) TX: Link/Active (Green), 100M(Yellow), Feeding Power (Green) Fiber: Link/Active (Green), Full duplex/Collision (Yellow)
Power Supply	DC 48V Redundant Power
Power Consumption	3.3Watt (without PoE); 16.4Watt (Full load with PoE)
Operating Humidity	5%~95% (Non-condensing)
Operating Temperature	Standard: -10°C~60°C
Storage Temperature	-40°C~85°C
Case Dimension	Metal case. IP-30, 30mm (W) x 95mm (D) x 140mm (H)
Installation	DIN Rail and Wall Mount Design
EMI	FCC Class A, CE EN61000-4-2 (ESD), CE EN61000-4-3 (RS), CE EN-61000-4-4 (EFT), CE EN61000-4-5 (Surge), CE EN61000-4-6 (CS), CE EN61000-4-8, CE EN61000-4-11, CE EN61000-6-2, CE EN61000-6-4
Safety	UL, cUL, CE/EN60950-1
Stability Testing	IEC60068-2-32 (Free fall), IEC60068-2-27 (Shock), IEC60068-2-6 (Vibration)

Part Number	Description
26P170201	1x10/100TX + 1x100FX SC/MM/2km
26P170251	1x10/100TX + 1x100FX SC/SM/30km

DragonLine POE Switch Unmanaged

4x10/100TX POE + 1x10/100TX



IEEE Standard	IEEE 802.3 10Base-T Ethernet / IEEE 802.3u 100Base-TX Fast Ethernet IEEE802.3x Flow Control and Back Pressure / IEEE802.3af Power over Ethernet
Switch Architecture	Back-plane (Switching Fabric): 1.0Gbps Packet throughput ability (Full-Duplex): 1.488Mpps @64bytes
Transfer Rate	14,880pps for Ethernet port 148,800pps for Fast Ethernet port
Memory Buffer	448Kbits
MAC Address	2K
Connector	10/100TX: 5 x RJ-45 with auto MDI/MDI-X function; Support 4 PoE injector function
PoE pin assignment	RJ-45 port # 1~# 4 support IEEE 802.3af End-point, Alternative A mode. Positive (VCC+): RJ-45 pin 1, 2. Negative (VCC-): RJ-45 pin 3, 6. Data (1,2,3,6)
Network Cable	10Base-T: 2-pair UTP/STP Cat. 3, 4, 5 cable / EIA/TIA-568 100-ohm (100m) 100Base-TX: 2-pair UTP/STP Cat. 5 cable / EIA/TIA-568 100-ohm (100m)
Protocol	CSMA/CD
LED	Per unit: Power 1 (Green), Power 2 (Green), Fault(Red) Per port: Link/Activity (Green), Full duplex/Collision (Yellow) PoE: Feeding Power (Green)
Overload current protection	Present (Support PIFE-401A)
Power Supply	DC 48V Redundant Power
Power Consumption	3.4Watts (without PoE); 57Watts (Full load with PoE)
Operating Humidity	5%~95% (Non-condensing)
Operating Temperature	Standard: -10°C~60°C, Wide Operating Temperature: -40°C~75°C
Storage Temperature	-40°C~85°C
Case Dimension	Metal case. IP-30, 30mm (W) x 95mm (D) x 140mm (H)
Installation	DIN Rail and Wall Mount Design
EMI	FCC Class A, CE EN61000-4-2 (ESD), CE EN61000-4-3 (RS), CE EN-61000-4-4 (EFT), CE EN61000-4-5 (Surge), CE EN61000-4-6 (CS), CE EN61000-4-8, CE EN61000-4-11, CE EN61000-6-2, CE EN61000-6-4
Safety	UL, cUL, CE/EN60950-1
Stability Testing	IEC60068-2-32 (Free fall), IEC60068-2-27 (Shock), IEC60068-2-6 (Vibration)

Part Number	Description
26P670100E	4x10/100TX w/ 4 PoE Injector + 1x10/100TX -40°C~75°C

DragonLine POE Switch Unmanaged

4x10/100TX + 1x100FX



IEEE Standard	IEEE 802.3 10Base-T Ethernet / IEEE 802.3u 100Base-TX and 100Base-FX Fast Ethernet IEEE802.3x Flow Control and Back Pressure / IEEE802.3af Power over Ethernet
Switch Architecture	Back-plane (Switching Fabric): 1.0Gbps / Packet throughput ability (Full-Duplex): 1.488Mpps @64bytes
Transfer Rate	14,880pps for Ethernet port 148,800pps for Fast Ethernet port
MAC Address	1K MAC address table
Connector	10/100TX: 4 x RJ-45 with auto MDI/MDI-X function; Support PoE injector function 100M fiber: 1 x SC type connector for Singlemode or Multimode type fiber cable
PoE pin assignment	RJ-45 port # 1~# 4 support IEEE 802.3af End-point, Alternative B mode. Positive (VCC+): RJ-45 pin 1, 2. Negative (VCC-): RJ-45 pin 3, 6. Data (1,2,3,6)
Network Cable	10Base-T: 2-pair UTP/STP Cat. 3, 4, 5 cable / EIA/TIA-568 100-ohm (100m) 100Base-TX: 2-pair UTP/STP Cat. 5 cable / EIA/TIA-568 100-ohm (100m)
Optical Fiber	Multimode: 50/125μm~62.5/125μm Singlemode: 9/125μm Available distance: 2km (Multimode) / 30km (Singlemode) Wavelength: 1310nm (Multimode/Singlemode)
Protocol	CSMA/CD
LED	Per unit: Power 1 (Green), Power 2 (Green), Fault(Red) Fiber: Link/Active(Green) TX: Link/Active(Green), Full duplex/Collision (Yellow) PoE: Feeding Power (Green)
Power Supply	DC 48V Redundant Power
Power Consumption	4.6Watt (without PoE); 58Watt (Full load with PoE)
Operating Humidity	5%~95% (Non-condensing)
Operating Temperature	-10°C ~ 60°C
Storage Temperature	-40°C ~ 85°C
Case Dimension	Metal case. IP-30, 30mm (W) x 95mm (D) x 140mm (H)
Installation	DIN Rail and Wall Mount Design
EMI	FCC Class A, CE EN61000-4-2 (ESD), CE EN61000-4-3 (RS), CE EN-61000-4-4 (EFT), CE EN61000-4-5 (Surge), CE EN61000-4-6 (CS), CE EN61000-4-8, CE EN61000-4-11, CE EN61000-6-2, CE EN61000-6-4
Safety	UL, cUL, CE/EN60950-1
Stability Testing	IEC60068-2-32 (Free fall), IEC60068-2-27 (Shock), IEC60068-2-6 (Vibration)

Part Number	Description
26P470201	4x10/100TX + 1x100FX SC/MM/2km
26P470201E	4x10/100TX + 1x100FX /SC/MM/2km -40°C~75°C
26P470251	4x10/100TX + 1x100FX /SC/SM/10km
26P470251E	4x10/100TX + 1x100FX /SC/SM/10km -40°C~75°C

DragonLine POE Switch Unmanaged

8x10/100TX + COMBO: 2x10/100/1000T + 2x1000SFP



IEEE Standard	IEEE 802.3 10Base-T Ethernet / IEEE 802.3u 100Base-TX / IEEE802.3ab 1000Base-T IEEE802.3z Gigabit fiber / IEEE802.3af Power over Ethernet IEEE802.3x Flow Control and Back Pressure
Switch Architecture	Back-plane (Switching Fabric): 5.6Gbps Packet throughput ability(Full-Duplex): 8.3Mpps @64bytes
Transfer Rate	14,880pps for Ethernet port 148,800pps for Fast Ethernet port 1,488,000pps for Gigabit Fiber Ethernet port
Mac Address	8K MAC address table
Connector	10/100TX: 8 x RJ-45 10/100/1000T/ Mini-GBIC Combo: 2 x RJ-45 + 2 x 100/1000 SFP sockets
Network Cable	10Base-T: UTP/STP Cat. 3, 4, 5/ 5E cable / EIA/TIA-568 100-ohm (100m) 100Base-TX: UTP/STP Cat. 5/ 5E cable / EIA/TIA-568 100-ohm (100m) 1000Base-TX: UTP/STP Cat. 5/ 5E cable / EIA/TIA-568 100-ohm (100m)
Optical Fiber	Multimode: 50/125um~62.5/125um 1300nm Singlemode: 9/125um 1300nm Available distance: 2km (Multimode) 30km (Singlemode)
PoE pin assignment	RJ-45 port # 1~# 8 support IEEE 802.3af End-point, Alternative A mode. Per port provides 15.4W ability / Positive (VCC+): RJ-45 pin 1,2 / Negative (VCC-): RJ-45 pin 3,6
Protocol	CSMA/CD
LED	Per unit: Power (Green), Power 1 (Green), Power 2 (Green), Fault (Red), 8 port 10/100: Link/Activity (Green), Full duplex/Collision (Yellow), Power Feeding (Green) Giga port: Link/Activity
Relay Alarm	Provides one relay output for port breakdown, power fail and alarm. Alarm Relay current carry ability: 1A @ DC24V
Power Supply	External Power Supply: DC 48V, Redundant power DC 48V and connective removable terminal block. Maximal power: 140 Watts.
Power Consumption	16.8 Watts (Max.); POE Power Budget: 123.2 Watts (Max.)
Operating Humidity	5% to 95% (Non-condensing)
Operating Temperature	-10°C to 60°C; Wide Operating Temperature: -40°C~75°C
Storage Temperature	-40°C to 85°C
Case Dimension	IP-30, 72mm (W) x 105mm (D) x 152mm (H)
Installation	Provide DIN rail kit and wall mount ear for wall mount or DIN-type cabinet install
EMI	FCC Class A, CE EN61000-4-2 (ESD), CE EN61000-4-3 (RS), CE EN-61000-4-4 (EFT), CE EN61000-4-5 (Surge), CE EN61000-4-6 (CS), CE EN61000-4-8, CE EN61000-4-11, CE EN61000-4-12, CE EN61000-6-2, CE EN61000-6-4
Safety	UL, cUL, CE/EN60950-1
Stability Testing	IEC60068-2-32 (Free fall), IEC60068-2-27 (Shock), IEC60068-2-6 (Vibration)

Part Number	Description
26P1870200	8x10/100TX + 2x10/100/1000FX
26P1870200E	8x10/100TX + 2x10/100/1000FX -40°C~75°C

DragonLine POE Switch Managed

8x10/100TX + COMBO: 2x10/100/1000T + 2x1000SFP



IEEE Standard	IEEE 802.3 10Base-T Ethernet / IEEE 802.3u 100Base-TX / IEEE802.3ab 1000Base-T IEEE802.3z Gigabit fiber / IEEE802.3x Flow Control and Back Pressure IEEE802.3ad Port trunk with LACP / IEEE802.3af Power over Ethernet IEEE802.1d Spanning Tree/ IEEE802.1w Rapid Spanning Tree / IEEE802.1ab LLDP IEEE802.1p Class of Service / IEEE 802.1x User Authentication (Radius) IEEE802.1Q VLAN Tag
Switch Architecture	Back-plane (Switching Fabric): 5.6Gbps Packet throughput ability(Full-Duplex): 8.3Mpps @64bytes
Transfer Rate	14,880pps for Ethernet port 148,800pps for Fast Ethernet port 1,488,000pps for Gigabit Fiber Ethernet port
Packet Buffer	1Mbits
Mac Address	8K MAC address table
Connector	10/100TX: 8 x ports RJ-45 with Auto MDI/MDI-X function Gigabit fiber: 2 x Mini-GBIC socket. RS-232 connector: RJ-45 type
Network Cable	10Base-T: 2-pair UTP/STP Cat. 3, 4, 5/ 5E cable / EIA/TIA-568 100-ohm (100m) 100Base-TX: 2-pair UTP/STP Cat. 5/ 5E cable / EIA/TIA-568 100-ohm (100m) 1000Base-TX: 2-pair UTP/STP Cat. 5/ 5E cable / EIA/TIA-568 100-ohm (100m)
Optical Cable	Multimode: 50/125µm~62.5/125µm Singlemode: 9/125µm~10/125µm Available distance: 2km (Multimode) / 30KM (Singlemode) Wavelength: 1310nm (Multimode/ Singlemode)
PoE pin assignment	RJ-45 port # 1~# 8 support IEEE 802.3af End-point, Alternative B mode. Per port provides 15.4W ability / Positive (VCC+): RJ-45 pin 4,5. / Negative (VCC-): RJ-45 pin 7,8.
Protocol	CSMA/CD
LED	Per unit: Power (Green), Power 1 (Green), Power 2 (Green), Fault (Yellow), Master (Green) 8 port 10/100: Link/Activity (Green), Full duplex/Collision (Yellow) Giga port: Link/Activity
Power Supply	External Power Supply: DC 48V Redundant power DC 48V Connective removable terminal block for master and slave power
Operating Humidity	5% to 95% (Non-condensing)
Operating Temperature	Standard -10°C to 60°C Wide Operating Temperature -40°C~75°C
Storage Temperature	-40°C to 70°C
Case Dimension	IP-30, 72mm (W) x 105mm (D) x 152mm (H)
Installation	Provide DIN rail kit and wall mount ear for wall mount or DIN-type cabinet install
EMI	FCC Class A, CE EN61000-4-2, CE EN61000-4-3, CE EN-61000-4-4, CE EN61000-4-5, CE EN61000-4-6, CE EN61000-4-8, CE EN61000-4-11
Safety	UL, cUL, CE/EN60950-1
Stability Testing	IEC60068-2-32 (Free fall), IEC60068-2-27 (Shock), IEC60068-2-6 (Vibration)

Management	SNMP v1 v2c, v3/ Web/Telnet/CLI/Menu Driven**
SNMP MIB	RFC 1215 Trap, RFC1213 MIBII, RFC 1157 SNMP MIB, RFC 1493 Bridge MIB, RFC 2674 VLAN MIB, RFC 1643 , RFC 1757, RSTP MIB, Private MIB
VLAN	Port Based VLAN IEEE 802.1Q Tag VLAN (256 entries)/ VLAN ID (Up to 4K, VLAN ID can be assigned from 1 to 4096.) GVRP (256 Groups) Double Tag VLAN (Q in Q)* Private VLAN**
Port Trunk with LACP	LACP Port Trunk: 4 Trunk groups/Maximum 4 trunk members
LLDP**	Support LLDP to allow switch to advise its identification and capability on the LAN
Spanning Tree	Support IEEE802.1d Spanning Tree and IEEE802.1w Rapid Spanning Tree
Ring	Support Ring, Dual Homing, and Couple Ring Provide redundant backup feature and the recovery time below 300ms
Quality of Service	The quality of service determined by port, Tag and IPv4 Type of service, IPv4/IPv6 Different Service
Class of Service	Support IEEE802.1p class of service, per port provides 4 priority queues
Port Security	Support 100 entries of MAC address for static MAC and another 100 for MAC filter
Port Mirror	Support 3 mirroring types: "RX, TX and Both packet".
IGMP	Support IGMP snooping v1,v2 256 multicast groups and IGMP query
IP Security	Support 10 IP addresses that have permission to access the switch management and to prevent unauthorized intruder.
Login Security	Support IEEE802.1X Authentication/RADIUS
Bandwidth Control	Support ingress packet filter and egress packet limit The egress rate control supports all of packet type and the limit rates are 100K~250Mbps Ingress filter packet type combination rules are Broadcast/Multicast/Unknown Unicast packet, Broadcast/Multicast packet, Broadcast packet only and all of packet. The packet filter rate can be set from 100k to 250Mbps
Flow Control	Support Flow Control for Full-duplex and Back Pressure for Half-duplex
System Log	Support System log record and remote system log server
SMTP	Support SMTP Server and 6 e-mail accounts for receiving event alert
Relay Alarm	Provides one relay output for port breakdown, power fail and alarm. Alarm Relay current carry ability: 1A @ DC24V
SNMP Trap	Up to 3 Trap stations Cold start, Port link up, Port link down, Authentication Failure, Private Trap for power status, Port Alarm configuration, Fault alarm, Ring topology change
DHCP	Provide DHCP Client/ DHCP Server/ IP Relay functions
DNS	Provide DNS client feature and support Primary and Secondary DNS server.
SNTP	Support SNTP to synchronize system clock in Internet
Firmware Update	Support TFTP firmware update, TFTP backup and restore.
Configuration upload and download	Support text format configuration file for system quick installation

* Future Release

** Optional

Part Number	Description
26P1870300	8x10/100TX + 2x10/100/1000FX

DragonLine POE 19"-Switch Managed

24x10/100TX + COMBO: 2x10/100/1000T + 2x1000SFP



Standard	IEEE802.3 10BASE-T / IEEE802.3u 100BASE-TX/100BASE-FX IEEE802.3z Gigabit SX/LX / IEEE802.3ab Gigabit 1000T IEEE802.3x Flow Control and Back pressure / IEEE802.3ad Port trunk with LACP IEEE802.1d Spanning tree protocol / IEEE802.1w Rapid spanning tree protocol IEEE802.1p Class of service / IEEE802.1Q VLAN Tagging IEEE 802.1x user authentication / IEEE802.3af Power over Ethernet
Connector	10/100TX: 24 x RJ-45 Gigabit Copper: 2 x RJ-45 2 MINI GBIC for MINI GBIC transceiver
Switch architecture	Store and forward switch architecture. Back-plane up to 8.8Gbps
MAC address	8K MAC address table with Auto learning function
Memory	3Mbits for packet buffer
Flash ROM	512Kbytes x 2
System memory	8Mbytes x 1
LED	System Power 10/100TX RJ-45 Port: Link/Active (Green: 1000Mbps/ Yellow: 10/100Mbps), Full-duplex/collision MINI GBIC/ Copper: Link/Activity, Full duplex/collision, 1000Mbps, 100Mbps
Connector	24-port RJ-45 for 10/100TX RJ-45 Pin assignment and polarity: 1/2:RX signal and -48V DC; 3/6:TX signal and +48V DC
RS-232 connector	One RS-232 DB-9 female connector for switch management and 2 RS-232 DB-9 male connectors on rear side for DC power supply and UPS management.
Remote power feeding	End-point insert type and compatible with IEEE802.3af Per port feeding power: 15.4Watt (maximum)
Power	Embedded AC power supply: AC 100~240V, 50/60Hz, 200W Extra power input: DC48V
Power consumption	20W (maximum /without PD)
Ventilation	2 DC Fans with detect function
Operating environment	0°C~40°C, 10%~95%RH
Storage environment	-40°C~70°C, 95% RH
Dimension	440mm(W) x 280mm(D) x 44mm(H)
EMI	FCC Class A, CE
Safety	UL, cUL, CE/EN60950
Management	SNMP management, Telnet management, web management, RS-232 terminal console for command line interface management
SNMP MIB	RFC 1157 SNMP, RFC 1213 MIB II, RFC 1643 Ethernet like, RFC 1493 Bridge MIB, RFC 2674 VLAN MIB, private MIB, RFC 1628 UPS MIB, RFC3621 Power Ethernet MIB
RFC standard	RFC 2030 SNTP, RFC 2821 SMTP (option), RFC 1492 TACACS+ (option), RFC 1215 Trap, RFC 1757 RMON 1

Type of Trap	Cold start, warm start, link down, link up, authorization fail, Trap station up to 3. Private trap for power supply device.
Software Upgrade	TFTP and console firmware upgradeable.
Port Trunk	Support IEEE802.3ad with LACP function. Up to 7 trunk groups and group member up to 4. The trunk port within 24-port 10/100TX and extension module.
Spanning Tree	IEEE802.1d spanning tree, IEEE802.1w rapid spanning tree.
VLAN	Port based VLAN / IEEE802.1Q Tag VLAN / IEEE802.1v Protocol VLAN (IP, IPX,...) The static VLAN groups up to 256 and dynamic VLAN groups up to 2048, the VLAN ID can be assigned from 1 to 4094.
Class of Service	Per system supports high and low queues. The priority service rule: first come first service, all High before Low, WRR for High or low weight.
Port-based Priority	Support 3 settings: "Disable, Low or High priority". When set to "Disable", the income packet will follow QOS policy; Otherwise, the packet will follow port priority setting to "High/Low" queue.
IGMP	It supports IGMP snooping for multimedia application and supports 256 groups
Port Security	It supports ingress and egress MAC address filter and static source MAC address lock.
Port Mirror	Global system supports 3 mirroring types: "RX, TX and Both packet". The maximum of port mirror entries is up to 25.
Bandwidth Control	Per port supports bandwidth control. Per level 100Kbps.
802.1x Authentication	Support IEEE802.1x User-Authentication and can report to RADIUS server. <ul style="list-style-type: none"> ➤ Reject ➤ Accept ➤ Authorize ➤ Disable
DHCP	DHCP client
Packet filter	Broadcast storm filter
System setup and control	System calibrate, AC power line frequency rejection, IEEE 802.3af resistor range adjust
Port configuration control	Port Disable / Enable. PD detect control (enable/disable), Classification detect control (enable/disable), DC disconnect detect control
Fault status detect	Null: no PD present Overload: current support over 475mA @ DC 48V and over 50 milliseconds DR fail: PD discovery resistor is not in the limited range
Mode status	System detects status, it will show I –sample, V-sample and R-detect.
Parametric information	It will show current PD parameters, it include Discover-resistor detected value, current, voltage, power consumption, classification current and determined class
SNTP	Supports RFC 2030 Simple Network Time Protocol
SMTP	Supports RFC2821 Simple Mail Transfer protocol (option)
System log	System Log record up to 1000 entries.
Power monitor	Support power supply monitoring function for AC power, DC power, fan status 3 types of power supply can be installed with POE switch and POE-UPWM.
Power testing	Support test function to testing power supply.

Part Number	Description
26P000700	24x10/100TX (Managed
26P000701	1 DC 48V/400W output with UPS power supply

DragonLine Device Server

1xRS232/422/485 to 2x10/100TX



LAN	Ethernet: 2 10/100Mbps, RJ-45 (Redundant mode, Switch mode) Protection: Built-in 1.5 KV magnetic isolation
Serial	No. of ports: 1 RS-232/ 422/ 485 port, male DB-9, S/W selectable RS-232 Signals: TxD, RxD, RTS, CTS, DTR, DSR, DCD, GND Serial Line Protection: 15 KV ESD for all signals
DIP Switch	4 modes available for RS-232, RS-422, RS-485 two-wire, RS-485 four-wire
Beeper	Beeper for event warning or unit positioning
Serial Communication Parameters	Parity: None, Even, Odd, Space, Mark Data bits: 5, 6, 7, 8 Stop bits: 1, 1.5, 2 Flow control: RTS/CTS, XON/XOFF Speed: 110 bps to 460.8Kbps
LED	PWR 1 / Ready: 1) Red On: Power is on and booting up. Red Blinking: Indicates an IP conflict, or DHCP or BOOTP server did not respond properly. 2) Green On: Power is on and functioning normally. Green Blinking: Located by Administrator's Location function. PWR 2 / Ready: 1) Red On: Power is on and booting up. Red Blinking: Indicates an IP conflict, or DHCP or BOOTP server did not respond properly. 2) Green On: Power is on and functioning normally. Green Blinking: Located by Administrator's Location function. Eth1 Link / ACT: Orange Blinking: 10 Mbps Ethernet; Green Blinking: 100 Mbps Ethernet Eth2 Link / ACT: Orange Blinking: 10 Mbps Ethernet; Green Blinking: 100 Mbps Ethernet TX / RX: Serial port is receiving data(Orange); Serial port is transmitting data(Green).
Power Supply	Power Input 1: 12 to 48 VDC (3-pin Terminal Block) Power Input 2 (Redundant Power): 12 to 48 VDC (Φ2.0 DC Jack) Power Line protection: <ul style="list-style-type: none"> ▪ 1 KV Burst (EFT), EN61000-4-4 ▪ 0.5 KV Surge, EN61000-4-5
Power Consumption	3.55 Watt
Operating Humidity	5% to 95% (Non-condensing)
Operating Temperature	-10°C to 60°C
Storage Temperature	-40°C to 85°C
Mechanical Specifications	Material: Metal, IP-30
Case Dimension	72mm (W) x 32mm (D) x 100mm (H)
Regulatory Approval	RoHS
EMC	FCC Class A, CE Class A
Safety	UL, CUL

Protocols	ICMP, IP, TCP, UDP, DHCP, BootP, ARP / RARP, Telnet, RTelnet, DNS, SNMP MIB II, HTTP, SMTP, SNTP
Serial mode	Virtual Com / TCP Server / TCP Client / UDP / Serial Tunnel with advanced settings of <ul style="list-style-type: none"> ▪ TCP Alive Check Timeout ▪ Inactivity Timeout ▪ Delimiter for Data Packing ▪ Force TX Timeout for Data Packing
4 Hosts simultaneous connection	Virtual Com / TCP server / TCP Client (only raw data)
Security	HTTPS, SSH v2, SSL v3(data encryption)**
Event notification	Email / SNMP trap / Beeper SNMP Trap <ul style="list-style-type: none"> ▪ Cold/Warm Start ▪ DSR, DCD Changed ▪ IP Changed ▪ Authentication Fail SNMP Response <ul style="list-style-type: none"> ▪ System MIB, ▪ Interface MIB, ▪ ICMP, IP, TCP MIB ▪ UDP MIB ▪ RS-232 MIB
Utilities	X-Ware for Windows NT/2000/XP/2003/Vista <ul style="list-style-type: none"> ▪ Device discovery ▪ Auto IP report ▪ Device setting (run-time change, no rebooting) ▪ Access control list ▪ Group setting ▪ Device monitoring ▪ Serial port monitoring ▪ Log info ▪ Group Firmware update batch
Virtual COM/TTY Drivers (WDM mode, Config. in windows device manager)	Windows NT/2000/XP/2003, <ul style="list-style-type: none"> ▪ Unix Fixed TTY driver by request **, Linux real TTY driver by request **
Management	Web, X-Ware Utilities , SNMP , and Telnet
Serial API Function	Port Control, Input/Output Data, Port Status Inquiry

*: Future release

** : Optional

Part Number	Description
26700680	1xRS-232/422/485 port to 2x10/100TX

DragonLine 19"-Switch Managed

24x10/100TX or 24x100FX + 2x1000 Uplink (TX + FX)



Standard	IEEE802.3 10BASE-T / IEEE802.3u 100BASE-TX/100BASE-FX IEEE802.3z Gigabit SX/LX / IEEE802.3ab Gigabit 1000T / IEEE802.1q VLAN Tagging IEEE802.3x Flow Control and Back pressure / IEEE802.3ad Port trunk with LACP IEEE802.1d Spanning tree protocol / IEEE802.1w Rapid Spanning tree protocol IEEE802.1p Class of service / IEEE 802.1x User authentication
Connector	8-port 10/100TX module: RJ-45 8-port 100FX Multimode or Singlemode module: SC 2-port Gigabit SX/LX module: SC 2-port Gigabit 1000T module: RJ-45
Switch architecture	Store and forward switch architecture. Back-plane up to 8.8Gbps
MAC address	8K MAC address table with Auto learning function
Memory	3Mbits for packet buffer
Flash ROM	512Kbytes x 1
System memory	8Mbytes x 1
Expansion module	<ul style="list-style-type: none"> ▪ 8 10/100TX module with RJ-45 connector ▪ 8 100FX multi mode fiber module with SC connector ▪ 8 100FX singlemode fiber module with SC connector ▪ 2 Gigabit SX multi mode fiber module with SC connector ▪ 2 Gigabit LX singlemode fiber 10KM module with SC connector ▪ 2 Gigabit copper module with RJ-45 connector ▪ 1 Gigabit copper & 1 Gigabit SX module with RJ-45 connector and SC connector for multi mode 50~62.5/125µm fiber cable ▪ 1 Gigabit copper & 1 Gigabit LX 10KM module with RJ-45 connector and SC connector for singlemode 8~10/125µm fiber cable
LED	System Power 8 10/100TX module: Link/Activity (Green), Full duplex (Green) 8 100Base-FX module: Link (Green), Activity (Green Blinking) Gigabit Fiber: Link/ Activity Gigabit Copper: Link/Activity, Full duplex, 1000Mbps, 100Mbps
Power input	AC 100~240V, 50 /60Hz, 0.8A (maximum)
Power consumption	60 Watt (maximum)
Ventilation	2 x DC cooling fan with auto detect function
Operating temperature	0°C~45°C, 10%~95%RH
Storage temperature	-40°C~70°C, 95% RH
Dimension	440mm(W) x 280mm(D) x 44mm(H)
Weight	5.10Kg
EMI & safety	FCC Class A, CE
Safety	UL, cUL, CE/EN60950

Management	Telnet management, web management, Out band local console (RS-232)
RFC standard	RFC 1157 SNMP, RFC 1213 MIB II, RFC 1643 Ethernet like, RFC 1493 Bridge MIB, RFC 1757 RMON 1, RFC 1215 Trap, RFC 2674 VLAN MIB, private MIB
SNMP Trap	Cold start, link down, link up, authorization fail, fan fail trap. Trap station up to 3
Software Upgrade	TFTP and Console firmware upgradeable
Port Trunk	Support IEEE802.3ad with LACP function. Up to 7 trunk groups, trunk member up to 4 ports and include 2 uplink ports
Spanning Tree	IEEE802.1d spanning Tree
VLAN	Port based VLAN IEEE802.1Q Tag VLAN IEEE802.1v Protocol VLAN (IP, IPX,...) Static VLAN groups up to 256, Dynamic VLAN group up to 2048, VLAN ID from 0 to 4094
QOS policy	Supports 8 priority levels ID for two priority queue
Class of Service	Per port 2 queues, High/ low queue. Service rule: first come first service; all High before Low, WRR for High or low weight
Port-based Priority	Support 3 settings: "Disable, Low and High priority". When set to "Disable", the income packet will follow QoS policy; Otherwise, the packet will follow port priority setting to "High/Low" queue
IGMP	It supports IGMP V1 and V2 snooping. IGMP Snooping for Multi-Media application, IGMP group supports 256 groups
Port Security	MAC address filter for ingress and egress packet Static MAC address lock for source address
Port Mirror	Global system supports 3 mirroring types: "RX, TX and Both packet". The maximum of port mirror entries is up to 25
Bandwidth Control	Per port support Bandwidth control. Per level 100K
Stacking	The switch provide Stack Grouping feature and through master switch interface can manage and stack up to 8 units
802.1x Authentication	Support IEEE802.1x User-Authentication and can report to RADIUS server <ul style="list-style-type: none"> ➢ Reject ➢ Accept ➢ Authorize ➢ Disable
DHCP	DHCP client
Packet filter	Broadcast storm control

Part Number	Description
26000500	4-Slot Int. Chassis Switch
261000600	MIC 2x Mini-GBIC/SFP
261000650	MIC 2x10/100/1000TX
261000631	MIC 1x10/100/1000TX + 1x1000SX SC/MM/550m
261000632	MIC 1x10/100/1000TX + 1x1000LX SC/SM/10km
261000634	MIC 2x1000SX SC/MM/550m
261000635	MIC 2x1000LX SC/SM/10km
261000640	SFP SX LC Gigabit MM/550m/SFP for MIC
261000660	SFP LX LC Gigabit SM/10Km/SFP for MIC
26000520	MIC 8x100TX
26000600	MIC 8x10/100FX SC/MM/2km
26000620	MIC 8x100FX SC/SM/30km

DragonLine 19"-Gigabit Switch

24x10/100/1000TX or 24x1000SX (LX)



IEEE Standard	IEEE 802.3 10BASE-T / IEEE 802.3u 100BASE-TX / IEEE 802.3z Gigabit fiber IEEE 802.3ab 1000Base-T / IEEE 802.1ab LLDP IEEE 802.3ad Port trunk with LACP / IEEE 802.1w Rapid spanning tree IEEE 802.1p Class of service / IEEE 802.1q VLAN Tagging IEEE 802.1x User authentication / IEEE 802.3x Flow control and Back pressure
Switch Architecture	Back-plane (Switching Fabric):48Gbps
Connector	RS-232 console: 1 x DB-9 Female Gigabit copper module: 8 x RJ-45 MINI GBIC module: 8 x MINI GBIC (SFP) socket Gigabit Fiber module: 8 x SC for Gigabit SX or LX Gigabit copper + MINI GBIC module: 4 x RJ-45 + 4 x MINI GBIC
Packet Buffer	6Mbits
Mac Address	16K MAC address table
Flash ROM	8Mbytes
System memory	32Mbytes
Jumbo Frame	10 KB
Switch architecture	Store and forward
Protocol	CSMA/CD
LED	System Power Gigabit copper module: Link/Activity, Full duplex/collision Gigabit Fiber module: Link/Activity MINI GBIC module: Link/Activity Gigabit copper + MINI GBIC module: RJ-45 (Link/Activity, Full duplex/ collision), MINI GBIC (Link/Activity)
Power Supply	AC 100~240V 50/60Hz, Redundant Power: DC (12V~48V)
Power Consumption	35 Watt / 51 Watt
Operating Humidity	5% to 95% (Non-condensing)
Operating Temperature	0°C to 60°C
Storage Humidity	5% to 95% (Non-condensing)
Storage Temperature	-40°C to 70°C
Case Dimension	440mm(W) x 280mm(D) x 44mm(H)
Ventilation	2 FAN with fail detection
EMI	FCC Class A, CE
Safety	UL, cUL, CE/EN60950-1
Management	SNMP v1/v2c, Telnet, RMON1, CLI and Web management.
SNMP MIB	RFC 2863 Interface Group MIB / RFC 1213 MIBII, / RFC 1493 Bridge MIB RFC 2674 VLAN MIB / RFC 1643 Ethernet Like MIB / RFC 1215 Trap MIB RFC 1757 RMON MIB / Private MIB
SNMP Trap	Cold start/Warm start trap, Link down/Link up trap, Authentication fail trap,

Flow Control	IEEE802.3x Flow control: Flow control for 10/100/1000 full duplex, Back pressure for 10/100 half duplex
VLAN	Port based VLAN, up to 24 groups IEEE802.1Q Tag VLAN Static VLAN groups up to 4K entries and dynamic VLAN groups up to 2048, the VLAN ID can be assigned from 1 to 4094. GVRP
Port Trunk with LACP	IEEE802.3ad with LACP function. Up to 7 trunk groups with failover feature and the member up to 8 ports.
Spanning Tree	Support IEEE802.1w Rapid Spanning Tree
Class of Service	Per port 8 priority queues and support strict and WRR priority rule. Weight round ratio (WRR): 1:2:3:4:5:6:7:8 Weight round ratio (WRR):1:1:2:2:3:3:4:4 Weight round ratio (WRR):1:1:2:2:4:4:8:8
Quality of Service	Port based, Tag based, IPv4 Type of service, IPv4 Different service.
IGMP	IGMP snooping v1,v2 256 multicast groups and IGMP query
Port Security	128 entries of MAC address for static MAC and another 128 for MAC filter
Port Mirror	3 mirroring types: "RX, TX and Both packet".
Bandwidth Control	Per port support ingress rate limiting and egress rate shaping control. The rate limiting and rate shaping can be setting 64kbps by each level.(64kbps, 128kbps,256kbps...etc).
IP Security	IP address security to prevent unauthorized intruder.
Login Security	Support IEEE802.1x User-Authentication and can report to RADIUS server. <ul style="list-style-type: none"> ➢ Reject ➢ Accept ➢ Authorize ➢ Disable
Access Control List	The system provides control list on Source IP & Destination IP
DHCP	DHCP client and DHCP Server.
DNS	Provide DNS client feature and support Primary and Secondary DNS server.
System log	1000 records (Maximum) Provide remote storage ability and also can view the log by Web/Telnet/SNMP interface.
SNTP	Support RFC 2030 SNTP client.
SMTP	System supports 5 mail accounts and 2 Mail servers for Primary and Secondary. The SMTP will auto send event message to supervisor whom is pre-defined in the SMTP system through the pre-defined mail server.
LLDP	Support IEEE 802.1ab Link Layer Discovery Protocol

Order Number	Description
261000500	Unmanaged 3 Slots Modular Gigabit Chassis Switch 19" 1U

Order Number	Description
261000501	Managed 3 Slots Modular Gigabit Chassis Switch 19" 1U

Order Number	Description
261000510	MIC 8x10/100/1000T
261000511	MIC 8x1000SX SC/MM/550m)
261000512	MIC 8x1000LX SC/SM/10km
261000513	MIC 8xMini-GBIC
261000514	MIC 4x10/100/1000T + 4 Mini-GBIC module

DragonLine 19"-Gigabit Switch Managed

24x10/100/1000TX + 4x1000 SFP Shared



IEEE Standard	IEEE802.3 10Base-T Ethernet / IEEE802.3u 100Base-TX / IEEE802.3ab 1000Base-T IEEE802.3z Gigabit fiber / IEEE802.3x Flow Control and Back Pressure IEEE802.3ad Port trunk with LACP / IEEE802.1x User Authentication (Radius IEEE802.1d Spanning Tree/ IEEE802.1w Rapid Spanning Tree / IEEE802.1Q VLAN Tag) IEEE802.1p Class of Service
Switch Architecture	Back-plane (Switching Fabric): 48Gbps Packet throughput ability (Full-Duplex): 71.42Mpps @64bytes
Transfer Rate	14,880pps for Ethernet port 148,800pps for Fast Ethernet port 1,488,000pps for Gigabit Fiber Ethernet port
Packet Buffer	500Kbytes
Jumbo packet	9600bytes
Mac Address	8K
Flash ROM	512Kbytes x 2
SRAM	128Kbytes
Connector	1000Base-T: 24xRJ-45 with auto MDI/MDI-X. Gigabit fiber: 4 x MINI-GBIC socket ; shared with last 4-port RJ-45
Protocol	CSMA/CD
LED	System Power (Green) Gigabit copper port: 100/1000Mbps (Green), Link/Activity (Green),. Mini GBIC: Link/Activity (Green).
Power Supply	AC100 ~240V, 50/60Hz, 1A(Max)
Power Consumption	17.9 Watt (open issue)
Operating Humidity	10% to 90% (Non-condensing)
Operating Temperature	0°C to 45°C
Storage Temperature	-40°C to 70°C
Case Dimension	440mm (W) x 161mm (D) x 44mm (H)
Fan Number	1
Installation	19 "EIA /TIA Rack design,
EMI	FCC Class A, CE
Safety	UL, cUL, CE/EN60950-1

Management	SNMP v1/ Web/Telnet/CLI Management
SNMP MIB	RFC1213 MIBII, RFC 1493 Bridge MIB,
VLAN	Port Based VLAN IEEE802.1Q Tag VLAN (256 entries)/ VLAN ID (VLAN ID can be assigned from 1 to 4094.)
Port Trunk with LACP	LACP Port Trunk: 8 Trunk groups/Maximum 12 trunk members
Spanning Tree	Support IEEE802.1d Spanning Tree and IEEE802.1w Rapid Spanning Tree
Quality of Service	The quality of service determined by port, Tag and IPv4 Type of service, IPv4 Different Service
Class of Service	Support IEEE802.1p class of service, per port provides 4 priority queues
Port Mirror	Support mirroring types: RX packet
IGMP	Support IGMP snooping v1,v2, 255 multicast groups
IP Security	Support 1 IP address that has permission to access the switch management and to prevent unauthorized intruder.
Login Security	Support IEEE802.1X Authentication/RADIUS
Storm Control	The traffic storm control prevents LAN ports from being disrupted by a broadcast, multicast, or unicast traffic storm on physical interfaces.
Bandwidth Control	The rate control supports all of packet type and the limit rates are 128K~3968Kbps
Flow Control	Support Flow Control for Full-duplex and Back Pressure for Half-duplex
SNMP Trap	Up to 1 Trap stations Cold start, Port link up, Port link down
DHCP	Provide DHCP Client functions

Part Number	Description
261000900	24x10/100/1000TX + 4x1000(SX/LX) SFP

DragonLine 19"-Gigabit Switch Unmanaged

48x10/100/1000TX + COMBI: 2x10/100/1000T + 2x1000SFP



Standard	IEEE802.3 10BASE-T IEEE802.3u 100BASE-TX IEEE802.3ab 1000Base-T IEEE802.3z Gigabit fiber IEEE802.3x Flow control and Back pressure
Connector	100Base-T: 48 x RJ-45 Gigabit copper: 2 x RJ-45 MINI GBIC: 2 x MINI GBIC socket
Switch architecture	Store and forward switch architecture. Back-plane up to 20Gbps
MAC address	8K MAC address table with auto learning function
Packet buffer	7Mbits for packet buffer
LED	System power (Green) 10/100TX Port: Link/Activity (Green), Collision (Yellow) Gigabit copper port: Link/Activity (Green), Speed (Yellow) MINI GBIC: Link/Activity (Green)
Power	AC 100~240V, 50/60Hz
Power consumption	25 Watt @ AC 110V
Ventilation	Fan: 1 pc
Operating environment	0~45°C, 5%~95%RH
Storage environment	-40°C~70C, 95% RH
Dimension	440mm(W) x 225mm(D) x 44mm(H)
EMI	FCC Class A, CE
Safety	UL, cUL, CE/EN60950

Part Number	Description
261000800	48x10/100TX + 4xGigabit Uplink

DragonLine VDSL Extender

Ethernet to VDSL2 Extender



IEEE Standard	IEEE802.3 / IEEE 802.3u
IUT Standard	G.993.1 (VDSL) / G.997.1 compatible
Performance	Full VDSL2 bandwidth up to: (Down Stream / Up Stream) - 200m -> 88 / 49Mbps - 400m -> 63 / 29Mbps - 600m -> 46 / 18Mbps - 800m -> 30 / 5.7Mbps - 1000m -> 22 / 5.3Mbps - 1500m -> 18 / 0.8Mbps - 2000m -> 9 / 0.5Mbps
Connector	10/100TX: RJ-45 x 1 VDSL: RJ-45 x 1 with female Phone Jack
DIP Switch	DIP 1: Master, Slave Switch DIP 2: Impulse noise Protection DIP 3: Rate Limit control DIP 4: General Protection
LED	Per unit: Power1(Green) Power2(Green) Power-Fail(Red) 10/100TX: LNK/ACT(Green) VDSL: LNK/ACT(Green)
Power Supply	AC 24V DC 12~48V, Redundant power with polarity reverse protect and removable terminal block
Relay Alarm	1A @ DC24V
Operating Humidity	5%~95% (Non-condensing)
Operating Temperature	-40°C~75°C
Storage Temperature	-40°C~85°C
Case Dimension	Metal case. IP-30, 30 x 140 x 95 mm
Installation	DIN Rail and Wall Mount Design
EMC	CE, FCC Class A EN61000-6-4../ EN61000-6-2 / EN61000-4-2 (ESD) / EN61000-4-3 (Radiated RFI) EN61000-4-4 (Burst) / EN61000-4-5 (Surge) / EN61000-4-6 (Induced RFI) EN61000-4-8 (Magnetic Field) / EN61000-4-11 (Voltage Dip) EN61000-3-2 (Harmonics Current) / EN61000-3-3 (Voltage Fluctuation & Flickers)
Safety	UL508, Class 1/ Division 2
Shock	IEC60068-2-27
Freefall	IEC60068-2-32
Vibration	IEC60068-2-6

Part Number	Description
26V000100E	Industrial Ethernet to VDSL2 Extender -40°C~75°C

Audio and Video

Audio-, Video-, Telephone-, E1- and E3-Fiber-Optic-Systems



System description

eks offers a wide range of fiber optic systems for transmitting audio, video and telephone signals.

The systems offer different services for transmitting audio-, video-, CC- and data (RS232-, RS422- and RS485-interfaces).

Telephone interfaces like ISDN or analog telephone as well as E1- and E3 are also available.

Besides the classic point-to-point transmission of the above mentioned data, there are multiplexers or systems for optical bus or ring structures.

Important performance features of the transfer with multimode or singlemode fiber optic are the electromagnetic ruggedness, the potential separation of transmitter and receiver, as well as ranges up to 100km between two fiber optic systems. LEDs and potential-free contacts (optional) of a fault detector relay are able to signal defective states.

ST and SC optical connection type is also available. All systems can communicate via two as well as one fiber with the help of the BIDI-technology.

Please inquire your requested type if it is not listed in the adjoining chart.

Overview

	Signals	Fiber	Number of Fibers	
Audio	2A / D / CC	Multimode Singlemode	1 x MM / 2 x MM 1 x SM / 2 x SM	
Video	V	Multimode Singlemode	1 x MM 1 x SM	
	V / D	Multimode Singlemode	2 x MM 2 x SM	
	V / CC	Multimode Singlemode	2 x MM 2 x SM	
	V / D / CC	Multimode Singlemode	1 x MM / 2 x MM 1 x SM / 2 x SM	
	V / 2A / 2D / 2CC	Multimode Singlemode	1 x MM 1 x SM	
	4xV	Multimode Singlemode	1 x MM 1 x SM	
	4xV / D	Multimode Singlemode	1 x MM 1 x SM	
	4V / 2A / 5D / 2CC	Multimode Singlemode	1 x MM 1 x SM	
	8V	Multimode Singlemode	1 x MM 1 x SM	
	8V / 2A / 4D / 2CC	Multimode Singlemode	1 x MM 1 x SM	
16-128 V	Singlemode	1 x SM		
16-128 V / 2A / 4D / 2CC	Singlemode	1 x SM		
Telephone, E1, E3	Analog	Singlemode	1 x SM WDM	
	ISDN 1xSo	Multimode Singlemode	2 x MM 2 x SM	
	ISDN 4xSo	Multimode Singlemode	2 x MM 2 x SM	
	E1	Multimode Singlemode	2 x MM 2 x SM	
	E3	Multimode Singlemode	2 x MM 2 x SM	

FIMP

Industrial Compact Splice Box



System description

With 115mm x 61mm x 113mm, our industrial splice box is by far smaller than comparable 19" solutions.

Its inner values are really convincing as well so that the installation is quite simple and done very fast. FIMP is ready for splicing and contains splice tray, couplings, pig-tails and cable gland. Regarding different couplings, you can choose from SMA, ST, SC, LC, FC-PC, SC-RJ, E-2000 and E-2000 COMPACT. The front panel and the splice cassette can be removed for splicing and since the cassette is magnetic, it can easily be fixed onto a splice unit. The cassette has got a hole for splice units with a bolt.

The powder coated stainless steel housing is also magnetic so that the splice box can easily be affixed to another housing or to a switch cabinet in case of no different tray. Furthermore, FIMP has got a clip for DIN rail mounting (35mm) and a kit for wall fastening. Thus, there are space-saving and flexible solutions for mounting our FIMP. Please note the following advantages:

- The connecting point of the fiber optic cable can be set nearby the fiber optic systems, e.g. the switch board cabinet.
- The fiber optic cable is mechanically disconnected from the active fiber optic system.
- Separation of different fiber optic cables, e.g. indoor- or outdoor cable, as well as different connectors enables a clear and structured cabling.
- FIMP can be mounted directly on 35mm DIN-Rails next to the terminals in the switchboard cabinet, nearby the cable entry point.
- Laying unflexible fiber optic cables in small or over-crowded cable conduits is avoided.

The systems are built up modular. Customizing is possible by different assemblies, colors of the housing or logos.

Please inquire your requested type if it is not listed in the adjoining chart.



FIMP19 offers you the possibility to have up to three FIMP splice trays in a 19" 2HE rack. Additionally, fiber optic cables with MPO can be adapted by using FIMPO.

Ordering Information

Type MM	6xST Duplex 62MM	6xSC Duplex 62MM	3xLC Quattro 62MM	6xE2000 Duplex 62MM	6xST Duplex 50MM	6xSC Duplex 50MM	3xLC Quattro 50MM	6xE2000 Duplex 50MM	
Order-no. 0 6000	24196-00	24396-00	24493-00	24596-00	12196-00	12396-00	12493-00	12596-00	

Type SM	6xST Duplex	6xSC Duplex	6xSC 8° APC Duplex	3xLC Quattro	6xE2000 Duplex	6xE2000 8° APC Duplex			
Order-no. 0 6000	36196-00	36396-00	38396-00	36493-00	36596-00	38596-00			

Weight	450 g
Maße H x W x D	H: 115mm W: 61mm D: 100mm
Housing	Stainless steel, powder coated

Accessories	Order-No.	Description
	0600E90001	Cable gland M20
	0600E90002	Locknut M20
	0600E90003	Strain relief
	0600E90004	Dummy panel SC duplex
	0600E90005	Dummy panel Smarthole
	0600E90006	Dummy panel SC-RJ
	0600E90007	Splice holder
	0600E90008	Splice protection
	0600E90009	Cable tie
	0600E90010	Labelling strip
	0600E90011	Screws
	0600E90012	Clamping plate DIN rail
	0600E90013	Dual Mount Kit
	0600E90014	Tapping screw (metal)
	0600E90015	Protecting cap
	0600E90016	Mounting angle for protecting cap

Key for order numbers

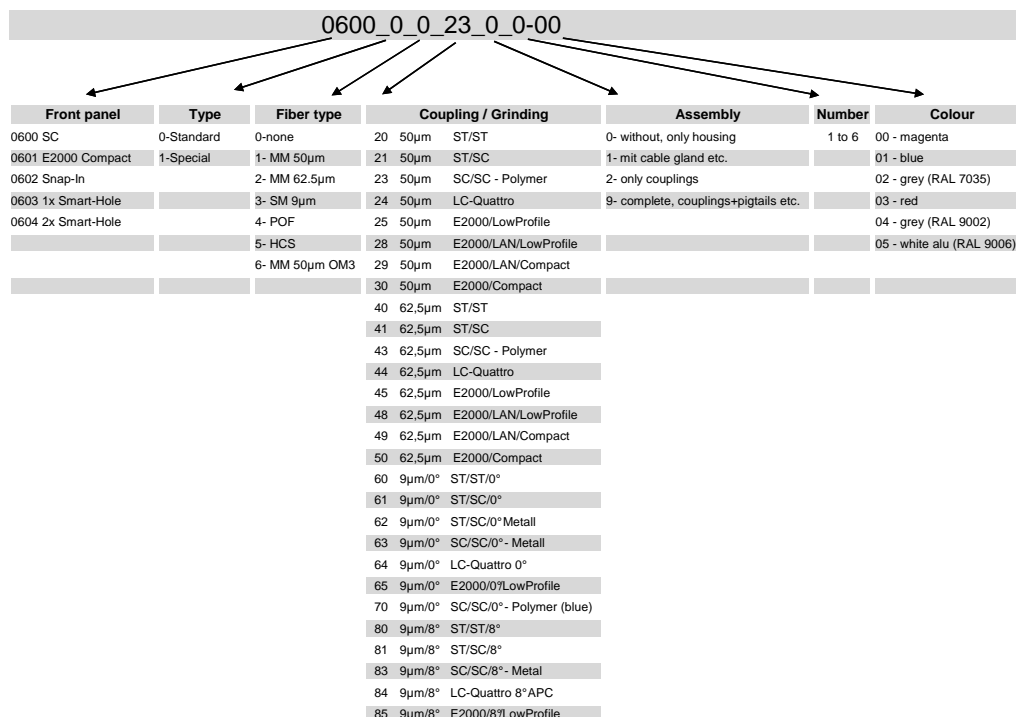

FIMP-XL

Industrial Compact Splice Box



System description

The inner values of the FIMP-XL are really convincing and the installation is quite simple and done very fast. FIMPXL is ready for splicing and it already contains splice tray, couplings, pigtails and cable gland. Regarding different couplings, you can choose from SMA, ST, SC, LC, FC-PC, SC-RJ, E-2000 and E-2000 COMPACT. The front panel and the splice cassette can be removed for splicing and since the cassette is magnetic, it can easily be fixed onto a splice unit. The cassette has got a hole for splice units with a bolt.

The powder coated stainless steel housing is also magnetic so that the splice box can easily be affixed to another housing or to a switch cabinet in case of no different tray. Furthermore, FIMPXL has got a clip for DIN rail mounting (35mm) and a kit for wall fastening. Thus, there are space-saving and flexible solutions for mounting our FIMP-XL. Please note the following advantages:

- The connecting point of the fiber optic cable can be set nearby the fiber optic systems, e.g. the switch board cabinet.
- The fiber optic cable is mechanically disconnected from the active fiber optic system.
- Separation of different fiber optic cables, e.g. indoor- or outdoor cable, as well as different connectors enables a clear and structured cabling.
- FIMP can be mounted directly on 35mm DIN-Rails next to the terminals in the switchboard cabinet, nearby the cable entry point.
- Laying unflexible fiber optic cables in small or overcrowded cable conduits is avoided.

Additionally fiber optic cables with MPO can be adapted by using FIMPO. And the optional cap protects your fiber and connectors.

The systems are built up modular. Customizing is possible by different assemblies, colors of the housing or logos.

Please inquire your requested type if it is not listed in the adjoining chart.

Ordering Information

Type MM	12xST Duplex 62MM	12xSC Duplex 62MM	6xLC Quattro 62MM	12xST Duplex 50MM	12xSC Duplex 50MM	6xLC Quattro 50MM			
Order-no. 0 6100	2406 24069-00	2436 24369-00	2443 24439-00	1216 12169-00	1236 12369-00	1246 00009-00			

Type SM	12xST Duplex SM	12xSC Duplex SM	12xSC 8° APC Duplex SM	12xLC Quattro SM					
Order-no. 0 6100	3606 36069-00	3616 3619-00	3836 38369-00	3646 36469-00					

Weight	860 g
Maße H x W x D	H: 138mm W: 72mm D: 128mm
Housing	Stainless steel, powder coated

Accessories	Order-No.	Description
	0600E90001	Cable gland M20
	0600E90002	Locknut M20
	0600E90003	Strain relief
	0600E90004	Dummy panel SC duplex
	0600E90005	Dummy panel Smarthole
	0600E90006	Dummy panel SC-RJ
	0600E90007	Splice holder
	0600E90008	Splice protection
	0600E90009	Cable tie
	0600E90010	Labelling strip
	0600E90011	Screws
	0600E90012	Clamping plate DIN rail
	0600E90013	Dual Mount Kit
	0600E90014	Tapping screw (metal)
	0600E90015	Protecting cap
	0600E90016	Mounting angle for protecting cap

Key for order numbers

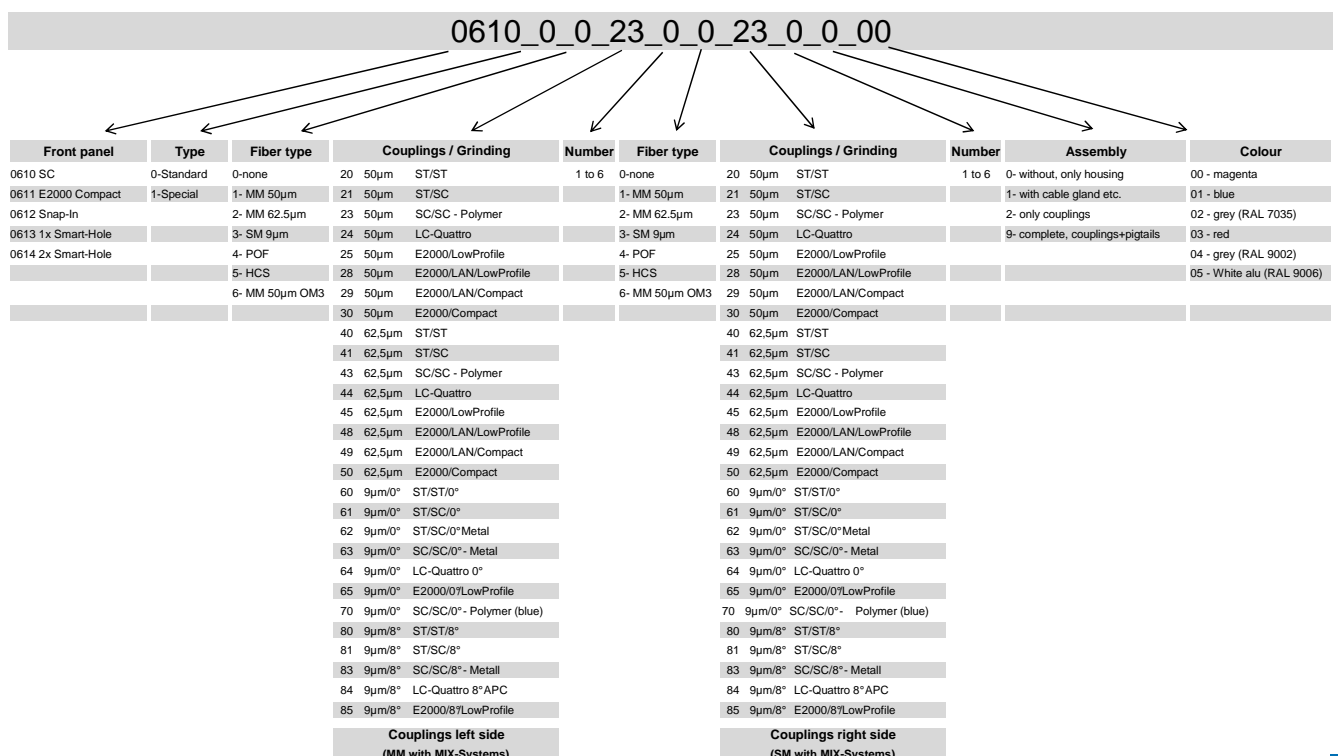

Acessory

Patchfields, Spliceboxes, Fiber Optic Cables



Passive Components

Our service is to support you with standard and customized fiber optic systems as well as with passive components, e.g.,

- Patchfields
- Spliceboxes
- Indoor-Cable (POF, HCS, Multimode, Singlemode, Hybrid-Cable)
- Outdoor-Cable (POF, HCS, Multimode, Singlemode, Hybrid-cable)
- Patchcords
- Assembly

Service

Development, Project Planning, Customizing



Development and project planning

Besides the well-established standard systems and services, eks also offers customized special solutions for industrial partners. Our well-trained construction team offers expert support from the early planning up to the final installation of the systems. In this context, eks uses its longtime expertise and the multifaceted applications of the fiber optic components, which are developed and produced at the eks headquarter since 1987.



Customizing

Together we create solutions. Customized applications consists of:

- creation of functional specification
- mechanical adjustments
- electronic development or modification
- documentation

and are delivered according to performance and time schedule.





eks Engel GmbH & Co. KG
Schützenstraße 2 · D-57482 Wenden · Germany
Tel.: +49(0)2762 9313-6 · Fax: +49(0)2762 9313-7906
<http://www.eks-engel.de> · e-mail: info@eks-engel.de